

# AC MHX

## HIPERFACE® - Motors



**EUROTHERM  
DRIVES**

**PRODUCT  
MANUAL**



**Further descriptions**, that relate to this document

UL: 05-01-5



Planetary Gearbox PG A - Product-manual

---

UL: 05-01-06



Planetary Gearbox PG AL - Product-manual

---

UL: 12-01



Plugs - Product description

---

UL: 12-02



Cables - Product description

---

© **EUROTHERM** Drives Limited.

All rights reserved. No portion of this description may be produced or processed in any form without the consent of the company.

Changes are subject to change without notice.

**EUROTHERM** has registered in part trademark protection and legal protection of designs.  
The handing over of the descriptions may not be construed as the transfer of any rights.

Made in Germany, 2002

# CONTENTS

	Page
<b>The most important thing first.....</b>	<b>4</b>
<b>1 General .....</b>	<b>5</b>
1.1 Description .....	5
1.2 Type to the model.....	6
1.2.1 Typical example .....	6
1.3 Possible options (Marking: g) .....	7
<b>2 General technical data .....</b>	<b>7</b>
<b>3 Technical data.....</b>	<b>8</b>
Model: AC <u>MHS</u> / AC <u>MHM</u> .....	8
Model: AC <u>MHS</u> / AC <u>MHM</u> .....	9
3.1 Torque/Speed Diagrams .....	10
3.1.1 Motor size 1.....	10
3.1.2 Motor size 2.....	11
3.1.3 Motor size 3.....	12
<b>4 Dimensions .....</b>	<b>13</b>
4.1 Standard design HIPERFACE® - Motor size <u>1...3</u> .....	13
4.1.1 Connections via connectors.....	13
<b>5 Connector assignment.....</b>	<b>14</b>
5.1 Connector .....	14
5.2 X50 - connector .....	16
5.3 HIPERFACE® connector .....	17
5.4 Cable designation .....	18
5.5 Plug designation .....	19
5.5.1 Mating plugs for motor- and brake connections .....	19
5.5.2 Mating plugs for HIPERFACE® .....	19
5.6 Cable designation .....	19
5.6.1 Motor - cable .....	19
5.6.2 HIPERFACE® - cable .....	19
<b>6 Technical data of the holding brake .....</b>	<b>20</b>
<b>7 Shaft loads .....</b>	<b>21</b>
7.1 <u>Radial</u> shaft load.....	21
7.1.1 Representation of the definition .....	21
7.1.2 Technical dates of the max. radial shaft load FR (N) .....	21
7.2 <u>Axial</u> shaft load .....	21
7.2.1 Representation of the definition .....	21
7.2.2 Technical dates of the max. axial shaft load FA (N).....	21
7.3 Use Ball bearing type .....	21
<b>8 Nominal power dependence of the Eurotherm AC servo motors concerning the installation hight.....</b>	<b>22</b>
8.1 Short description .....	22
<b>9 Certificates .....</b>	<b>23</b>
<b>10 Modification Record .....</b>	<b>24</b>



## The most important thing first

We thank you for the trust that you have shown in our product.

The operating instructions presented hereserves as an overview of the technical data and features.

Please read the operating instructions before putting the product to use.

If you have any questions, please contact your nearest Eurotherm representative.

Improper application of the product in connection with dangerous voltage, can lead to injuries.

In addition, damage can also occur to motors or other products.

Therefore please observe strictly our safety precautions.

Topic: Safety precautions

We assume that as an expert, you are familiar with the relevant safety regulations, especially in accordance with VDE 0100, VDE 0113, VDE 0160, EN 50178, the accident prevention regulations of the employers liability insurance company and the DIN regulations and that you can use and apply them. Also the CE - regulations are to be observed and guaranteed.

Depending on the kind of application, additional norms e.g. UL, DIN are to be observed.

If our products are employed in connection with components from other manufacturers, their operating instructions are also to be strictly observed.

# 1 General

## 1.1 Description

By using high-energy magnetic materials it is possible to design small diameter disk motors. For this reason and due to a carefully optimized technical construction of the rotor, the motors have a low inertia.

The stability of the magnetic material and the design of the magnetic field in the face of demagnetisation allow maximum currents of up to **3- 4 times the rated current**.

The high acceleration capacity of the low-inertia three-phase AC servo drives is the result of this.

Through the excitation of the permanent magnets, no heat losses due to current occur in the rotor.

With the three-phase AC-servomotors heat losses due to current occur only in the stator, which then can be directly carried off.

These favorable cooling conditions allow high-capacity windings.

Since all the current heat losses are carried off directly via the surface, the motors are designed at low cost with the enclosure type providing protection in accordance with **IP xx** and they are thus very resistant to liquids and dirt.

The **HIPERFACE**<sup>®</sup> is built into the B-side bearing bracket.

- **Singleturn:** (under preparation)

At applications of Hiperface –motors AC MHS only one revolution can be absolute resolved. The handling does not differ from Resolver generally.

- **Multiturn:**

Hiperface – motors AC MHM provide an absolute resolution of 4096 revolutions. The absolute position is available instantly (without search for reference)

Synchronous three-phase AC servo drives have a series of advantages over the DC drives:

- no electromechanical parts to wear out, therefore "maintenance-free".
- a low inertia of the rotor due to power density, therefore high acceleration capacity.
- no commutation limit curve, therefore high acceleration torques, also in higher speed ranges.
- no losses in the rotor of the motor, therefore favorable thermic qualities and a high degree of protection due to the closed construction.

Three-phase AC servomotors built in the way described, are specifically more efficient (higher rated torque) than DC servomotors and also have a small inertia. Therefore the size necessary for an application will, for this reason, be smaller with three-phase AC servos than with DC servos.

### **Please note:**

Motor will be shipped with mechanical adjusted Encoder (instead of Resolver).

It is NOT POSSIBLE to handle Motor and Encoder as separate components.



## General

### 1.2 Type to the model

Marking	Standard						optional	
	a	b	c	d	e	f	g	h
Model:	AC	<u>XXX</u>	XXXX	-X	/X	-X	XX	+ ...

Marking	Description
<b>a</b>	AC = three-phase
<b>b</b>	motor models: <u>MHS</u> = motor series Hiperface Singleturn (under preparation) <u>MHM</u> = motor series Hiperface Multiturn (4096)
<b>c</b>	<u>xxxx</u> = approx. rated torque in Ncm
<b>d</b>	-4 = 4000 rpm -X = further on request (designation does not apply with motor / gearbox systems)
<b>e</b>	/1..3 = motor size (designation does not apply with motor / gearbox systems)
<b>f</b>	-3 = 325 V DC intermediate circuit rated voltage -6 = 565 V DC intermediate circuit rated voltage
<b>g</b>	identification for options and custom features XX = see chapter 1.3
<b>h</b>	+ ... = with attached gear-box: (for short description for inserted gearbox models see gearbox documentation)

Note:

Up to marking "g" it is only necessary with options or custom features.

#### 1.2.1 Typical example

A typical example of an order corresponding to the model key would be:

Model:	AC <u>MHM</u> 0320-4/2-3
AC	= three phase
<u>MHM</u>	= Motor series <b>H</b> iperface <b>M</b> ultiturn
0320	= rated torque in Ncm
-4	= 4000 rpm
/2	= motor size
-3	= 325V DC

## General

### 1.3 Possible options (Marking: g)

Marking	Optionen			and Marking	Description
	BR	GW	IP 65		
GW		X			plain motor shaft
BR	X				holding brake, 24V DC
65			X		degree of protection IP 65
BG	X	X			holding brake / plain motor shaft
2P					2 <sup>nd</sup> featherkey way
6P			X	2P	2 <sup>nd</sup> featherkey way / degree of protection IP 65
G6		X	X		plain motor shaft / degree of protection IP 65
MS					mech. custom designs
SL					special finish
GK		X			plain motor shaft shortend
R6			X		rust-proof motor shaft
B6	X		X		holding brake / degree of protection IP 65
V6	X	X	X		holding brake / plain motor shaft / degree of protection IP 65
B4	X				flange B14
GZ		X			with centre hole / plain motor shaft
T6			X		for tropical climate / degree of protection IP 65

## 2 General technical data

Degree of protection: with mounted mating connectors and built-on motor	IP 54	●
	IP 65	○
Magnetic material:	NdFeB	●
Electrical connections:	rotatable 90° angular flange socket	●
Thermal protection of motor:	thermal detector PTC	●
Power: in accordance with DIN VDE 0530	installation site: 1000 m MSL.	●
	T = TU 40 °C measured with attached cooling surface	●
Voltage:	325 V	●
	565 V	●
	other windings are possible	○
Cooling:	self-cooling	●
Operating mode:	continuous operation S1	●
Bearings:	Ball bearings, service life approx. 15.000 h	●
Motor shaft: (standard)	with fitting key in accordance with DIN 6885	●
Rotational accuracy:	N, in accordance with DIN ISO 2373	●
Number of pole pairs:	3	●
Insulation class:	F (VDE 0530), 155 °C heating 100 °K	●
Varnish:(standard)	black (similar RAL 9005)	●
Feedbacksystem	HIPERFACE®	●

- standard design
- optional



### 3 Technical data

**Model: AC MHS / AC MHM**

AC-Servo motor Model:	size	Technical data				Static torque	Static current	max. Static torque	Moment of inertia included HIPERFACE
		Nominal power	Rated torque	Rated current with 325V DC   565V DC					
		PN (KW)	MN (Nm)	IN325 (A)	IN565 (A)	M0 (Nm)	I0 (A)	Momax (Nm)	JM (kgcm <sup>2</sup> )
AC MH.0055-4/1-3	1	0,23	0,55	1,40	-	0,80	2,10	3,20	0,29
AC MH.0055-4/1-6		0,23	0,55	-	0,85	0,80	1,20	3,20	0,29
AC MH.0090-4/1-3		0,38	0,90	1,80	-	1,50	3,00	6,00	0,67
AC MH.0090-4/1-6		0,38	0,90	-	1,10	1,50	1,80	6,00	0,67
AC MH.0150-4/1-3		0,63	1,50	3,30	-	2,50	5,00	10,00	0,99
AC MH.0150-4/1-6		0,63	1,50	-	1,90	2,50	2,70	10,00	0,99
AC MH.0220-4/1-3		0,92	2,20	4,70	-	3,00	6,40	12,00	1,39
AC MH.0220-4/1-6		0,92	2,20	-	2,80	3,00	3,80	12,00	1,39
AC MH.0290-4/1-3		1,22	2,90	6,00	-	4,00	8,30	16,00	1,79
AC MH.0290-4/1-6		1,22	2,90	-	3,00	4,00	4,20	16,00	1,79
AC MH.0320-4/2-3	2	1,34	3,20	6,40	-	4,00	8,20	16,00	2,39
AC MH.0320-4/2-6		1,34	3,20	-	3,60	4,00	4,50	16,00	2,39
AC MH.0480-4/2-3		2,01	4,80	9,80	-	7,00	14,30	28,00	3,19
AC MH.0480-4/2-6		2,01	4,80	-	4,90	7,00	7,20	28,00	3,19
AC MH.0650-4/2-3		2,72	6,50	13,20	-	9,00	18,30	36,00	3,59
AC MH.0650-4/2-6		2,72	6,50	-	6,60	9,00	9,20	36,00	3,59
AC MH.0830-4/2-6		3,48	8,30	-	9,30	11,00	12,30	44,00	-
AC MH.0960-4/3-6	3	4,02	9,60	-	11,00	16,00	18,40	64,00	5,25
AC MH.1200-4/3-6		5,03	12,00	-	16,00	21,00	28,00	84,00	6,65
AC MH.2000-4/3-6		8,37	20,00	-	19,30	34,00	33,00	136,00	11,15

Data at rated speed of 4000 rpm

## Technical data

Model: AC MHS / AC MHM

AC-Servo motor Model:	size	Mass	Motor resistance	Motor inductance	Thermal time constant		Torque constant	e.m.f constant eff.
					with IN	with Imax		
		m (kg)	Rph/ph (Ω)	Lph/ph (mH)	TthN (min)	Tthmax (s)	KT (Nm/A)	KE (V/1000 min-1)
AC MH.0055-4/1-3	1	2,00	6,20	9,80	20	51	0,39	25
AC MH.0055-4/1-6		2,00	18,40	39,00	20	51	0,66	40
AC MH.0090-4/1-3		2,90	3,10	10,00	20	51	0,50	30
AC MH.0090-4/1-6		2,90	7,70	24,00	20	51	0,83	50
AC MH.0150-4/1-3		3,70	1,57	6,00	23	59	0,50	30
AC MH.0150-4/1-6		3,70	5,25	15,00	23	59	0,94	55
AC MH.0220-4/1-3		4,30	1,10	4,20	26	66	0,50	30
AC MH.0220-4/1-6		4,30	2,80	11,00	26	66	0,83	50
AC MH.0290-4/1-3		5,30	0,80	3,20	30	77	0,48	30
AC MH.0290-4/1-6		5,30	2,17	12,80	30	77	0,97	60
AC MH.0320-4/2-3	2	6,00	1,00	4,20	19	49	0,49	30
AC MH.0320-4/2-6		6,00	3,00	12,70	19	49	0,98	55
AC MH.0480-4/2-3		7,60	0,43	2,60	29	74	0,49	30
AC MH.0480-4/2-6		7,60	1,90	10,50	29	74	0,98	60
AC MH.0650-4/2-3		8,50	0,47	1,90	38	97	0,49	30
AC MH.0650-4/2-6		8,50	1,30	7,60	38	97	0,98	60
AC MH.0830-4/2-6		15,70	0,77	4,55	50	128	0,89	54
AC MH.0960-4/3-6	3	19,50	0,57	6,30	36	92	0,87	58
AC MH.1200-4/3-6		22,00	0,30	3,25	52	133	0,75	48
AC MH.2000-4/3-6		30,00	0,29	3,60	88	225	1,04	65

Data at rated speed of 4000 rpm



## Technical data

### 3.1 Torque/Speed Diagrams

#### 3.1.1 Motor size 1

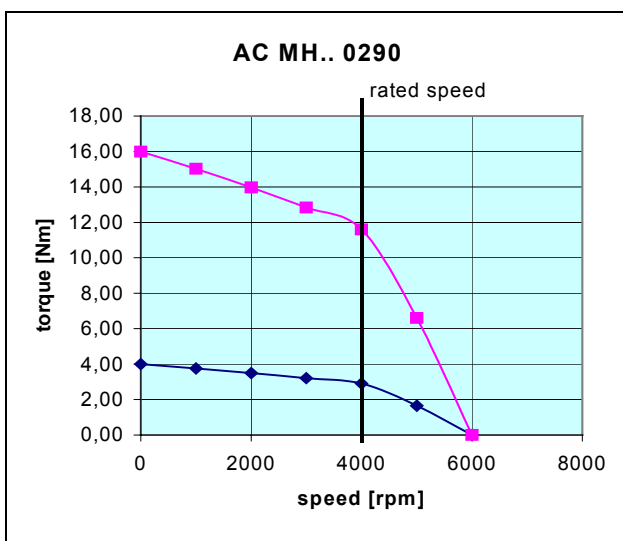
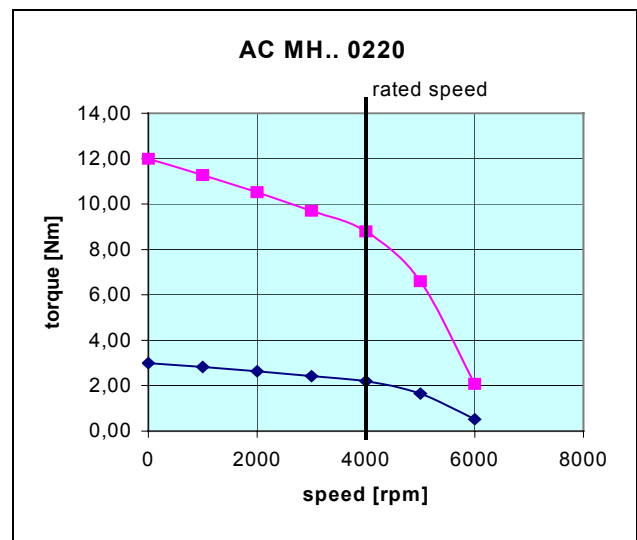
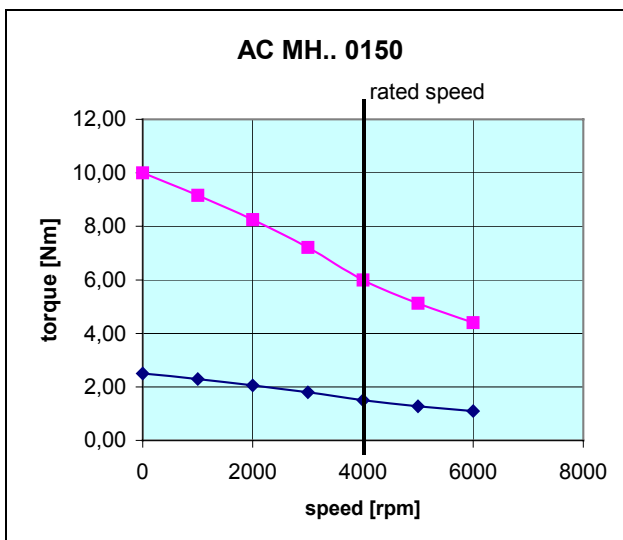
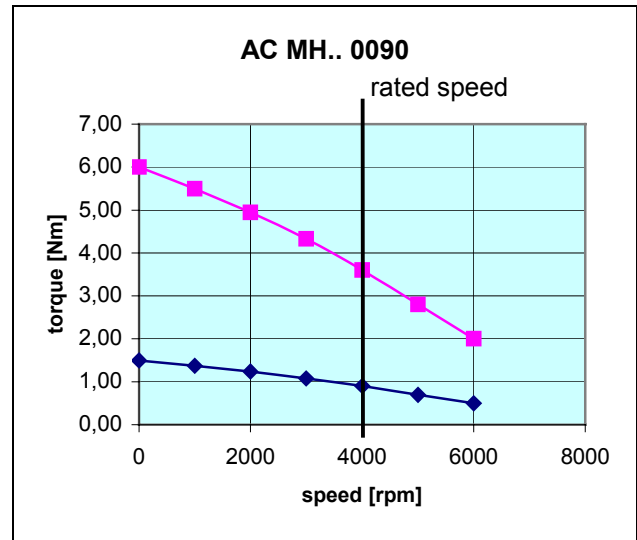
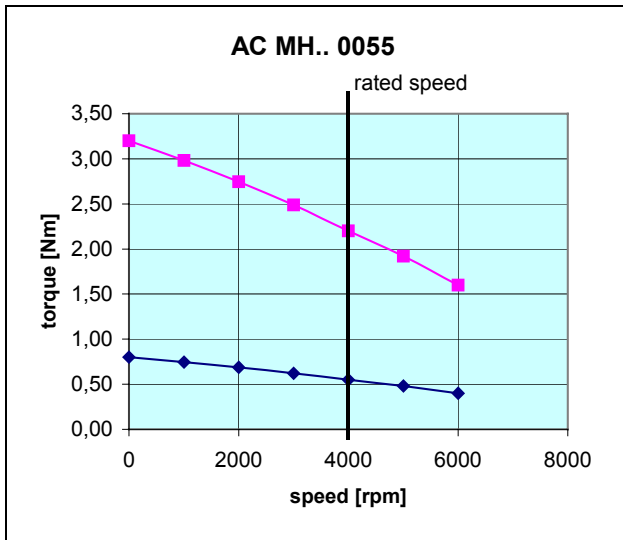

■ ■ ■ peak torque      ◆ ◆ ◆ continuous torque

# Technical data

## Torque/Speed Diagrams

### 3.1.2 Motor size 2

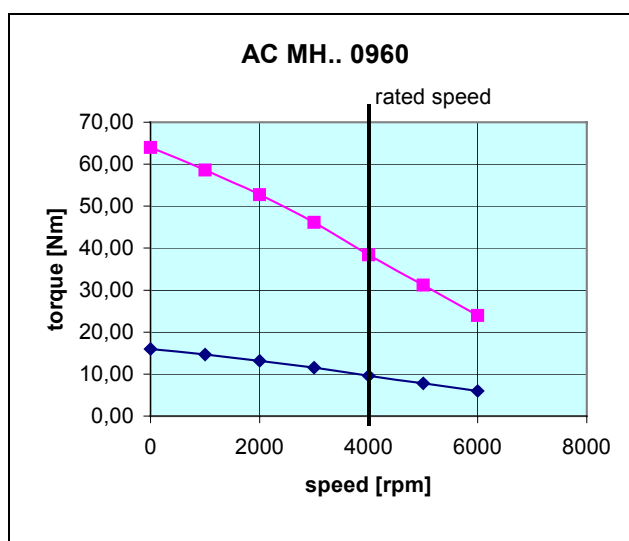
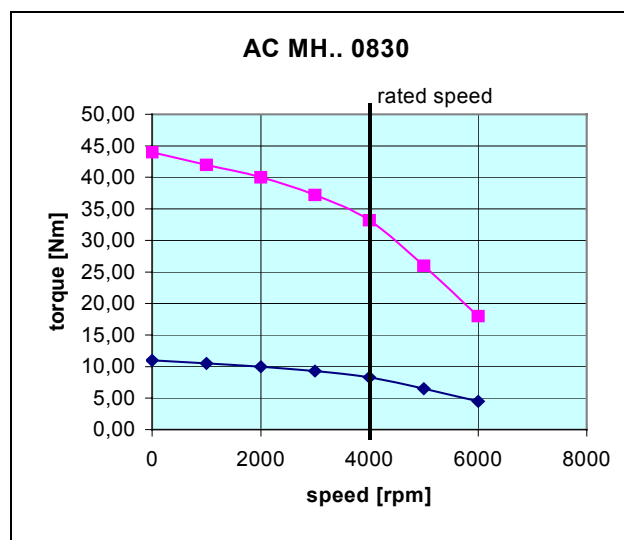
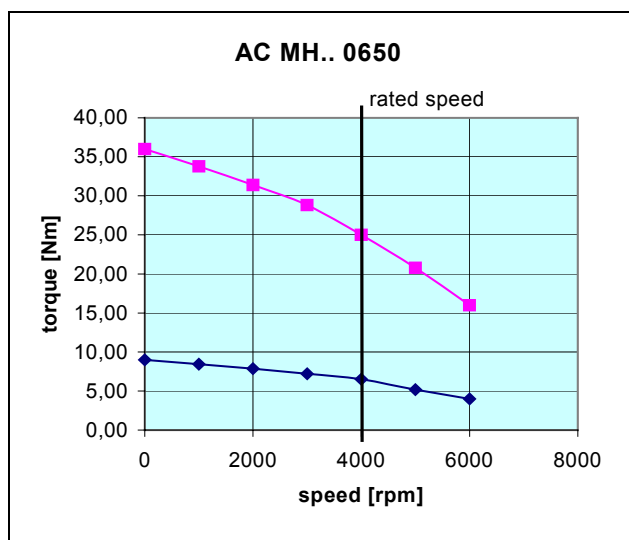
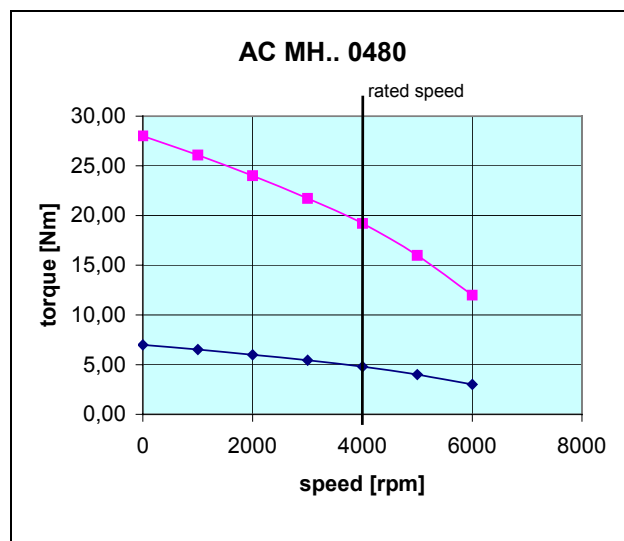
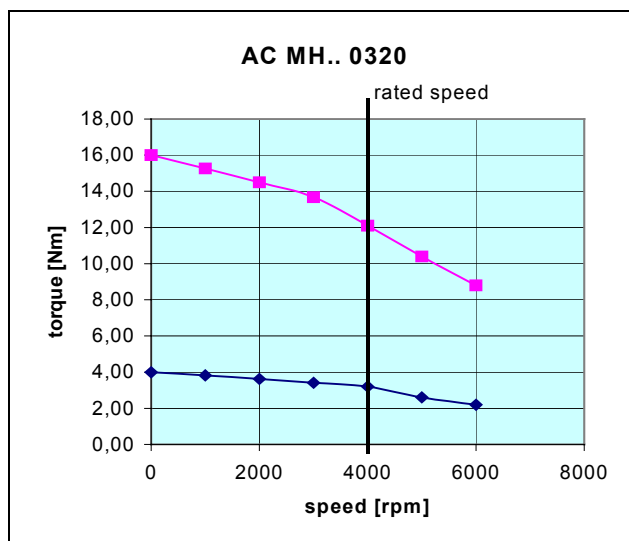

■ — ■ peak torque     
 ◆ — ◆ — ◆ continuous torque



## Technical data

### Torque/Speed Diagrams

#### 3.1.3 Motor size 3

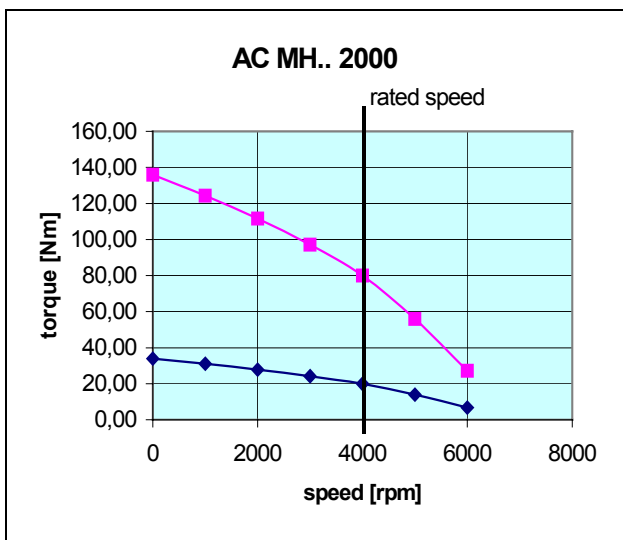
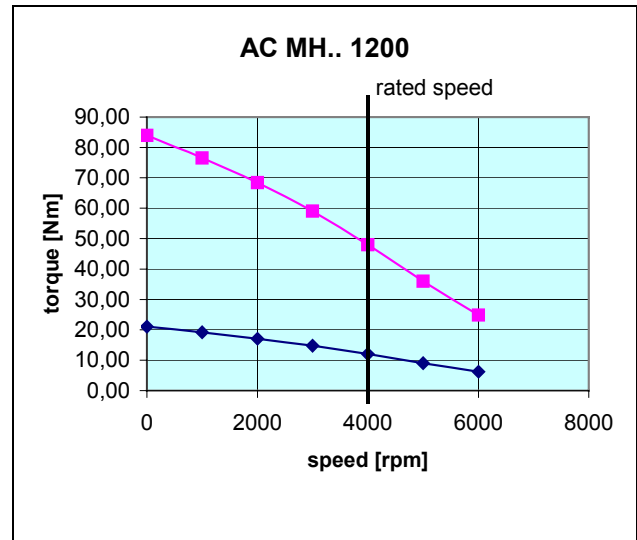
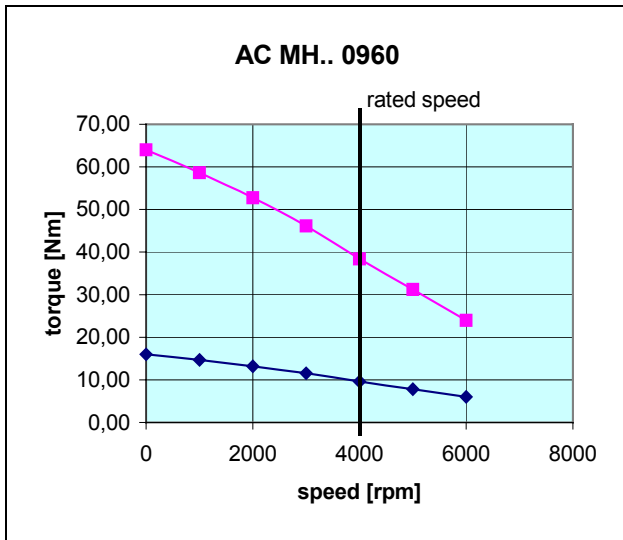

■ ■ ■ peak torque

◆ ◆ ◆ continuous torque

## 4 Dimensions

### 4.1 Standard design HIPERFACE® - Motor size 1...3

#### 4.1.1 Connections via connectors

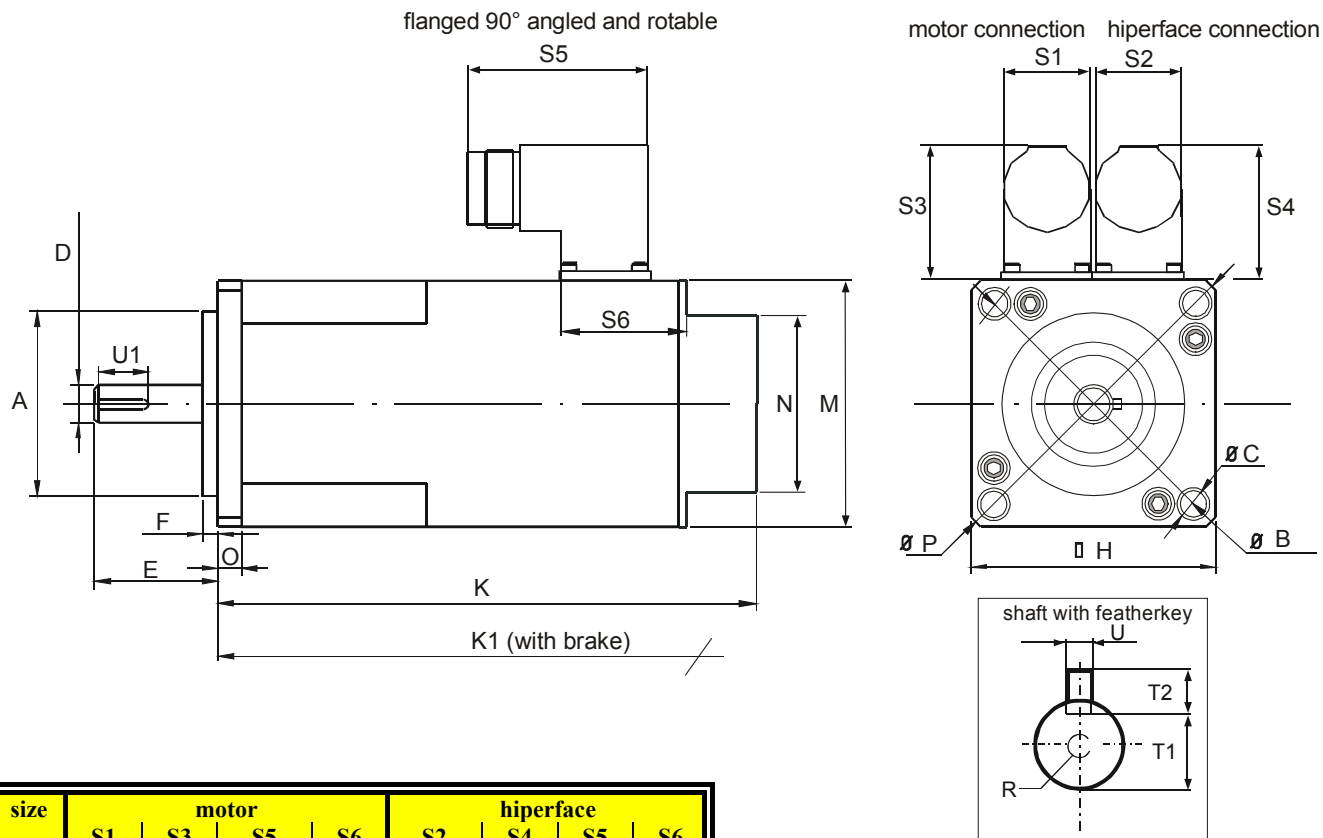

size	motor				hiperface			
	S1	S3	S5	S6	S2	S4	S5	S6
1...3	26,0	40,0	53,0	31,6	26,0	40,0	53,3	31,6

model	size	A (j6)	B	C	D (k6)	E	F	H	K	K1	M	N	O	P	R	T1	T2 (h9)	U (h9)	U1
AC MH..0055..	1	80	100	7	14	30	3	88	142	184	82	75	10	115	M4-12	11,1	5	5	20
AC MH..0090..		80	100	7	14	30	3	88	162	202	82	75	10	115	M4-12	11,1	5	5	20
AC MH..0150..		80	100	7	14	30	3	88	182	222	82	75	10	115	M4-12	11,1	5	5	20
AC MH..0220..		80	100	7	14	30	3	88	202	242	82	75	10	115	M4-12	11,1	5	5	20
AC MH..0290..		80	100	7	14	30	3	88	232	272	82	75	10	115	M4-12	11,1	5	5	20
AC MH..0320..	2	95	115	9	19	40	3	105	209	252	105	84	12	134	M6-15	15,5	6	6	30
AC MH..0480..		95	115	9	19	40	3	105	239	282	105	84	12	134	M6-15	15,5	6	6	30
AC MH..0650..		95	115	9	19	40	3	105	259	302	105	84	12	134	M6-15	15,5	6	6	30
AC MH..0830.. <sup>1)</sup>		95	115	9	19	40	3	105	309	352	105	84	12	115	M6-15	15,5	6	6	30
AC MH..0960..	3	130	165	11	24	50	3,5	145	284	327	145	117	12	188	M8-25	19,9	8	8	40
AC MH..1200..		130	165	11	24	50	3,5	145	324	367	145	117	12	188	M8-25	19,9	8	8	40
AC MH..2000..		130	165	11	24	50	3,5	145	444	487	145	117	12	188	M8-25	19,9	8	8	40

<sup>1)</sup> K1 with 6,2 Nm holding brake  
all specifications in "mm"



## 5 Connector assignment

### 5.1 Connector

#### Power connector

##### motor side

Eurotherm - motor size 0...2

Model: AC G, AC M2n  
**AC MHS / MHM**

##### regulator side

Eurotherm - Servo drives

Model: 631/635 and 637/637+  
**637+**  
in the compact enclosure

##### view solder / crimp connector - side

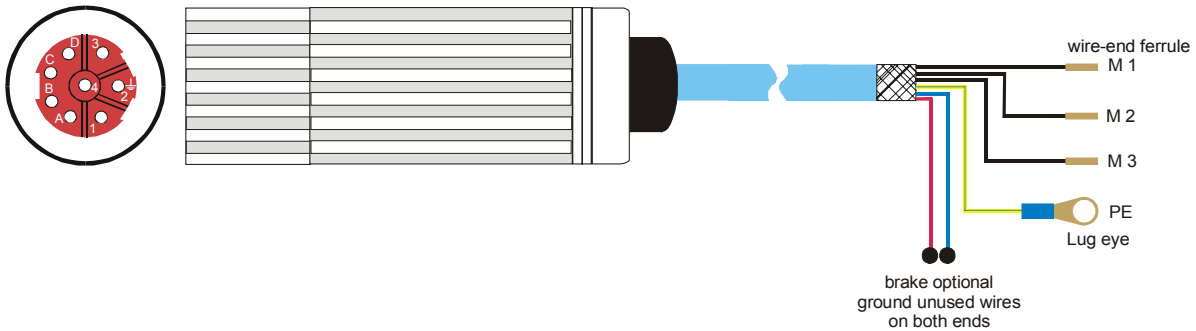

S MB GM2nRn BG 0/3-C+L ST.0100.3001		K MB BG 0/2-B KA.0003.6304		terminal strip	
PIN - Nr.		colour	function		PIN - Nr.
1		black 1	motor connection		M1
2	<sup>1)</sup>	yellow/green	ground connection		PE
3		black 2	motor connection		M2
4		black 3	motor connection		M3
A		red	brake +24V DC	<sup>2)</sup>	Connection
B		blue	brake 0V DC	<sup>2)</sup>	not on terminal
C		-	-		-
D		-	-		-
case	<sup>1)</sup>		screen		case

<sup>1)</sup> motor mating plug  
the screen is connected to the groundpin and also extensively to the case.

<sup>2)</sup> **Attention ! Security and insulation:**  
The brake must be insulated for secure division (PELV). Otherwise, the insulation class of the drive becomes reduced or the effort of an additional galvanic separation is required.

 EUROTHERM ANTRIEBE				Maßstab / scale:	
				Typ / model: KK MB GM2nRn 0/3.K	
				Bezeichnung / designation: Blue motor cable (compact enclosure) for Eurotherm standard motors and servo drives	
				Zeichnungsnummer / drawing No: Z-MK.6400.xxxx	
				Blatt sheet 1	
01	Motor-size	06.02.02	DI	Dateiname / File name: Z-MK.6401.xxxx_E.cdr	
Zust.	Änderung	Datum	Name	Ursprung	

# Connector

## Power connector

### motor side

Eurotherm - motor size 3

Model: AC M2n  
**AC MHS / MHM**

### regulator side

Eurotherm - Servo drives

Model: 631/635 and 637/637+  
**637+**  
in the compact enclosure

### view solder / crimp connector - side

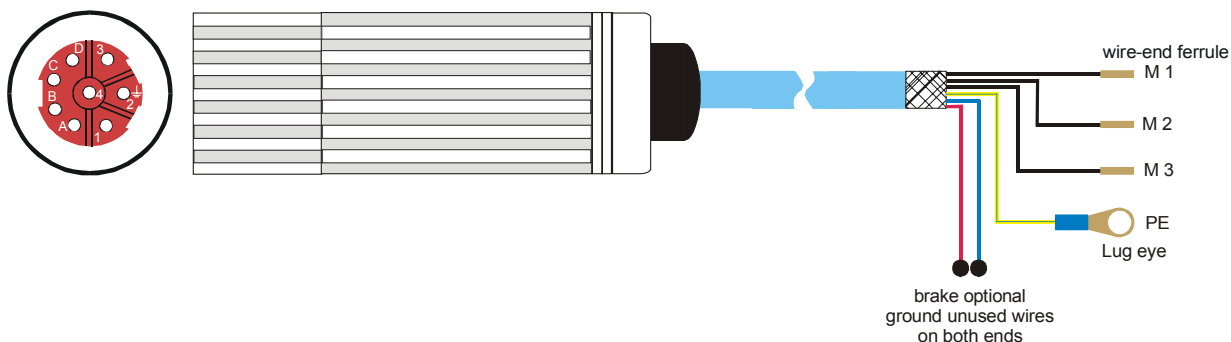

S MB GM2nRn BG 0/3-C+L ST.0100.3001		K MB BG 3-B KA.0003.6302		terminal strip	
PIN - Nr.		colour	function		PIN - Nr.
1		black 1	motor connection		M1
2	<sup>1)</sup>	yellow/green	ground connection		PE
3		black 2	motor connection		M2
4		black 3	motor connection		M3
A		red	brake +24V DC	<sup>2)</sup>	Connection
B		blue	brake 0V DC	<sup>2)</sup>	not on terminal
C		-	-		-
D		-	-		-
case	<sup>1)</sup>		screen		case

<sup>1)</sup> motor mating plug  
the screen is connected to  
the groundpin and also  
extensively to the case.

<sup>2)</sup> **Attention ! Security and insulation:**  
The brake must be insulated for secure division (PELV). Otherwise,  
the insulation class of the drive becomes reduced or the effort  
of an additional galvanic separation is required.

**Caution !** at X50 connector a terminal block must be employed

 EUROTHERM ANTRIEBE				Maßstab / scale:			
				Typ / model:		KK MB M2nRn 3	
Bear.		06.02.02	DL		Bezeichnung / designation: Blue motor cable for Eurotherm AC M2n size 3 motors and servo drives		
Gep.		14.02.02	EH				
Norm							
				Zeichnungsnummer / drawing No:			Blatt sheet 1
				Z-MK.6401.xxxx			
Zust	Änderung	Datum	Name	Ursprung	Dateiname / File name: Z-MK.6401.xxxx_E.cdr		

## 5.2 X50 - connector

### X50 - connector

#### motor side

Eurotherm - motor size 0...2

Model: AC M2n  
**AC MHS / MHM**

#### regulator side

Eurotherm - servo drives

Model: 635 and 637/637+  
**637+**  
in the Rack

#### view solder / crimp connector - side

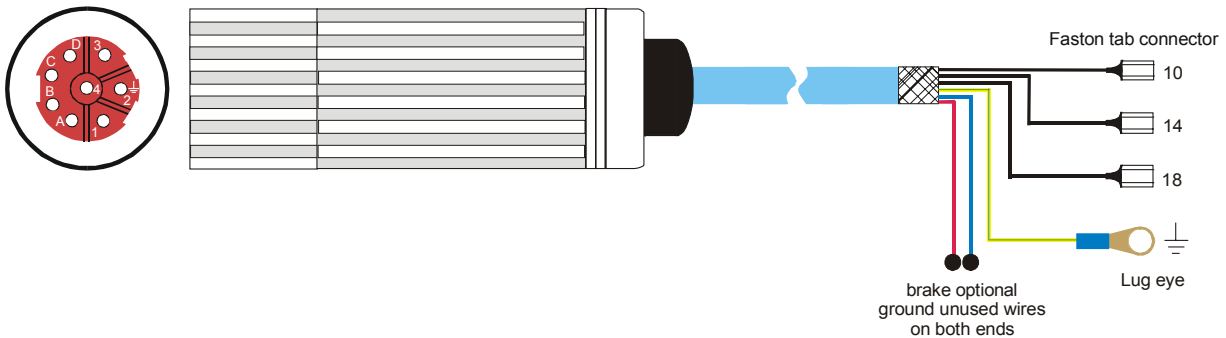

S MB GM2nRn BG 0/3-C+L ST.0100.3001		K MB BG 0/2-B KA.0003.6304		X50 connector strip		3)	
PIN - Nr.		colour		function		PIN - Nr.	
1		black 1		motor connection		10 ----- 12	
2		1) yellow/green		ground connection		ground	
3		black 2		motor connection		14 ----- 16	
4		black 3		motor connection		18 ----- 20	
A		red		brake +24V DC		2) -	
B		blue		brake 0V DC		2) -	
C		-		-		-	
D		-		-		-	
case		1)		screen		case	

1) motor mating plug the screen is connected to the groundpin and also extensively to the case.

2) **Attention ! Security and insulation:**  
The brake must be insulated for secure division (PELV). Otherwise, the insulation class of the drive becomes reduced or the effort of an additional galvanic separation is required.

3) not in the Scope of delivery

 <b>EUROTHERM ANTRIEBE</b>				Maßstab / scale:		Typ / model: KK MB GM2nRn 0/3.R	
				Bear.	10.05.01		
01 Motor-size 06.02.02 DL		Gep.	11.05.01	EH	Bezeichnung / designation: Blue motor cable (plugs/terminal strip) for Eurotherm standard motors and servo drives		
		Norm					
Zust. Änderung		Datum		Name		Ursprung	
Dateiname / File name: Z-MK.0400.xxxx_E.cdr		Zeichnungsnummer / drawing No: Z-MK.0400.xxxx		Blatt sheet 1			

### 5.3 HIPERFACE® connector

## Hiperfac connector

#### motorside

Eurotherm - motor size 1...3

Model: AC MHS / MHM

#### regulator side

Eurotherm - servo drive

Model: 637+

view solderside

keying

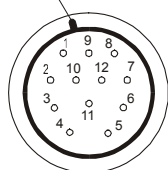

case - black



view solderside

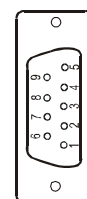
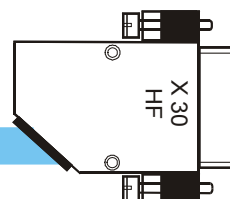

SIR ST.0200.0001	KIR-B KA.0003.6301		SUB - D 09 S/M ST.1002.2001
PIN - Nr.	colouer	function	PIN - Nr.
1	withe	sin +	4
2	brown	Ref sin	8
3	green	cos +	3
4	yellow	Ref cos	7
9	pink	Data +	9
10	gray	Data -	5
11	red	10 VDC	2
12	blue	GND	1
case		screen	case

 <b>EUROTHERM ANTRIEBE</b>						Maßstab / scale:	
						Typ / model: KK H MHx-xx.x/B	
		Bear.	22.04.02	DL	Bezeichnung / designation: Blue Hiperface cable for Eurotherm AC MHS / MHM motors and 637+ servo drives		
		Gep.	23.04.02	EH			
		Norm					
				Zeichnungsnummer / drawing No:			Blatt sheet 1
				Z-RK.8630.xxxx			
Zust	Änderung	Datum	Name	Ursprung	Dateiname / File name: Z-RK.8630.xxxx_E.cdr		



## 5.4 Cable designation

### Important rules when operating servo regulators and servomotors:

1. A radio interference suppression level cannot be maintained without an interference suppression filter at the line input. Moreover, line filter increase the immunity of the system to interference.
2. The cable between the power electronics and the motor must be shielded as YCY. A SY shield is not suitable. The shield support for the power cable (motor cable) must be on both ends. We recommend using Eurotherm motor cables K M BG 0/2-B-LC!
3. Metal parts in the switching cabinet must be connected with each other having large areas of contact and must carry high frequencies very well. Avoid anodized, yellow-passivized and painted surfaces which can have very high resistance values based on the frequency! Make sure that the metals lie close together in the chemical circuit voltage class! Use the good conductivity and the large surface of the galvanized mounting plate as earth potential!
4. Relays, contactors and solenoid valves build into the same circuit must be connected with spark-suppressing combinations or components limiting overvoltage, respectively. This applies also if these parts are not mounted in the same cabinet as the servo regulator.
5. The shield for the analog signal lines must be installed on one end and, if possible, in the switching cabinet. Ensure a connection which provides extensive contact and which is low-resistant! The shield for the digital signal lines must be installed on both ends, must have extensive contact and must be low resistance. An additional equalizer is to be laid parallel when there are potential differences. It is necessary to use plugs with metal enclosures with separable connections.
6. Avoid unnecessary extra loops on all connecting cables. All measures regarding filtering and shielding can be short circuited on them with high frequency. Connect unused litz wires in cables on both ends to the equipment ground conductor.
7. Unshielded cables of a circuit, the conductors going out and returning, should be twisted due to symmetrical interferences.
8. Separate physically "live" and "dead" wires even in the planning phase. Give special attention to the motor cables. The area of the common terminal strip-line input and motor output is especially endangered.
9. Relays, contactors and solenoid valves. The cables should be laid in the switching cabinet as close as possible to the ground; wires hanging freely in the air are preferred EMC victims as well as active and passive aeriels.
10. When operating with more than one line component in a common network, EMC problems are to be expected. From the start, the installation planner must integrate in his concept high frequency emitted interference as well as the electromagnetic susceptibility of the components to one another and take measures against it.
11. It is absolutely necessary to run cable shields completely up to the connectors. The connection of the cable shields to ground must be in the near field of the servo regulator (10 - 50 cm). Sensitive measuring leads should be removed as far as possible from this area; this applies also when they are shielded!
12. It is mandatory to run the motor cables in a separate cable channel and to lay flexible cable shielding also when these are shielded. This channel must be separated by at least 30 - 40 cm from the channel for the signal lines.

## 5.5 Plug designation

### 5.5.1 Mating plugs for motor- and brake connections

size	plug designation
1...3	S MB G M2nRn 0/3

### 5.5.2 Mating plugs for HIPERFACE®

size	plug designation
1...3	S HF - S

## 5.6 Cable designation

### 5.6.1 Motor - cable

size	cable designation	meaning
1...2	K MB R BG 0/2 – B	low cost
	K MB R BG 0/2 – B - LC	
3	K MB R BG 3 – B	

### 5.6.2 HIPERFACE® - cable

size	cable designation	meaning
1...3	K IR – B	low cost
	K IR – B - LC	



## 6 Technical data of the holding brake

optional

holding brake	motor size	holding torque	max. current	moment of inertia	weight
Typ:	BG	$M_{BrH}$	$I_{max}$	$J_{Br}$	$m_{Br}$
	(-)	(Nm)	(A)	(kg cm <sup>2</sup> )	(g)
BR M BG0	0	1,2	0,37	0,01	190
BR M BG1	1	3,2	0,42	0,03	445
BR M BG2	2	6,0	0,55	0,63	700
BR M BG3	3	12,0	0,75	2,10	1280

Supply voltage:  $U_S = 24 \text{ V DC}, \pm 10\% \text{ acc. VDE 0580}$

Holding brakes are integrated on A- side; therefore the motor length is changed, see dimension K1 !

**The inserted brake is not characterized for the general slowing-down the drives, but is merely a standstill and/or holding brake.**

Therefore, it must become guaranteed by the customer, that the drive stands, before that brake comes in. Should that brake not only become employed in the case of standing drives, so it's generally the wear and therefore the holding torque of the brake depending on:

- the speed of the drive with witch the brake will be switched
- the load moment of inertia on the drive
- environmental conditions as temperature, and so forth.
- the number of braking and so forth

## 7 Shaft loads

### 7.1 Radial shaft load

#### 7.1.1 Representation of the definition

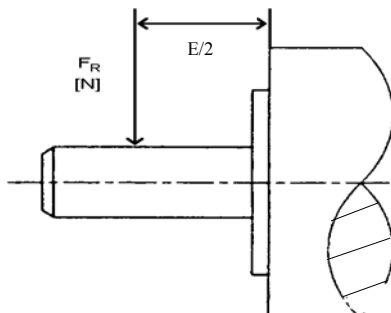

#### 7.1.2 Technical dates of the max. radial shaft load FR (N)

Motor size	rated speed	maximum radial shaft load
(-)	MN (1/min)	FR (N)
1	4000	250
2	4000	300
3	4000	570

### 7.2 Axial shaft load

#### 7.2.1 Representation of the definition

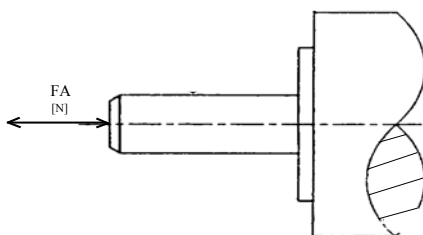

#### 7.2.2 Technical dates of the max. axial shaft load FA (N)

Motor size	rated speed	maximum radial shaft load
(-)	MN (1/min)	FA (N)
1	4000	90
2	4000	100
3	4000	200

The specifications refers to 20000 hours of operation !

### 7.3 Use Ball bearing type

Motor size	Ball bearing type	
	A-side	B-side
1	6003	6001
2	6004	6002
3	6005	6003



## 8 Nominal power dependence of the Eurotherm AC servo motors concerning the installation hight

### 8.1 Short description

When selecting an adequate motor the following is to be considered:

Workload (power), operating mode, starting, braking and by-passing processes, additional moment of inertia, moment course of the operating machine, speed control if necessary, net ratios, coolant temperature, installation hight etc.

The nominal power is the power which is mechanically available at the shaft, if the installation site is not situated above 1000 m MSL, the air temperature does not exceed 40° C, and the net ratios are normal.

With differing conditions concerning installation hight and air temperature, the permissible power must be corrected corresponding to the following picture.

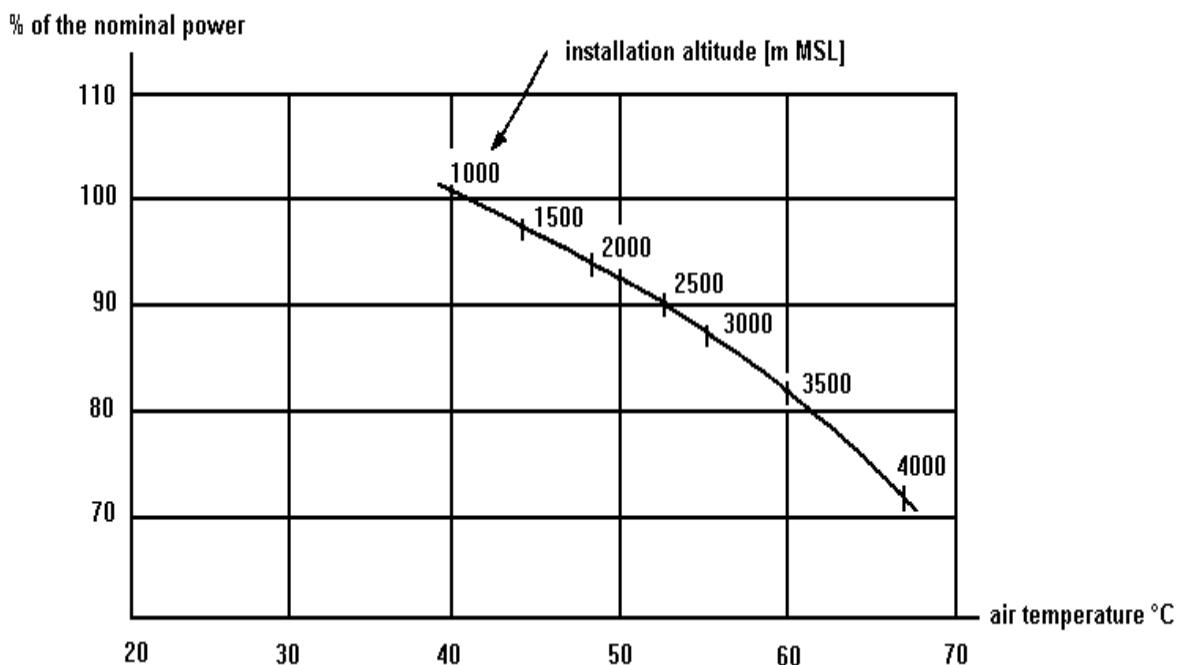

Check the air temperature and the installation hight separately. Should there be differing air temperatures and installation hights at the same time, the factors for the permissible power must be multiplied.

### Standard Specifications and Certifications

#### Manufacturer's Declaration

In accordance with the EC – MACHINERY DIRECTIVE 89/392/EEC  
Annex II B approximation of the regulation of the member states for machinery.

The following Products

**AC – Servo - motors of series AC M2n, AC MH.. and AC G**

in standard design are components to be incorporated into machinery and may not be operated alone. The complete machinery or installation using this equipment may only be put into service when the safety considerations of the Directive 89/3892/EEC are fully adhered to.

The above mentioned products are in accordance with the relevant clauses from the following standards.

**Basic directives:**

- EN 60034 / VDE 0530
- IEC 34 – 1,5,6,8,9,14 / IEC 72 / IEC 85
- VDE 0100, VDE 0110, VDE 0530-1
- EC – MASCHINERY DIRECTIVE 89/392/EEC
- EC – LOW VOLTAGE DIRECTIVE 73/23/EEC

CE – Lable

as standard on the name plate.

Issuer:

Eurotherm Antriebstechnik GmbH  
Im Sand 14  
76669 Bad Schönborn

Bad Schönborn, 26.04.2002

Legally binding signature



ppa. Erich Ehlen  
Plant Manager

This declaration does not include any assertion of properties. The references for safety and protection (operating instruction) are to observe in every case keep.



<b>AUSTRALIA</b> Eurotherm Pty Ltd.	Unit 10 40 Brookhollow Avenue Baulkham Hills New South Wales 2153	Tel.: +61 (2) 9634 8444 Fax: +61 (2) 96348555	<a href="http://www.eurotherm.com.au">http://www.eurotherm.com.au</a> <a href="mailto:eurotherm@eurotherm.com.au">eurotherm@eurotherm.com.au</a>
<b>AUSTRIA</b> Eurotherm GmbH	Geiereckstrasse 18/1 A1110 Vienna	Tel.: +43 (1) 798 7601 Fax: +43 (1) 798 7605	<a href="http://www.eurotherm.at">http://www.eurotherm.at</a> <a href="mailto:eurotherm@eurotherm.at">eurotherm@eurotherm.at</a>
<b>BELGIUM</b> Eurotherm BV	Rue du Val-Notre-Dame 384 B-4520 Moha	Tel.: +32 85274080 Fax: +32 85274081	<a href="mailto:sales@eurotherm-belgium.be">sales@eurotherm-belgium.be</a>
<b>CANADA</b> Eurotherm Drives	530 Seaman Street Unit 3 Stoney Creek Ontario L8E 3X7	Tel.: +1 (905) 664 8911 Fax: +1 (905) 6645869	<a href="mailto:andy.wright@eurothermdrives.com">andy.wright@eurothermdrives.com</a>
<b>DENMARK</b> Eurotherm Drives Danmark	Enghavevej 9D DK-7100 Vejle	Tel.: +45 (70) 201311 Fax: +45 (70) 201312	<a href="mailto:leif.tangaa@eurotherm.se">leif.tangaa@eurotherm.se</a>
<b>FRANCE</b> Eurotherm Vitesse Variable SA	15 Avenue de Norvège Villebon / Yvette 91953 Courtaboeuf Cedex Paris	Tel.: +33 1 (69) 185151 Fax: +33 1 (69) 185159	
<b>GERMANY</b> Eurotherm Antriebstechnik GmbH	Von-Humboldt-Strasse 10 64646 Heppenheim	Tel.: +49 (6252) 798200 Fax: +49 (6252) 798205	<a href="http://www.eurotherm.de">http://www.eurotherm.de</a> <a href="mailto:info@eurotherm.de">info@eurotherm.de</a>
<b>HONG KONG</b> Eurotherm Ltd.	Unit D 18/F Gee Chang Hong Centre 65 Wong Chuk Hang Road Aberdeen	Tel.: +852 2873 3826 Fax: +852 2870 0148	<a href="mailto:eurotherm@eurotherm.com.hk">eurotherm@eurotherm.com.hk</a>
<b>INDIA</b> Eurotherm India Ltd.	152 Developed Plots Estate Perungudi Chennai 600 096	Tel.: +91 (44) 496 1129 Fax: +91 (44) 496 1831	<a href="mailto:svs@euromds.rpgms.ems.vsnl.net.in">svs@euromds.rpgms.ems.vsnl.net.in</a>
<b>IRELAND</b> Eurotherm Ireland Ltd.	I.D.A. Industrial Estate Monread Road Naas Co. Kildare	Tel.: +353 (45) 879937 Fax: +353 (45) 875123	
<b>ITALY</b> Eurotherm Drives SPA	Via Gran Sasso 9 20030 Lentate Sul Seveso Milano	Tel.: +39 (0362) 557308 Fax: +39 (0362) 557312	<a href="http://www.eurothermdrives.it">http://www.eurothermdrives.it</a> <a href="mailto:info@eurothermdrives.it">info@eurothermdrives.it</a>
<b>JAPAN</b> Nemic-Lambda KK Eurotherm Division	Denpa Building 1-11-15 Higahi Gotanda Shinagawa-Ku Tokyo 141-0022	Tel.: +81 (3) 3447 6441 Fax: +81 (3) 3447 6442	<a href="http://www.eurotherm.com/japan.htm">http://www.eurotherm.com/japan.htm</a> <a href="mailto:II9K-IWM@asahi-net.or.jp">II9K-IWM@asahi-net.or.jp</a>
<b>KOREA</b> Eurotherm Korea Ltd.	3F J-Building 402-3 Poongnab-Dong Songpa-Ku Seoul 138 040	Tel.: +82 (2) 478 8507 Fax: +82 (2) 488 8508	
<b>NETHERLANDS</b> Eurotherm BV	Genielaan 4 2404CH Alpen aan den Rijn Holland	Tel.: +31 (172) 411 752 Fax: +31 (172) 417 260	<a href="http://www.eurotherm.nl">http://www.eurotherm.nl</a> <a href="mailto:sales@eurotherm.nl">sales@eurotherm.nl</a>
<b>NORWAY</b> Eurotherm Drives Norge	Postboks 650 1411 Koltbotn Oslo	Tel.: +47 (66) 992550 Fax: +47 (66) 803131	<a href="mailto:eurotherm@online.no">eurotherm@online.no</a>
<b>SPAIN</b> Eurotherm Espana SA	Calle La Granja 74 Pol. Ind. Alcobendas 28108 Madrid	Tel.: +34 (91) 6616001 Fax: +34 (91) 6619093	<a href="mailto:eurotherm@teleline.es">eurotherm@teleline.es</a>
<b>SWEDEN</b> Eurotherm Drivteknik AB	Box 9084 S-30013 Halmstad	Tel.: +46 (35) 177300 Fax: +46 (35) 108407	<a href="http://www.eurotherm.se">http://www.eurotherm.se</a> <a href="mailto:info.drives@eurotherm.se">info.drives@eurotherm.se</a>
<b>SWITZERLAND</b> Eurotherm Produkte (Schweiz) AG	Schwerzistrasse 20 CH 8807 Freienbach	Tel.: +41 (55) 4154400 Fax: +41 (55) 4154415	<a href="mailto:epsag@eurotherm.ch">epsag@eurotherm.ch</a>
<b>UK</b> Eurotherm Drives Ltd.	New Courtwick Lane Littlehampton West Sussex BN17 7RZ	Tel.: +44 (0) 1903 737000 Fax: +44 (0) 1903 737100	<a href="http://www.eurotherm.co.uk">http://www.eurotherm.co.uk</a> <a href="mailto:info@eurotherm.co.uk">info@eurotherm.co.uk</a>
<b>U.S.A.</b> Eurotherm Drives Inc.	9225 Forsyth Park Drive Charlotte North Carolina 28273	Tel.: +1 (704) 588 3246 Fax: +1 (704) 588 3249	<a href="http://www.eurothermdrives.com">http://www.eurothermdrives.com</a> <a href="mailto:russ.fulle@eurothermdrives.com">russ.fulle@eurothermdrives.com</a>

## Eurotherm Antriebstechnik GmbH

Im Sand 14 • D-76669 Bad Schönborn • Telefon 07253-940 40 • Fax 07253-940 499

E-Mail: [info@eurotherm.de](mailto:info@eurotherm.de) • Internet <http://www.eurotherm.de>