



# 890 Quickstart Manual

## 890SD (Standalone) Drive Frames E & F

HA471135U000 Issue 2 (ISO A4)  
HA471135U001 Issue 2 (American Quarto)

© Copyright 2007 Parker SSD Drives, a division of Parker Hannifin Ltd.

All rights strictly reserved. No part of this document may be stored in a retrieval system, or transmitted in any form or by any means to persons not employed by a Parker SSD Drives company without written permission from Parker SSD Drives, a division of Parker Hannifin Ltd. Although every effort has been taken to ensure the accuracy of this document it may be necessary, without notice, to make amendments or correct omissions. Parker SSD Drives cannot accept responsibility for damage, injury, or expenses resulting therefrom.

### WARRANTY

Parker SSD Drives warrants the goods against defects in design, materials and workmanship for the period of 12 months from the date of delivery on the terms detailed in Parker SSD Drives Standard Conditions of Sale IA058393C.

Parker SSD Drives reserves the right to change the content and product specification without notice.

# Contents

	<i>Page</i>
<b>Safety</b> .....	<b>3</b>
Hazards to Personnel	3
Application Risk	3
• Risk Assessment	4
• Accessibility	4
• Protective Insulation	4
• RCDs	4
<b>Introduction</b> .....	<b>5</b>
About this QuickStart	5
<b>Overview</b> .....	<b>6</b>
<b>Installation</b> .....	<b>7</b>
Mounting Dimensions	8
<b>890SD Frame E Power Connections</b> .....	<b>9</b>
<b>890SD Frame F Power Connections</b> .....	<b>10</b>
<b>890SD Control Connections</b> .....	<b>11</b>
<b>890SD Feedback Connections</b> .....	<b>12</b>
<b>Drive Start-up</b> .....	<b>13</b>
Before Applying Power :	13
<b>Drive Set-up</b> .....	<b>14</b>
Motor Data	14
Quick Setup Parameters	14
Autotune	15
Running in Local	16
Running in Remote	16
<b>Appendix A: Using the 6901 Keypad</b> .....	<b>17</b>
The Menu Structure	18
<b>Appendix B: Analog and Digital I/O</b> .....	<b>19</b>
890SD Control Terminals	20
<b>Appendix C: Electrical Ratings</b> .....	<b>21</b>

# Safety

**IMPORTANT** Please read this information **BEFORE** installing the equipment.

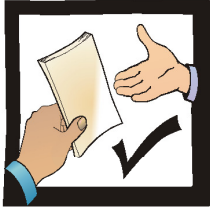

This manual is for anyone installing and operating this unit.



You must be technically competent to install and operate this unit.

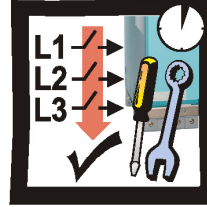

Before working on the unit, isolate the mains supply from terminals L1, L2 and L3 and wait 3 minutes.

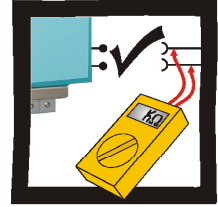

Disconnect the unit from circuits when doing high voltage resistance checks.

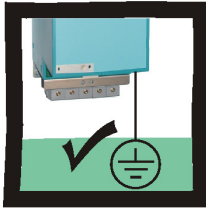

The unit must be **permanently earthed** due to the high earth leakage current.

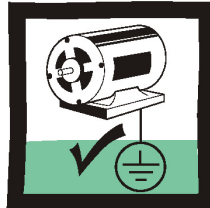

The drive motor must be connected to an appropriate safety earth.



Electrostatic discharge sensitive parts : observe static control precautions.



Copy existing 890 parameters to any replacement 890 unit

## Hazards to Personnel

This equipment can endanger life through rotating machinery and high voltages. Failure to observe the following will constitute an **ELECTRICAL SHOCK HAZARD**.

Metal parts may reach a temperature of 70 degrees Centigrade in operation.

Before working on the equipment, ensure isolation of the mains supply from terminals L1, L2 and L3. The equipment contains high value capacitors which discharge slowly after removal of the mains supply. Wait for at least 3 minutes for the dc link terminals (DC+ and DC-) to discharge to safe voltage levels (<50V). Measure the DC+ and DC- terminal voltage with a meter to confirm that the voltage is less than 50V.

Do not apply external voltage sources (mains supply or otherwise) to any of the braking terminals (DBR+, DBR-, DC+, INT or EXT).

## Application Risk

The specifications, processes and circuitry described herein are for guidance only and may need to be adapted to the user's specific application.

Parker SSD Drives does not guarantee the suitability of the equipment described in the Manual for individual applications.

---

## Risk Assessment

Under fault conditions, power loss or other operating conditions not intended, the equipment may not operate as specified. In particular:

- The motor speed may not be controlled
- The direction of rotation of the motor may not be controlled
- The motor may be energised

---

## Accessibility

All live power terminals are IP20 rated only, since the equipment is intended to be installed within a normally-closed cubicle or enclosure, which itself requires a tool to open.

---

## Protective Insulation

- All control and signal terminals are SELV, i.e. protected by double insulation. Ensure all wiring is rated for the highest system voltage.

**NOTE** *Thermal sensors contained within the motor must be single/basic insulated.*

- All exposed metalwork in the Drive is protected by basic insulation and bonding to a safety earth.

---

## RCDs

Not recommended for use with this product. Where their use is mandatory, use only Type B RCDs (EN61009).

---

## Caution

This is a product of the restricted sales distribution class according to IEC 61800-3. It is designated as “professional equipment” as defined in EN61000-3-2. Permission of the supply authority shall be obtained before connection to the low voltage supply.

---

# Introduction

The 890SD Standalone Drive is designed for speed control of standard ac 3-phase motors.

- Control it remotely using configurable analogue and digital inputs and outputs.
- Control it locally using the 6901 Keypad.
- Use the Design System Explorer Configuration Tool (DSE 890) to give access to parameters, diagnostic messages, trip settings and application programming.
- Fit Options to the unit to give serial communications and closed loop speed control.

**IMPORTANT:** *Motors used must be suitable for Inverter duty.*

## About this QuickStart

**This QuickStart will:**

- Familiarise you with the terminals and operation of the unit.
- Provide **\*basic** installation details and a quick set-up procedure.
- Show you how to Autotune the drive and start the motor.

*\* Because the 890 is a system product and we have no knowledge of your application, we detail the quickest way to power-up the drive using a simple earthing scheme with minimal control wiring. Refer to the full Engineering Reference Manual for items not covered in this QuickStart.*

**Provided with every 890 unit is a :**

- Quickstart
- Compact disk containing the Engineering Reference Manual and DSE Configuration Tool
- 890 Installation Kit and instruction leaflet
- 6901 Keypad
- Customer-ordered Options

**This QuickStart assumes that:**

- You are a qualified technician with experience of installing this type of equipment.
- You are familiar with the relevant standards and Local Electric Codes (which take precedence).
- You have read and understood the Safety information provided at the front of this QuickStart.
- You realise that this guide contains only basic information and that you may need to refer to the Engineering Reference Guide to complete your installation.

# Overview

## 890SD (Frame E illustrated)

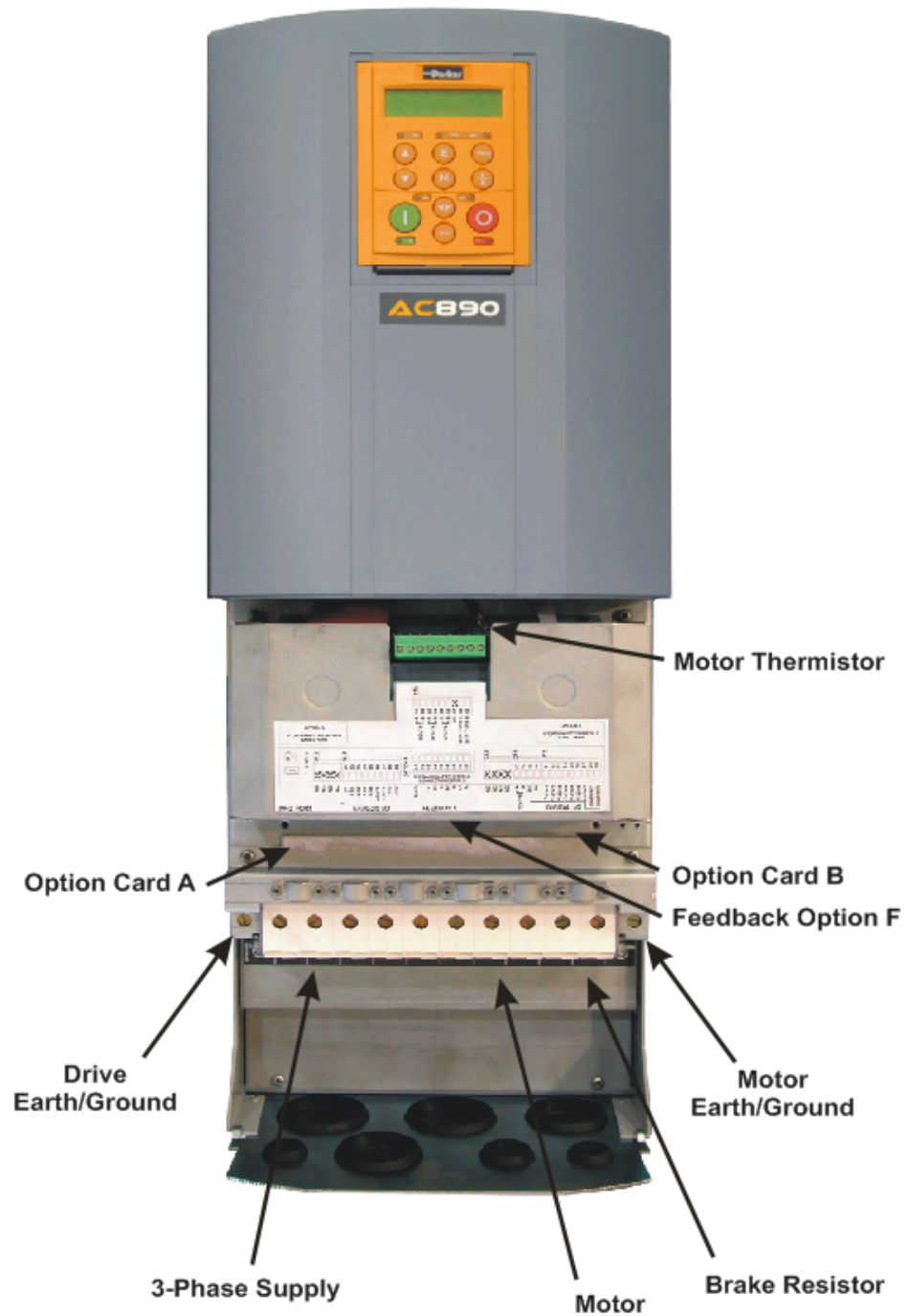

# Installation

A simplified installation is shown below. This installation is **not** EMC compliant. For European installations and countries with EMC legislation refer to the 890 Engineering Reference Manual, Appendix C.

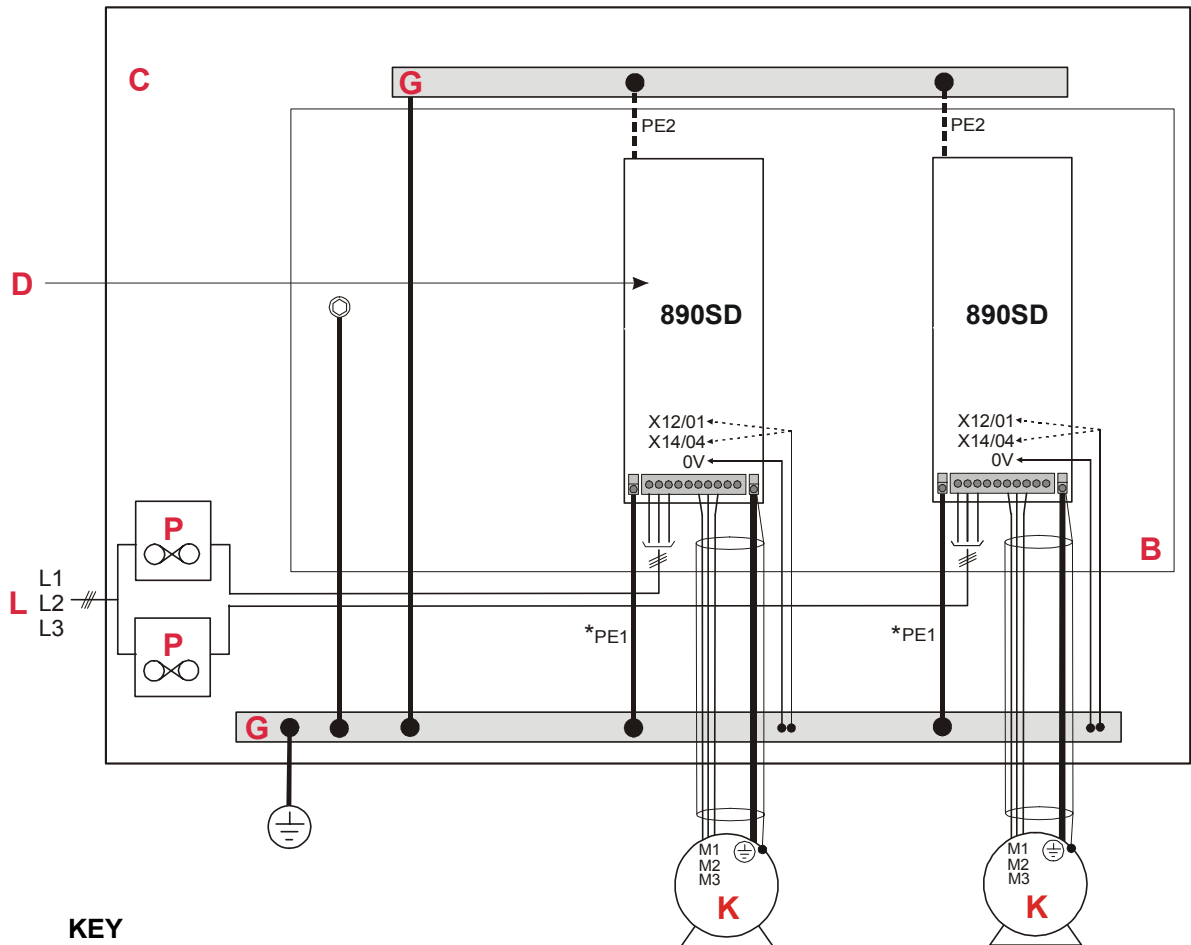

## KEY

- B** Back-plate
- C** Cubicle
- D** Control Wiring terminals
- G** Supply Protective Earth/Ground
- K** Motor (M1, M2, M3)
- L** 3Ø Power Supply Cable (L1, L2, L3)
- P** Fuse or circuit breaker

### \* Permanent Earthing

The unit must be **permanently earthed** according to EN 50178: For permanent earthing, one conductor, PE1, of >10mm<sup>2</sup> cross-section is required; or two individual incoming protective earth conductors, PE1 & PE2, of <10mm<sup>2</sup> cross-section. Each earth conductor must be suitable for the fault current according to EN 60204.

# Mounting Dimensions

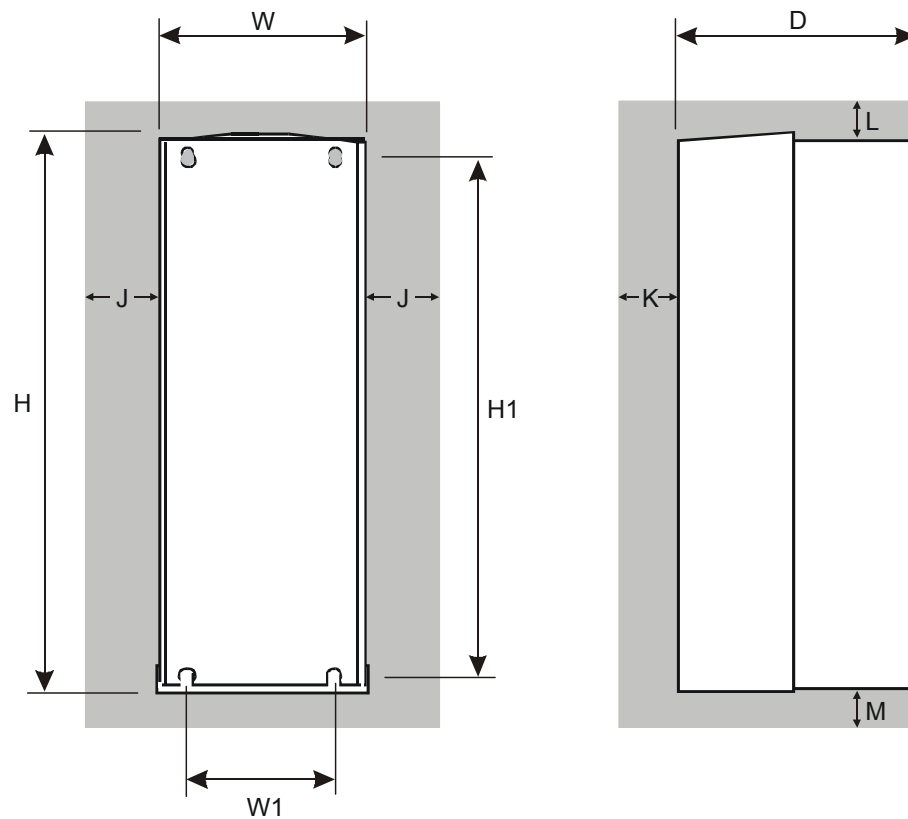

The units must be installed in a cubicle. Mount the drive using the keyholes and slots.

Models	Maximum Weight: kg/lbs	H	H1	W	W1	D	Air Clearance				Fixings
							J	K	L	M	
Frame E	32.5/72	668.6 (26.3)	630.0 (24.8)	257.0 (10.1)	150.0 (5.9)	312 (12.3)	0 (zero)	25 (1)	70 (2.8)	70 (2.8)	Use M6 fixings
Frame F	41/90.4	720.0 (28.3)	700.0 (27.6)	257.0 (10.1)	150.0 (5.9)	355.0 (14.0)	0 (zero)	25 (1)	70 (2.8)	70 (2.8)	Use M6 fixings
All dimensions are in millimetres (inches)											

## Ventilation

The drive gives off heat during normal operation. Mount it to allow free flow of air through the ventilation slots and heatsink. The mounting surface must be normally cool. Maintain the minimum air clearances. Clearances are additive when mounting two 890 units together. Ensure heat from adjacent equipment is not transmitted. Maintain the clearance requirements of other equipment.

## Environmental Conditions

Operating ambient temperature  
Enclosure rating  
Atmosphere

0°C to 45°C (32°F to 113°F)  
IP20 – UL(cUL) Open type  
Dust free, non flammable, non-corrosive, <85% humidity,  
non-condensing



# 890SD Frame E Power Connections

**5** Connect motor leads to M1/U, M2/V, M3/W.

Maximum wire sizes::

Frame E: 50mm<sup>2</sup>/1AWG (without crimp)  
70mm<sup>2</sup>/ 1/0AWG (with crimp)

- Connect the earth/ground wire from the terminal box of the motor directly to the earth/ground terminal.

Maximum wire sizes:

Frame E: 50mm<sup>2</sup>/1AWG (without crimp)  
70mm<sup>2</sup>/ 1/0AWG (with crimp)

- If not using shielded cable, run motor leads in an enclosed metal conduit bonded to the drive at one end and the motor at the other.

**7** Connect the 3-phase supply.

Maximum wire sizes:

Frame E: 50mm<sup>2</sup>/1AWG (without crimp)  
70mm<sup>2</sup>/ 1/0AWG (with crimp)

**8** Connect the brake resistor.

Maximum wire sizes:

Frame E: 50mm<sup>2</sup>/1AWG (without crimp)  
70mm<sup>2</sup>/ 1/0AWG (with crimp)

- An External Braking Resistor is optional. Connect it between DBR+ and DBR- for high inertial loads.

*DO NOT* apply external voltage sources (mains supply or otherwise) to the braking terminals.

We recommend using a thermal overload switch to protect the braking circuit.

**6** Connect the earth/ground wire to the earth/ground terminal.

Maximum wire sizes:

Frame E: 50mm<sup>2</sup>/1AWG (without crimp)  
70mm<sup>2</sup>/ 1/0AWG (with crimp)

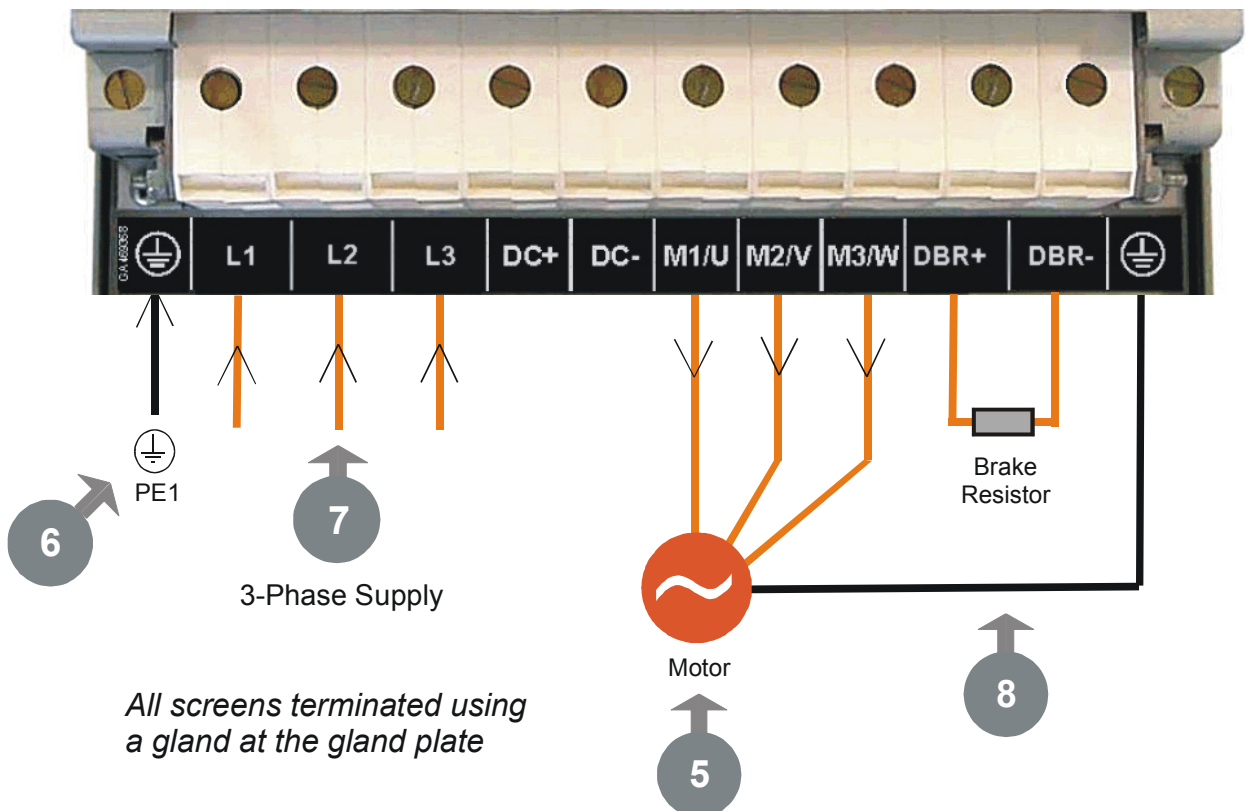

# 890SD Frame F Power Connections

- 5** Connect motor leads to M1/U, M2/V, M3/W.  
Maximum wire sizes::  
Frame F: 95mm<sup>2</sup>/ 4/0AWG (without crimp)  
95mm<sup>2</sup>/ 4/0AWG (with crimp)
- Connect the earth/ground wire from the terminal box of the motor directly to the earth/ground terminal.  
Maximum wire sizes:  
Frame F: 95mm<sup>2</sup>/ 4/0AWG (without crimp)  
95mm<sup>2</sup>/ 4/0AWG (with crimp)
  - If not using shielded cable, run motor leads in an enclosed metal conduit bonded to the drive at one end and the motor at the other.

- 6** Connect the earth/ground wire to the earth/ground terminal.  
Maximum wire sizes:  
Frame F: 95mm<sup>2</sup>/ 4/0AWG (without crimp)  
95mm<sup>2</sup>/ 4/0AWG (with crimp)

- 7** Connect the 3-phase supply.  
Maximum wire sizes:  
Frame F: 95mm<sup>2</sup>/ 4/0AWG (without crimp)  
95mm<sup>2</sup>/ 4/0AWG (with crimp)

- 8** Connect the 115 or 220Vac auxiliary supply for the internal fans to AUX 1 and AUX 2 (in any order).

See block 5 of the Model Number:  
1F = 115Vac, 2F = 220Vac.

- 9** Connect the brake resistor.  
Maximum wire sizes:  
Frame F: 95mm<sup>2</sup>/ 4/0AWG (without crimp)  
95mm<sup>2</sup>/ 4/0AWG (with crimp)

- An External Braking Resistor is optional. Connect it between DBR+ and DBR- for high inertial loads.

*DO NOT* apply external voltage sources (mains supply or otherwise) to the braking terminals.

We recommend using a thermal overload switch to protect the braking circuit.

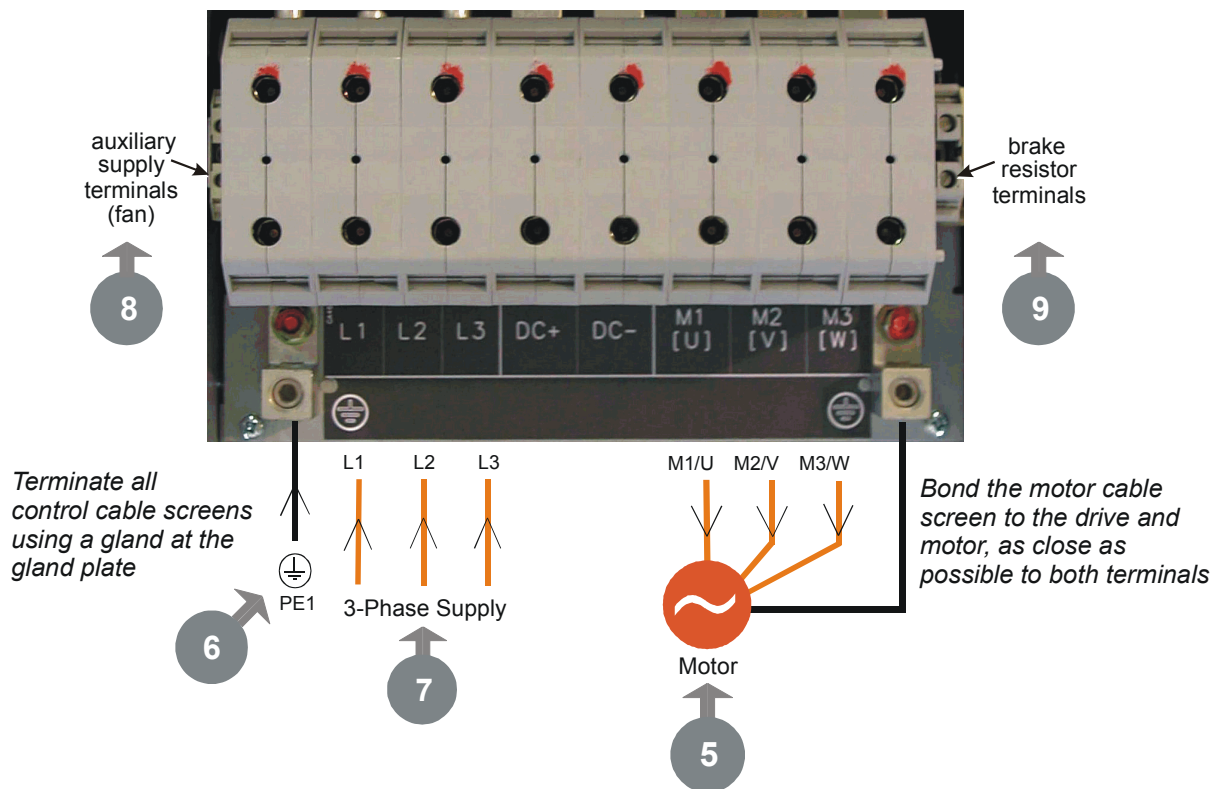

# 890SD Control Connections

## A Speed Reference

- Connect a 10kΩ potentiometer at terminal block X12 (Analog I/P 3)
- High (CW): terminal X12/08
- Wiper: terminal X12/04
- Low (CCW): terminal X12/01
- Connect the shield to earth/ground

OR

- External 2-wire speed reference between terminals X12/01(-) and X12/04(+)
- Connect the shield to earth ground

## B Sequencing

- Connect volt-free contacts as required
- RUN (maintained contact) terminal X14/03 and terminal X15/02

## C Thermistor

- Connect motor thermal switch or thermistor to terminals X16/08 & X16/09. Drive will trip when the thermal switch opens, or when the thermistor resistance exceeds 4kΩ maximum (PTC Type A : IEC 34-11 Part 2)
- If the motor does not have a protective device (thermistor), jumper these terminals. The drive needs the thermistor inputs connected for it to run.

## Analog

- SPEED FEEDBACK  
10V = ±100% speed at terminal X12/0 6
- TORQUE FEEDBACK  
10V = ±200% torque at terminal X12/07
- ANALOG COMMON  
0V at terminal X12/0 1

## Digital

- DRIVE HEALTH  
Relay dry contact (24V rated) at terminal X14/01 and terminal X14/02
- RUNNING  
24V sourcing output at terminal X15/08
- ZERO SPEED  
24V sourcing output at terminal X15/09
- DIGITAL COMMON  
0V at terminal X14/04

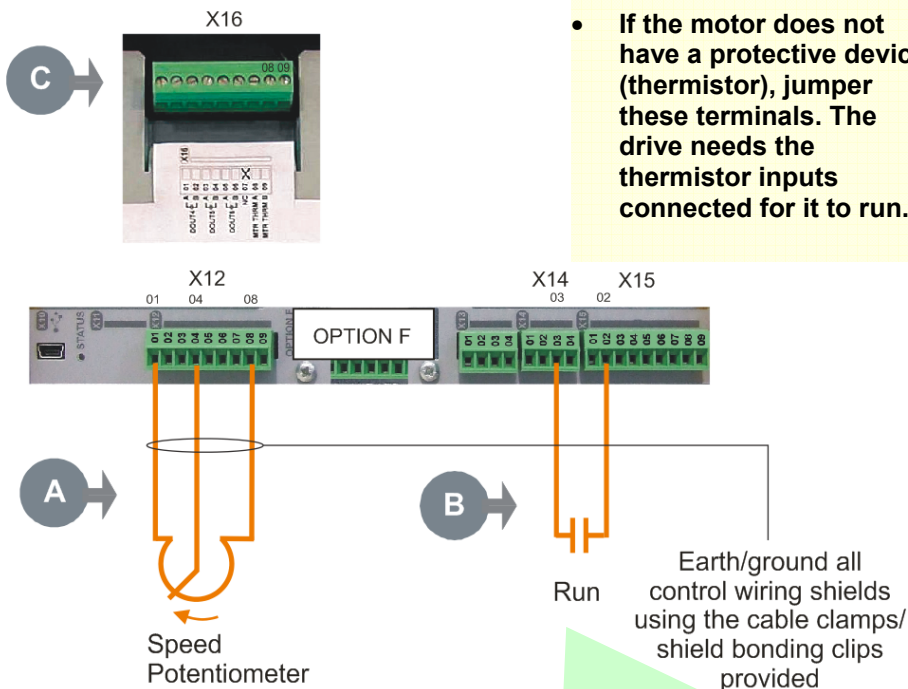

The control terminals will accept a single wire of size 1.5mm<sup>2</sup>/16AWG. For two wires per terminal, use smaller gauge wire such as 0.5mm<sup>2</sup>/22AWG.

This is a basic connection diagram.

For more detailed information on control connections, refer to Appendix B.

# 890SD Feedback Connections

**This section is only for closed loop vector and induction servo applications. Skip this page if there is no encoder or resolver mounted on the motor.**

## Incremental Pulse Encoders

The default settings for the drive are for 2048 line, quadrature, incremental pulse encoders with differential outputs operating from a 10VDC supply.

- Z channel (Marker pulse) connections are not necessary for running the drive, but inputs are provided for positioning and servo applications. The supply voltage to the encoder is set in the Quick Setup menu. Range 10 VDC to 20 VDC

### Use the Keypad to set the following options:

Supply Voltage - PULSE ENC VOLTS

Number of lines per revolution - ENCODER LINES parameter

\* Encoder direction - ENCODER INVERT

*\* Used to match the encoder direction to the motor direction. When TRUE, changes the sign of the measured speed and the direction of the position count. It is necessary to set up this parameter when in CLOSED-LOOP VEC mode, as the encoder direction must be correct for this mode to operate.*

Using other types of encoders requires the 890 DSE Configuration Tool and the the setting of other parameters. Refer to the 890 Engineering Reference Manual for details of these parameters.



### OPTION F Terminal Block

01	Shield
02	Supply -
03	Supply +
04	Channel Z/
05	Channel Z
06	Channel B/
07	Channel B
08	Channel A/
09	Channel A

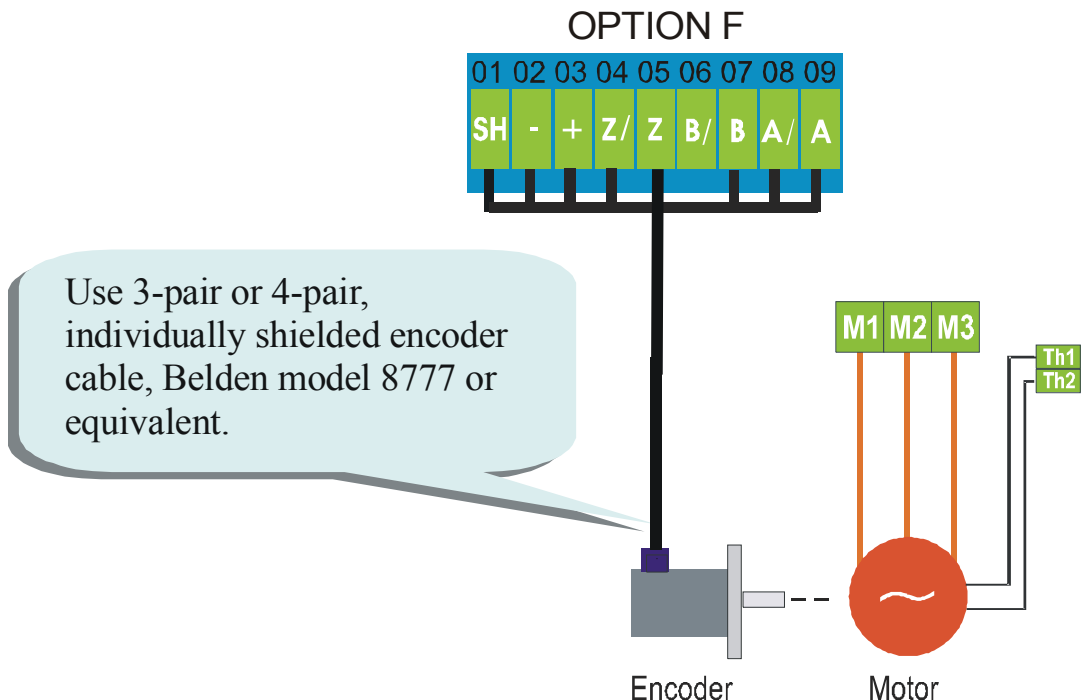

# Drive Start-up

## Before Applying Power :

- Read the Safety section at the front of the QuickStart.
- Ensure that all local electric codes are met.
- Check for damage to equipment.
- Check for loose ends, clippings, filings, drilling swarf etc. lodged in the drive and system.
- Check all external wiring circuits of the system - power, control, motor and earth connections.
- Ensure that unexpected rotation of the motor in either direction will not result in damage, bodily harm or injury. Disconnect the load from the motor shaft, if possible.
- Check the state of the Motor Thermistor and Brake Resistor connectors. Check external run contacts are open. Check external speed setpoints are all at zero.
- Ensure that nobody is working on another part of the system which will be affected by powering up.
- Ensure that other equipment will not be adversely affected by powering up.
- Check motor stator connections are correctly wired for for Star or Delta as necessary for drive output voltage.

**If all connections have been checked, it is time to **POWER-UP** the drive**

# Drive Set-up

Appendix A contains information about the 6901 keypad menus and parameter names.

## Motor Data

Before attempting to set up the drive, you will need some motor information. This is found on the motor nameplate. The information you will need is listed below:

- Base Volts
- Base frequency
- Base RPM
- Full load amps
- No load amps (mag current)
- Connection (star or delta)

## Quick Setup Parameters

The following is a list of the Quick Setup parameters you must check before starting the drive. Set only the ones marked with “x” in the table below, under the intended mode of operation.

		<u>V/Hz</u>	<u>SV</u>	<u>Vector</u>
Control Mode	Select the intended operating mode	x	x	x
Max Speed	Motor RPM at full process speed	x	x	x
V/F shape	Usually Linear. Choose fan curve only for fans	x		
Motor Current	Motor full load current from motor nameplate	x	x	x
Motor Base Freq	Motor nameplate frequency	x	x	x
Motor Voltage	Motor nameplate voltage	x	x	x
Nameplate RPM	Motor nameplate RPM	x	x	x
Motor Poles	<i>See Note</i>		x	x
Pulse Enc Volts	Set between 10-20V to match encoder			x
Encoder Lines	Pulses per Revolution of encoder			x
Encoder Invert	Changes polarity of encoder feedback			x
Autotune Enable	Drive will Autotune if started		x	x
Mag Current	Enter the No-Load Amps from the motor nameplate	x	x*	x*

\* if performing a Stationary Autotune.

**NOTE** Some of the parameters are product code dependent, that is, they are different for each frame size and power rating. For example, the unit will be set for either 50Hz or 60Hz operation:

**Motor Poles for 60Hz** 2 poles = 3600 rpm, 4 poles = 1800 rpm, 6 poles = 1200 rpm  
**Motor Poles for 50Hz** 2 poles = 3000 rpm, 4 poles = 1500 rpm, 6 poles = 1000 rpm

# Autotune

**This section is only for operating in Sensorless or Closed-loop Vector modes.  
If the drive is in V/Hz mode, Autotune is unnecessary and will not Enable.**

- Ensure that MAX SPEED is greater than NAMEPLATE RPM for a successful autotune.
- In the QUICK SETUP menu, set AUTOTUNE ENABLE to TRUE.

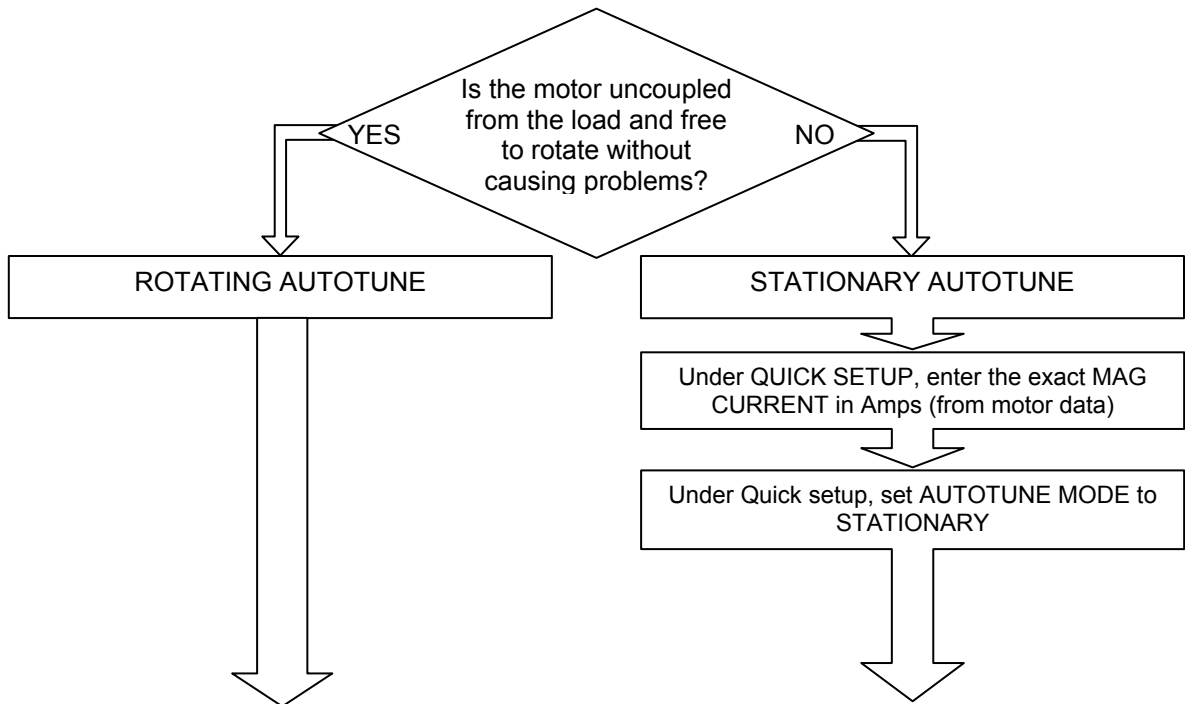

- On the 890CD keypad select LOCAL mode. Set SETPOINT (LOCAL) to 0.0%.
- Press the green RUN button. The drive will begin autotuning. The drive will stop without errors if autotune is successful.
- Go to SYSTEM::SAVE CONFIG::APPLICATION and UP arrow to save your settings.

# Running in Local

- On the keypad select LOCAL mode. The display will show the Local Setpoint : 0.0%
- Use the UP arrow to set a Local Setpoint, say 20%.
- Press the green RUN button. The motor will accelerate to the desired speed and maintain it. Adjust RAMP ACCEL TIME in Quick Setup to the desired level.
- Press the red STOP button. The motor will decelerate to a stop. Adjust RAMP DECEL TIME in Quick Setup to desired level. If the drive trips on Overvoltage, extend the RAMP DECEL TIME or connect a braking resistor. Refer to the 890 Engineering Reference Manual.

Go to SYSTEM::SAVE CONFIG::APPLICATION and UP arrow to save your settings Values are stored during power-down.

# Running in Remote

- On the keypad select REMOTE mode. The display will show the remote Setpoint : ?.?% (The value displayed depends on the external speed reference).
- Dial in a speed setpoint using the Speed potentiometer until the display reads 20%.
- Start the drive by closing the Start contact between terminal X14/03 and terminal X15/02. The motor will accelerate to the desired speed and maintain it. Adjust RAMP ACCEL TIME in Quick Setup to the desired level.
- Open the Start contact. The motor will decelerate to a stop. Adjust RAMP DECEL TIME in Quick Setup to desired level. If the drive trips on Overvoltage, extend the RAMP DECEL TIME or connect a braking resistor. Refer to the 890 Engineering Reference Manual..

Go to SYSTEM::SAVE CONFIG::APPLICATION and UP arrow to save your settings Values are stored during power-down.

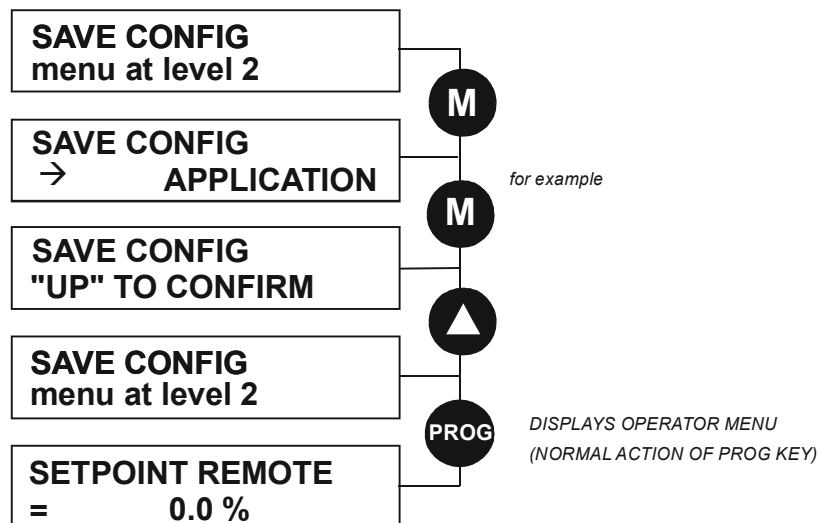



# Appendix A: Using the 6901 Keypad

The 6901 keypad has a two-line backlit LCD display with units and symbols. It can be used to setup and configure the 890 in plain language. It can also be used to operate the drive in Local mode from its Start and Stop buttons, Jog and reverse.



**To display the Software Version and Voltage Rating:**

Press **E** repeatedly to display the Welcome Screen

Press **M** to return to the Menus

**To Start in Local Mode:**

Press **I**

**To Stop in Local Mode:**

Press **STOP**

SEQ and REF LEDs are On when in Local mode

<b>Menus :</b>	<b>E</b> exit a menu	<b>M</b> sub-menu or parameter	<b>▲</b> scroll up	<b>▼</b> scroll down
<b>Parameters :</b>	<b>E</b> exit parameter	<b>M</b> make writable	<b>▲</b> previous parameter	<b>▼</b> next parameter
<b>Edit</b>	<b>E</b> stop editing	<b>M</b> show PREF (hold)	<b>▲</b> increment value	<b>▼</b> decrement value

**To change Operating Mode:**  
From power-up, the keypad displays the Software Version, and then times-out to show the Remote Setpoint.

Mode	Action
Remote to Local	Toggle between modes using the L/R key <b>L/R</b> SEQ and REF LEDs are On when in Local
Local to Remote	Toggle between modes using the L/R key <b>L/R</b> SEQ and REF LEDs are Off when in Remote

# The Menu Structure

The main menus are shown below. Each menu contains parameters.

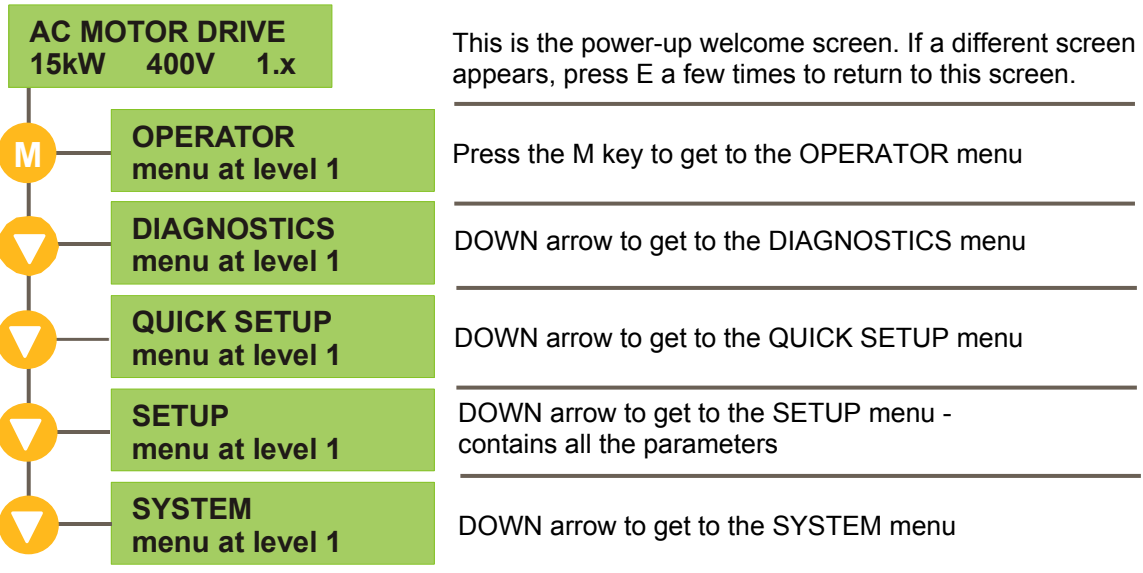

**NOTE** Refer to the Engineering Reference Manual for a list of available parameters.

# Appendix B: Analog and Digital I/O

The terminal function names apply to the factory shipping configuration. These terminals may have different functions if the configuration has been modified using DSE.

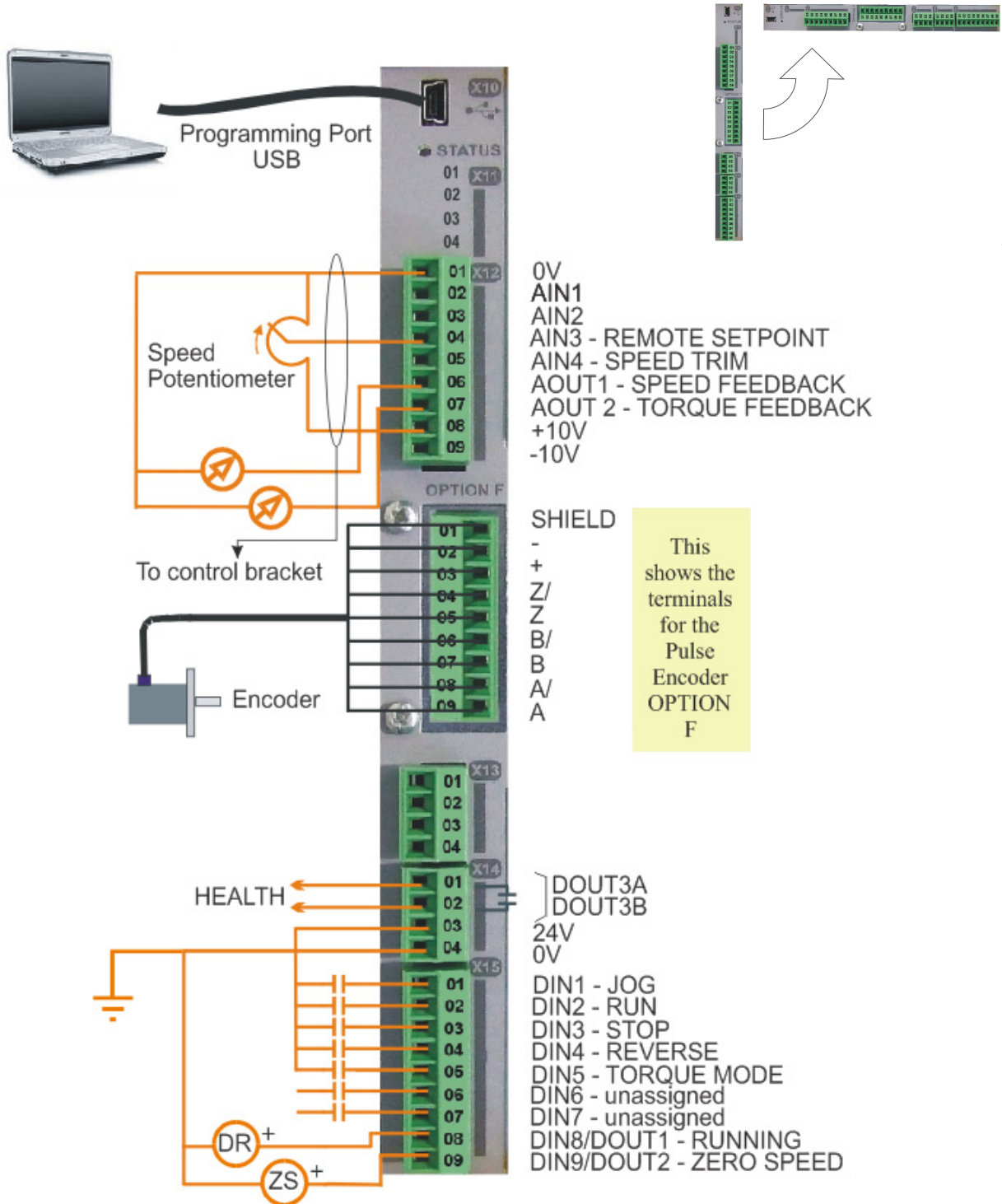

# 890SD Control Terminals

The terminal function names apply to the factory shipping configuration. These terminals may have different functions if the configuration has been modified using DSE.

- Analog I/O connector is X12
- Analog I/O resolution is 12 bit plus sign
- Digital I/O connector is X15
- Digital I/O is 24VDC, sourced, active high

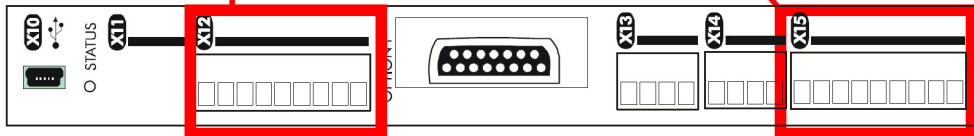

Terminal	Name	Range	Description
<b>ANALOG I/O</b>			
X12/01	0V		0V reference for analog I/O
X12/02	AIN1	0-10V, ±10V	Analog Input 1 Configurable (default = diff I/P +)
X12/03	AIN2	0-10V, ±10V	Analog Input 2 Configurable (default = diff I/P -)
X12/04	AIN3	±10V, 0-10V, 0-20mA, 4-20mA	Analog Input 3 Configurable (default = remote setpoint I/P)
X12/05	AIN4	±10V, 0-10V, 0-20mA, 4-20mA	Analog Input 4 Configurable (default = speed trim I/P)
X12/06	AOUT1	±10V (10V=100%speed)	Analog Output 1 Configurable (default = speed feedback O/P)
X12/07	AOUT2	±10V (10V=200% torque)	Analog Output 2 Configurable (default = torque feedback O/P)
X12/08	+10V REF	+10V	10V reference for analog i/o. Load 10mA maximum
X12/09	-10V REF	-10V	10V reference for analog i/o. Load 10mA maximum
<b>DIGITAL I/O</b>			
X15/01	DIN1	0 or 24V	Configurable Digital Input 1 (default = Jog)
X15/02	DIN2	0 or 24V	Configurable Digital Input 2 (default = Run)
X15/03	DIN3	0 or 24V	Configurable Digital Input 3 (default = Stop)
X15/04	DIN4	0 or 24V	Configurable Digital Input 4 (default = Reverse)
X15/05	DIN5	0 or 24V	Configurable Digital Input 5 (default = Torque mode)
X15/06	DIN6	0 or 24V	Configurable Digital Input 6 (default = Unassigned)
X15/07	DIN7	0 or 24V	Configurable Digital Input 7 (default = Unassigned)
X15/08	DIN8/DOUT1	0 or 24V	Configurable Digital Input/output (default : digital input = Running)
X15/09	DIN9/DOUT2	0 or 24V	Configurable Digital Input/output (default : digital input = Zero Speed)

# Appendix C: Electrical Ratings

<b>890SD Frame E, 400V</b> Power Supply = 380-460V ±10%, 50/60Hz ±5% Motor power, output current and input current must not be exceeded under steady state operating conditions. Input currents listed at 400Vac 50Hz for kW ratings and 460Vac 60Hz for Hp ratings.									
Model Number (Europe)	Catalog Number (North America)	Motor Power	Output Current (A) (note 1)	AC Input Current (A)	Heatsink Power Loss (W)	Total Power Loss (W)	Maximum Switching Frequency (kHz)	Input Bridge $I_t^2$ (A <sup>2</sup> s)	Brake Switch Peak Current (A) (note 2)
<b>FRAME E :</b> Prospective short circuit current 18kA.									
<b>Constant Torque</b> (Output Overload Motoring 150% for 60s, 180% for 0.5s short term rating)									
890SD/4/0073E/..		37kW	73	81	730	850	3, 6	18000	50
	890SD/4/0073E/..	50Hp	73	68	730	850	3, 6	18000	50
890SD/4/0087E/..		45kW	87	95	880	880	3, 6	18000	60
	890SD/4/0087E/..	60Hp	87	80	880	880	3, 6	18000	60
<b>Quadratic Torque</b> (Output Overload Motoring 110% for 60s)									
890SD/4/0073E/..		45kW	87	95	901	1029	3	18000	50
	890SD/4/0073E/..	60Hp	87	80	901	1029	3	18000	50
890SD/4/0087E/..		55kW	105	110	1094	1242	3	18000	60
	890SD/4/0087E/..	75Hp	105	95	1094	1242	3	18000	60

Note 1: Up to the highest supply voltage that maintains shaft power less than the product power rating, for a typical induction motor. Derated for operation above this supply voltage.

Note 2: 20s maximum, 30% duty. DC link brake voltage: 750V

## 890SD Frame F, 400V

Power Supply = 380-460V ±10%, 50/60Hz ±5%

Motor power, output current and input current must not be exceeded under steady state operating conditions. Input currents listed at 400Vac 50Hz for kW ratings and 460Vac 60Hz for Hp ratings.

Model Number (Europe)	Catalog Number (North America)	Motor Power	Output Current (A) (note 1)	AC Input Current (A)	Heatsink Power Loss (W)	Total Power Loss (W)	Maximum Switching Frequency (kHz)	Input Bridge $I_t^2$ (A <sup>2</sup> s)	Brake Switch Peak Current (A) (note 2)
-----------------------	--------------------------------	-------------	-----------------------------	----------------------	-------------------------	----------------------	-----------------------------------	---	--

**FRAME F :** Prospective short circuit current 18kA.

**Constant Torque** (Output Overload Motoring 150% for 60s, 180% for 0.5s short term rating)

890SD/4/0105F/..	890SD/4/0105F/..	55kW 75Hp	105 100	114 99	920 900	1220 1130	3 3	100,000 100,000	125 125
890SD/4/0145F/..	890SD/4/0145F/..	75kW 100Hp	145 130	143 124	1320 1200	1670 1500	3 3	100,000 100,000	136 136
890SD/4/0156F/..	890SD/4/0156F/..	90kW 125Hp	180 156	164 148	1490 1340	1950 1780	3 3	100,000 100,000	136 136
890SD/4/0180F/..	890SD/4/0180F/..	110kW 150Hp	180 180	164 169	1490 1670	1950 2180	3 3	100,000 100,000	136 136

**Quadratic Torque** (Output Overload Motoring 110% for 60s)

890SD/4/0105F/..	890SD/4/0105F/..	75kW 100Hp	145 125	143 124	1400 1200	1670 1500	3 3	100,000 100,000	125 125
890SD/4/0145F/..	890SD/4/0145F/..	90kW 125Hp	165 156	164 148	1580 1340	1950 1780	3 3	100,000 100,000	136 136
890SD/4/0156F/..	890SD/4/0156F/..	110kW 150Hp	205 180	195 169	1800 1670	1950 2180	3 3	100,000 100,000	136 136
890SD/4/0180F/..	890SD/4/0180F/..	110kW 150Hp	205 180	195 169	1800 1670	1950 2180	3 3	100,000 100,000	136 136

Note 1:

Up to the highest supply voltage that maintains shaft power less than the product power rating, for a typical induction motor. Derated for operation above this supply voltage.

Note 2:

20s maximum, 30% duty. DC link brake voltage: 750V

## 890SD Frame E, 500V

Power Supply = 380-500V ±10%, 50/60Hz ±5%

Motor power, output current and input current must not be exceeded under steady state operating conditions. Input currents listed at 500Vac 50Hz for kW ratings.

500V unit full power ratings are only available at 500V. The unit can be operated between 380-500V supply voltage with reduced output power below 500V.

Model Number (Europe)	Catalog Number (North America)	Motor Power	Output Current (A) (note 1)	AC Input Current (A)	Heatsink Power Loss (W)	Total Power Loss (W)	Maximum Switching Frequency (kHz)	Input Bridge $I_{T}^2$ (A <sup>2</sup> s)	Brake Switch Peak Current (A) (note 2)
<b>FRAME E :</b> Prospective short circuit current 18kA.									
<b>Constant Torque (Output Overload Motoring 150% for 60s, 180% for 0.5s short term rating)</b>									
890SD/5/0073E/..	-	37kW	67	69	799	911	3, 6	18000	46
890SD/5/0087E/..	-	45kW	79	82	957	1083	3, 6	18000	55
<b>Quadratic Torque (Output Overload Motoring 110% for 60s)</b>									
890SD/5/0073E/..	-	45kW	79	82	766	894	3	18000	46
890SD/5/0087E/..	-	55kW	98	98	930	1078	3	18000	55

Note 1: Up to the highest supply voltage that maintains shaft power less than the product power rating, for a typical induction motor. Derated for operation above this supply voltage.

Note 2: 20s maximum, 30% duty. DC link brake voltage: 820V

## 890SD Frame F, 500V

Power Supply = 380-500V ±10%, 50/60Hz ±5%

Motor power, output current and input current must not be exceeded under steady state operating conditions. Input currents listed at 500Vac 50Hz for kW ratings.

500V unit full power ratings are only available at 500V. The unit can be operated between 380-500V supply voltage with reduced output power below 500V.

Model Number (Europe)	Catalog Number (North America)	Motor Power	Output Current (A) (note 1)	AC Input Current (A)	Heatsink Power Loss (W)	Total Power Loss (W)	Maximum Switching Frequency (kHz)	Input Bridge $i_t^2$ (A <sup>2</sup> s)	Brake Switch Peak Current (A) (note 2)
<b>FRAME F :</b> Prospective short circuit current 18kA.									
<b>Constant Torque</b> (Output Overload Motoring 150% for 60s, 180% for 0.5s short term rating)									
890SD/5/0105F/..	-	55kW	100	93	900	1130	3	100,000	82
890SD/5/0145F/..	-	75kW	125	118	1200	1500	3	100,000	102
890SD/5/0156F/..	-	90kW	156	140	1340	1780	3	100,000	102
<b>Quadratic Torque</b> (Output Overload Motoring 110% for 60s)									
890SD/5/0105F/..	-	75kW	125	118	1200	1500	3	100,000	82
890SD/5/0145F/..	-	90kW	156	140	1340	1780	3	100,000	102
890SD/5/0156F/..	-	110kW	180	166	1670	2180	3	100,000	102

Note 1: Up to the highest supply voltage that maintains shaft power less than the product power rating, for a typical induction motor. Derated for operation above this supply voltage.

Note 2: 20s maximum, 30% duty. DC link brake voltage: 820V