

## CLONING

650V drives may be cloned using the 6514 Clone option that plugs into the keypad port. Settings include to/from, I/O configuration and full/part transfer.



## SERIAL COMMS

The Serial Communication option is factory installed and must be ordered with the drive. It can be used to exchange information between the Master and Slave drives in RS485/232 format. Up to 32 units can be connected together.

## ADVANCED FEATURES

The 650V has additional features which can be accessed via the drive menu or using CE\_Lite. Refer to the product manual for details.

**Flycatching** - When enabled, lets the drive start into a spinning load by doing a frequency search.

**Skip Frequencies** – Two selectable avoidance frequencies and associated window for each.

**PID** – Provides closed loop process control

**S-Ramp** – When enabled, introduces a second order slope to the ramp for smoother transitions.

**Configurable Outputs** – The digital outputs on the 650 can be configured to pick one of 6 parameters. The outputs on the 650V are totally configurable.

**Auto Restart** - After a fault, the drive attempts a number of restarts after a settable delay.

**Custom Screens** - Allows the use of a Custom parameter to be displayed.

**Encoder** – Terminals 12 & 13 can be used for a quadrature (not complementary) encoder input for steady-state speed feedback.



# 650V Quick Start



## Sensorless Vector Volts/Hertz Inverters

**frames C-F**  
**15-150 HP**  
**7.5-90 kW**

Visit us at [www.ssddrives.com](http://www.ssddrives.com)

USA: (704) 588-3246 UK: +44 (0)1903 737000

HA470679U200 Issue 4



### Associated Literature

650V Installation Manual HA467652Uxxx  
650V Software Manual HA466358Uxxx

## BEFORE YOU START

This document covers the steps necessary for a basic start up of the 690+ drive. Drive start ups should be performed by qualified electrical technicians who are familiar with AC drives and their applications. For detailed installation and safety information refer to the Installation Manual. For advanced features and applications, refer to the Software Manual.

Ensure that all local electric codes are met while installing the drive. Check that all live parts are covered to protect against electric shock and that unexpected rotation of the motor will not result in bodily harm or injury.

This document expects that the drive is already installed in its intended location and that all relevant installation procedures have been followed. Please ensure that the drive has adequate ventilation so that ambient temperature does not exceed 45°C (112°F) under normal operating conditions.

To access the terminals, loosen the two retaining screws at the bottom of the drive, pull up gently on the terminal cover and slide it off.

## CONTROL MODES

**Volts/Hertz** mode – Basic open loop operation, used in fans/pumps and multi-motor applications.

**Sensorless Vector** mode – Tight speed regulation with good transient torque capability, without the need for speed feedback.

## POWER CONNECTIONS

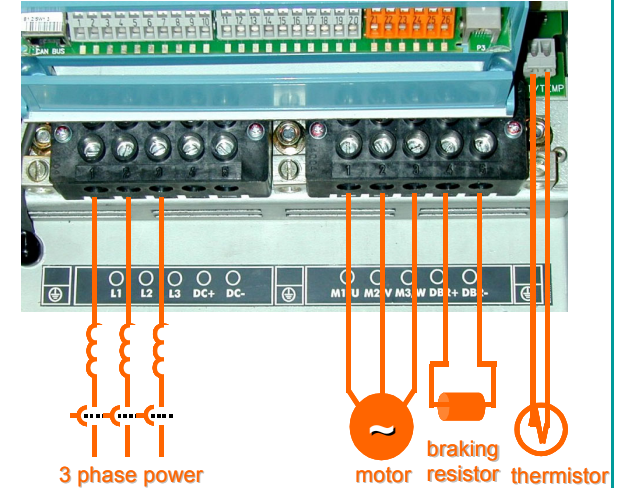

The power terminals shown are for frame D. Although other frames may vary slightly in appearance, their terminal designations and functionality are identical. However, the Frame F unit requires an auxiliary supply for the cooling fan. Refer to Chapter 3.

- 3-phase supply to L1, L2, L3.
- Motor connections to M1, M2, M3
- Brake resistor between DBR+, DBR-
- Motor thermistor to MOT TEMP
- Common Bus to DC+, DC-
- Frame F only: 115/230V fan supply to L,N

Ground lugs have been provided for each of the power circuits. Follow proper grounding and shielding methods as described in chapter 3 of the Installation Manual,

If the stop time is expected to be less than the natural coasting time of the load, order the factory mounted braking module option on frames D through F. Frame C has a built-in braking module. Connect the braking resistor across DBR+ and DBR-.

## REFERENCE AND SEQUENCING

- Speed potentiometer: 1 (Low), 4 (High), 2 (Wiper) OR
- External speed reference: 1(-) and 2(+)

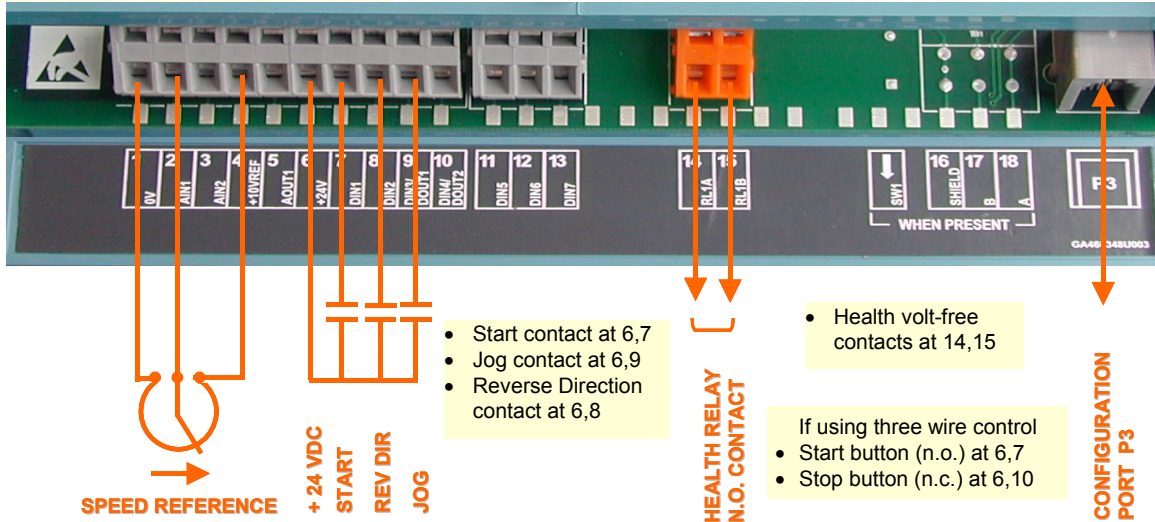

- Start contact at 6,7
- Jog contact at 6,9
- Reverse Direction contact at 6,8

- Health volt-free contacts at 14,15

- If using three wire control
- Start button (n.o.) at 6,7
- Stop button (n.c.) at 6,10

## CALIBRATION

All calibration is done in software, through the keypad

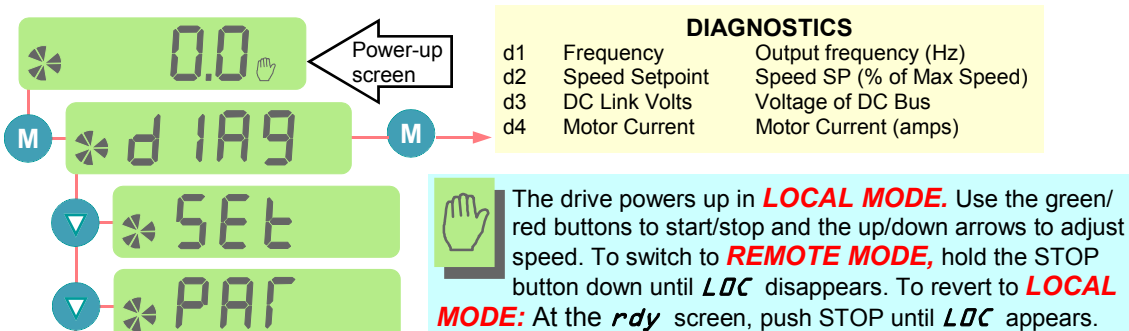

### SETUP PARAMETERS

**SAVING**  
Changes take effect as soon as they are entered and parameters are saved automatically in a few seconds

Parameter	Description	Setting
P1	Application Select	Select the application macro
P2	Max Speed	Set max speed in Hz
P3	Min Speed	Set min speed in %
P4	Acceleration time	Accel time to Max Speed in sec
P5	Deceleration time	Decel time from Max Speed in sec
P6	Motor Current	Motor full load current in amps
P7	Base Frequency	Motor nameplate frequency in Hz
P8	Jog Setpoint	Set jog speed in % of max speed
P9	Stop Mode	0=Ramp; 1=Coast; 2=Injection braking
P11	V/Hz shape	0=Linear; 1=Quadratic (fan or square)
P12	Overload Rating	0=150% for 30s.; 1=110% for 10s.
P13	Fixed Boost	Set boost in % volts (V/Hz mode only)
P99	Password	Set from 0001 to FFFF for protection

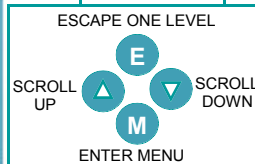

## APPLICATION MACROS

After the first power-up, the 650 defaults to the most basic mode of operation, namely speed control. In addition, it has the capability of being configured for special applications by loading the correct Application Macro.

**Selecting an Application:** Applications may be loaded during power-up by pressing and holding the STOP button, or by setting P1 from the Parameters menu. 1=Speed Control; 2=Manual/Auto; 3=Preset Speeds; 4=Raise/Lower; 5=PI Control; 6=Torque Reference (650Vonly); 9=Custom (650Vonly)

**Terminal Assignments:** Different applications require different setup parameters, inputs and outputs. When an application is selected, the 650 internally reassigns its control terminals for the relevant functionality. Also, depending on the application selected, an enhanced application-specific set of parameters will be visible, in addition to the regular parameters.

	SPEEDCONTROL P1=1	MANUAL/AUTO P1=2	PRESET SPEEDS P1=3	RAISE/LOWER P1=4	PI CONTROL P1=5
<b>App-Specific Parameters</b>	None	IP23 ANIN2 type OP21 DIGIO2 OP31 Relay	IP301 Preset 1 IP302 Preset 2 IP303 Preset 3 IP304 Preset 4 IP305 Preset 5 IP306 Preset 6 IP307 Preset 7 IP308 Preset 8	P401 Ramp Time P402 Max Value P403 Min Value P404 Reset Value	P501 Prop. Gain P502 Integral Gain
<b>Control Terminal Assign</b>	1 Common 0V 2 Speed In (V) 3 Speed In (mA) 4 +10V Supply 5 Speed Output 6 +24V Supply 7 Start button 8 Fwd/Rev 9 Jog 10 Stop button	1 Common 0V 2 Manual Ref (V) 3 Auto Ref (mA) 4 +10V Supply 5 Speed Output 6 +24V Supply 7 Manual Start 8 Auto Start 9 Man/Auto 10 Fwd/Rev	1 Common 0V 2 Speed In (V) 3 Speed In (mA) 4 +10V Supply 5 Speed Output 6 +24V Supply 7 Start 8 Preset Digital 1 9 Preset Digital 2 10 Preset Digital 3	1 Common 0V 2 Unused 3 Unused 4 +10V Supply 5 Speed Output 6 +24V Supply 7 Start 8 Raise Input 9 Lower Input 10 Ramp Reset	1 Common 0V 2 Reference (V) 3 Feedback (mA) 4 +10V Supply 5 Speed Output 6 +24V Supply 7 Start button 8 Fwd/Rev 9 Jog 10 Stop button

## AUTOTUNE

Autotune will not activate if in V/Hz mode.

For sensorless vector (SV) operation, an autotune is highly recommended, preferably with the motor uncoupled and free to rotate. (if the motor cannot be uncoupled, set CL20=0. See below).

### CONTROL PARAMETERS

Parameter	Description	Setting
CL01	Control Mode	0 = V/Hz; 1 = Sensorless Vector (SV)
CL02	Nameplate RPM	Enter RPM from motor nameplate
CL10	Motor Current	Enter full load amps from motor nameplate
CL11	Motor Poles	2=3600rpm; 4=1800rpm; 6=1200rpm
CL12	Motor Voltage	Enter motor nameplate voltage
CL20	Autotune Mode	0=stationary; 1=rotating (preferred)
CL21	Autotune Enable	set to 1 and run the drive to autotune
CL81	Current Limit	Current Limit setting as a % of CL10

POWER ON