

CLONING

650 and 650V drives may be cloned using the 6514 Clone option that plugs into the keypad slot. Settings include to/from, I/O configuration and full/part transfer.



SERIAL COMMS

The 6513 Serial Communication option can be plugged into the keypad slot. It can be used to exchange information between the Master and Slave drives in RS485/232 format, up to 32 units can be connected together. Front panel LED in-

ADVANCED FEATURES

The 650 has additional features which can be accessed via the drive menu, or for the 650V using CE_Lite. Refer to the product manual for details.

Flycatching - When enabled, lets the drive start into a spinning load by doing a frequency search.

Skip Frequencies – Two selectable avoidance frequencies and associated window for each.

PID – Provides closed loop process control

S-Ramp – When enabled, introduces a second order slope to the ramp for smoother transitions.

Configurable Outputs – The digital outputs on the 650 can be configured to pick one of 6 parameters. The outputs on the 650V are totally configurable.

Auto Restart - After a fault, the drive attempts a number of restarts after a settable delay.

Custom Screens - Allows the use of a Custom parameter to be displayed. (650V only)

Encoder – Terminals 12 & 13 (650V only) can be used for a quadrature (not complementary) encoder input for steady-state speed feedback.

Associated Literature

650	Installation Manual	HA464828Uxxx
650	Software Manual	HA467872Uxxx
650V	Installation Manual	HA467649Uxxx
650V	Software Manual	HA466358Uxxx



650 series Quick Start



Sensorless (model 650V) Volts/Hertz (model 650) Inverters

frames 1-3

Visit us at www.SSDdrives.com

USA: (704) 588-3246 UK: +44 (0)1903 737000
HA470679U100 Issue 2

HA470679U100

BEFORE YOU START

This document covers the steps necessary for a basic start-up of the 650 drive. Drive start ups should be performed by qualified electrical technicians who are familiar with AC drives and their applications. For detailed installation and safety information refer to the Instruction Manual.

Ensure that all local electric codes are met while installing the drive. Check that all live parts are covered to protect against electric shock and that unexpected rotation of the motor will not result in bodily harm or injury.

This document expects that the drive is already installed in its intended location and that all relevant installation procedures have been followed. Please ensure that the drive has adequate ventilation so that ambient temperature does not exceed 40°C (104°F) under normal operating conditions.

To access the terminals, slide down the terminal cover, while applying slight pressure on the drive label.

FRAME RATINGS

Frame 1	0.3 – 1 HP 0.25 – 0.75kW	230VAC 1 ph
Frame 2	1.5 – 2 HP 1.1 – 1.5kW 0.5 – 3 HP 0.37 – 2.2kW	230VAC 1 ph 460VAC 3 ph 400VAC
Frame 3	3 – 5 HP 2.2 – 4kW 5 – 10 HP 3 – 7.5kW	230VAC 3 ph 460VAC 3 ph 400VAC

For larger sizes, see 650V Quickstart

CONTROL MODES

Volts/Hertz mode (650 & 650V) – Basic open loop operation, used in fans/pumps and multi-motor applications.

Sensorless Vector mode (650V only) – Tight speed regulation with good transient torque capability, without the need for speed feedback.

POWER CONNECTIONS

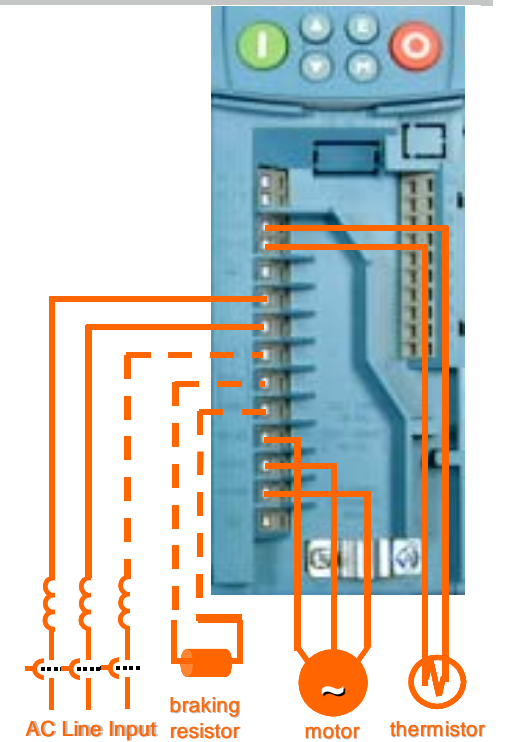

The power terminals shown are for frame 2. Although other frames may vary slightly in appearance, their terminal designations and

- Single-phase supply to L1, L2/N.
- 3-phase supply to L1, L2, L3.
- Motor connections to M1, M2, M3.
- Brake resistor between DC+, DBR
NOTE: Frame 1&2 230V units are not fitted with a braking module. Do not use a braking resistor on them.

- Motor thermistor to Th1A, Th1B.
- Ground lugs are provided for each power circuit. Follow proper grounding and shielding methods as described in the Instruction Manual.

If stop time is expected to be less than the natural coasting time of the load, connect the braking resistor across DC+ and DBR (see Brake resistor note above)

REFERENCE AND SEQUENCING

- Speed potentiometer: 1 (Low), 4 (High), 2 (Wiper) OR

- If using three wire control
- Start button (n.o.) between 6,7
 - Stop button (n.c.) between 6,10

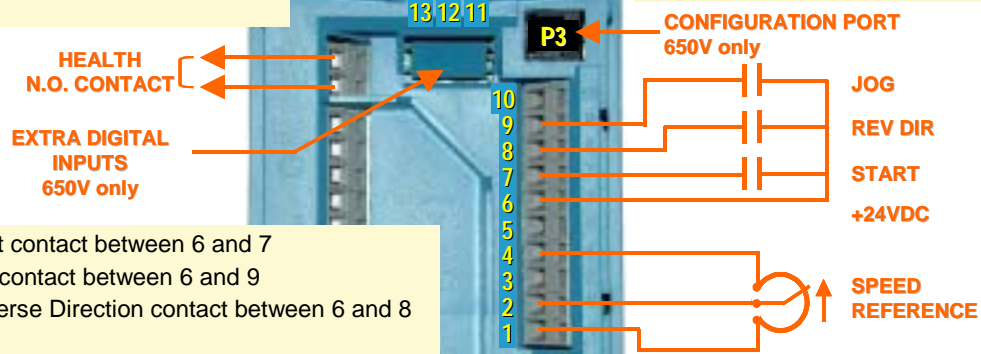

CALIBRATION

All calibration is done in software, through the keypad

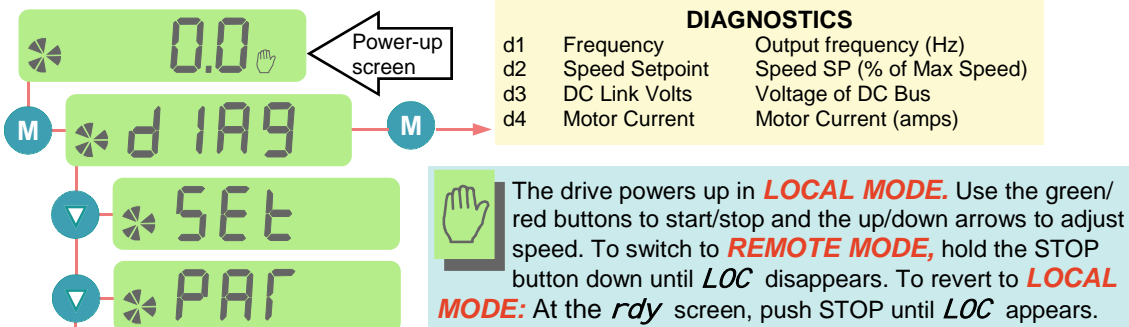

SETUP PARAMETERS

Parameter	Description	Setting
P1	Application Select	Select the application macro
P2	Max Speed	Set max speed in Hz
P3	Min Speed	Set min speed in %
P4	Acceleration time	Accel time to Max Speed in sec
P5	Deceleration time	Decel time from Max Speed in sec
P6	Motor Current	Motor full load current in amps
P7	Base Frequency	Motor nameplate frequency in Hz
P8	Jog Setpoint	Set jog speed in % of max speed
P9	Stop Mode	0=Ramp; 1=Coast; 2=Injection braking
P11	V/Hz shape	0=Linear; 1=Quadratic (fan or square)
P12	Overload Rating	0=150% for 30s.; 1=110% for 10s.
P13	Fixed Boost	Set boost in % volts (V/Hz mode only)
P99	Password	Set from 0001 to FFFF for protection

SAVING
Changes take effect as soon as they are entered and parameters are saved automatically in a few seconds

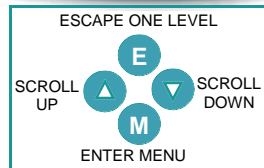

APPLICATION MACROS

After the first power-up, the 650 defaults to the most basic mode of operation, namely speed control. In addition, it has the capability of being configured for special applications by loading the correct Application Macro.

Selecting an Application: Applications may be loaded during power-up by pressing and holding the STOP button, or by setting P1 from the Parameters menu. 1=Speed Control; 2=Manual/Auto; 3=Preset Speeds; 4=Raise/Lower; 5=PI Control; 9=Custom (650V only)

Terminal Assignments: Different applications require different setup parameters, inputs and outputs. When an application is selected, the 650 internally reassigns its control terminals for the relevant functionality. Also, depending on the application selected, an enhanced application-specific set of parameters will be visible, in addition to the regular parameters.

	SPEEDCONTROL P1=1	MANUAL/AUTO P1=2	PRESET SPEEDS P1=3	RAISE/LOWER P1=4	PI CONTROL P1=5
App-Specific Parameters	None	IP23 ANIN2 type OP21 DIGIO2 OP31 Relay	IP301 Preset 1 IP302 Preset 2 IP303 Preset 3 IP304 Preset 4 IP305 Preset 5 IP306 Preset 6 IP307 Preset 7 IP308 Preset 8	P401 Ramp Time P402 Max Value P403 Min Value P404 Reset Value	P501 Prop. Gain P502 Integral Gain
Control Terminal Assign	1 Common 0V 2 Speed In (V) 3 Speed In (mA) 4 +10V Supply 5 Speed Output 6 +24V Supply 7 Start button 8 Fwd/Rev 9 Jog 10 Stop button	1 Common 0V 2 Manual Ref (V) 3 Auto Ref (mA) 4 +10V Supply 5 Speed Output 6 +24V Supply 7 Manual Start 8 Auto Start 9 Man/Auto 10 Fwd/Rev	1 Common 0V 2 Speed In (V) 3 Speed In (mA) 4 +10V Supply 5 Speed Output 6 +24V Supply 7 Start 8 Preset Digital 1 9 Preset Digital 2 10 Preset Digital 3	1 Common 0V 2 Unused 3 Unused 4 +10V Supply 5 Speed Output 6 +24V Supply 7 Start 8 Raise Input 9 Lower Input 10 Ramp Reset	1 Common 0V 2 Reference (V) 3 Feedback (mA) 4 +10V Supply 5 Speed Output 6 +24V Supply 7 Start button 8 Fwd/Rev 9 Jog 10 Stop button

650V AND AUTOTUNE*

*for model 650V only. Autotune will not activate if in V/Hz mode.

For sensorless vector (SV) operation, an autotune is highly recommended, preferably with the motor uncoupled and free to rotate. (if the motor cannot be uncoupled, set CL20=0. See below).

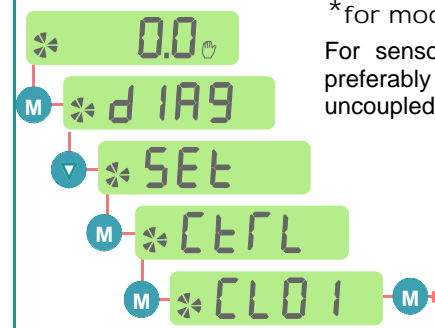

CONTROL PARAMETERS

CL01	Control Mode	0 = V/Hz; 1 = Sensorless Vector (SV)
CL02	Nameplate RPM	Enter RPM from motor nameplate
CL10	Motor Current	Enter full load amps from motor nameplate
CL11	Motor Poles	2=3600rpm; 4=1800rpm; 6=1200rpm
CL12	Motor Voltage	Enter motor nameplate voltage
CL20	Autotune Mode	0=stationary; 1=rotating (preferred)
CL21	Autotune Enable	set to 1 and run the drive to autotune
CL81	Current Limit	Current Limit setting as a % of CL10