

## VIEW LEVELS

There are three View Levels to the menu  
**Operator** – A very simple level. No setup allowed  
**Basic** – Default mode of the menu. Allows quick setup, save, restore and full diagnostics  
**Advanced** – Allows full access to the comprehensive set of function blocks in the Setup menu and more choices in the System menu to choose Language defaults and more  
View Levels may be selected from the Quick Setup menu, under View Level

## MACROS

The 690+ comes packaged with several Macros, which are preconfigured schemes. Current macros include  
**Basic speed control** - Load this to return to factory default parameters  
**Raise/Lower** – Pushbutton ramp using increase/decrease inputs  
**PID** – Provides closed loop process control  
**SPW** – Speed program winder (closed loop trim)  
**PRESET SPEEDS** – Provides 8 preset speeds  
To load a Macro, go to SYSTEM\RESTORE CONFIG and select the macro you wish to load

## INTERNAL LINKS

Under SETUP\LINKS, you may connect and disconnect internal block diagram connections, to use special functions like PID, winder blocks, diameter block, etc., and to tag analog and digital I/O to selected points inside the drive to suit your application needs. Specify sources and destinations to 50 internal links.

## TECHNOLOGY BOXES

The 6053 series of Technology boxes is available to communicate with protocols such as DeviceNet, PROFibus, ModBus, RS485 serial comms, CAN bus and LON works. These are fitted in place of the keypad. If the keypad is required, it can still be used with a remote mounting kit 6052.



Networking a standard 690+ to *LINK* is done with the *LINK* techbox. This has a built-in processor that can be configured using DSD, the *LINK* configuration software.

### Associated Literature

690+ Installation Manual HA465492Uxxx  
690+ Software Manual HA465038Uxxx



# 690+ Quick Start



**Flux Vector**  
**Sensorless Vector**  
**Volts/Hertz**

**frame B**  
**1 - 10 HP**  
**0.75-6 kW**

Visit us at [www.SSDdrives.com](http://www.SSDdrives.com)  
USA: (704) 588-3246 UK: +44 (0)1903 737000  
HA470631U100 Issue 5



## BEFORE YOU START

This document covers the steps necessary for a basic start up of the 690+ drive. Drive start ups should be performed by qualified electrical technicians who are familiar with AC drives and their applications. For detailed installation and safety information refer to the Installation Manual. For advanced features and applications, refer to the Software Manual.

Ensure that all local electric codes are met while installing the drive. Check that all live parts are covered to protect against electric shock and that unexpected rotation of the motor will not result in bodily harm or injury.

This document expects that the drive is already installed in its intended location and that all relevant installation procedures have been followed. Please ensure that the drive has adequate ventilation so that ambient temperature does not exceed 45°C (112°F) under normal operating conditions.

To access the terminals, loosen the two retaining screws at the bottom of the drive, pull up gently on the terminal cover, and slide it off.

## CONTROL MODES

The 690+ supports 3 different control modes

**Volts/Hertz** mode – Most basic open loop operation, used in fans/pumps and multi-motor applications. No options needed

**Sensorless Vector** mode – Tight speed regulation with good transient torque capability, without the need for speed feedback. No options needed

**Flux Vector** mode – Precise flux vector control with full torque down to zero speed and improved dynamic performance. Optional Speed Feedback Technology Card required on the drive and an encoder on the motor

## POWER CONNECTIONS

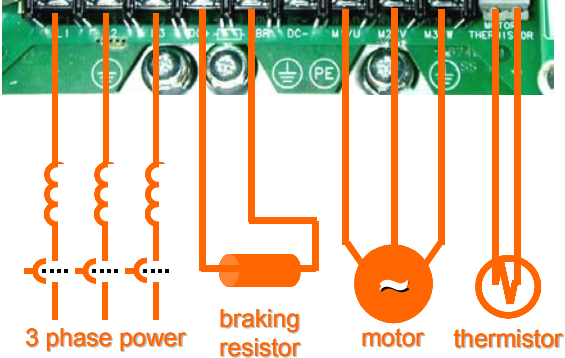
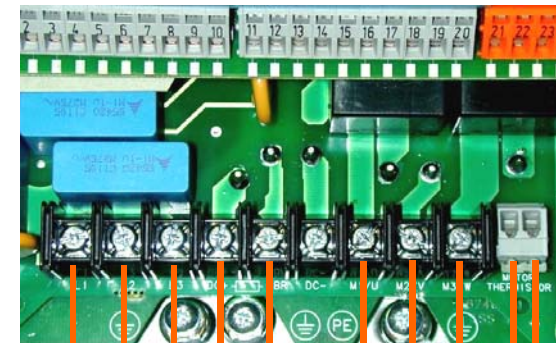

- 3-phase supply to L1, L2, L3. On single phase units use L1, L2/N
- Motor connections to M1, M2, M3
- Brake resistor between DC+, DBR
- Motor thermistor to Motor Thermistor
- Common Bus to DC+, DC-

Ground lugs have been provided for each of the power circuits. Follow proper grounding and shielding methods as described in chapter 3 of the Installation Manual.

The frame B has a built-in braking module. If the stop time is expected to be less than the natural coasting time of the load, connect a braking resistor across DC+ and DBR.

## REFERENCE

## SEQUENCING

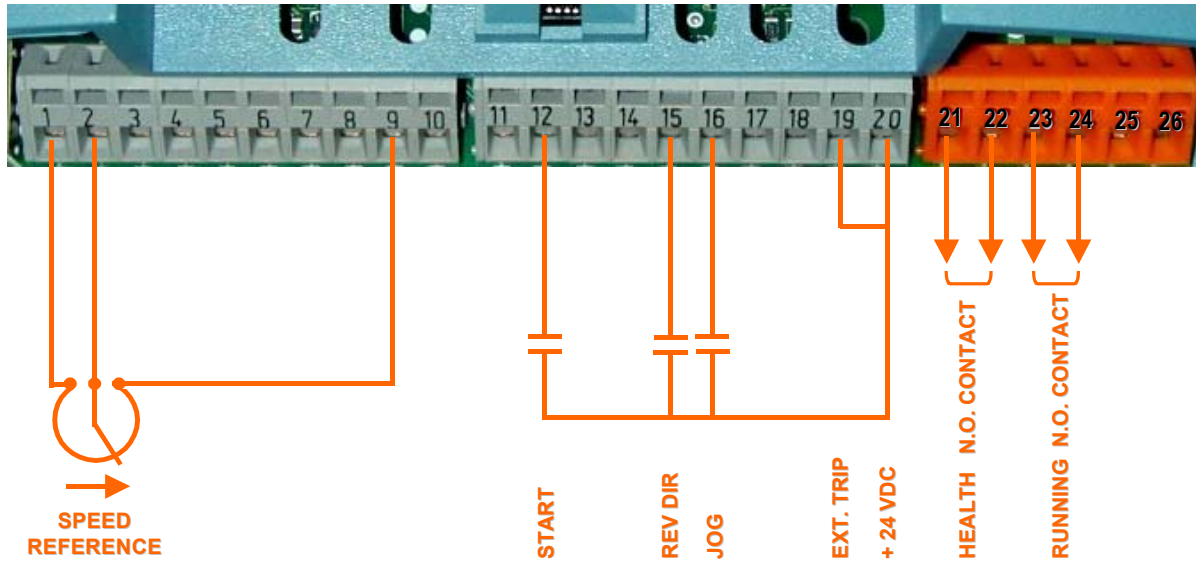

- Speed potentiometer across 1(low), 9 (high), 2(wiper) OR
- External 2-wire speed reference between 1(-) and 2(+)

- Jumper 19 and 20 if no external trip contact
- Start contact between 12 and 20
- Jog contact between 16 and 20
- Reverse Direction contact between 15 and 20
- Health volt-free contacts between 21 and 22
- Running volt-free contacts between 23 and 24

## SPEED FEEDBACK

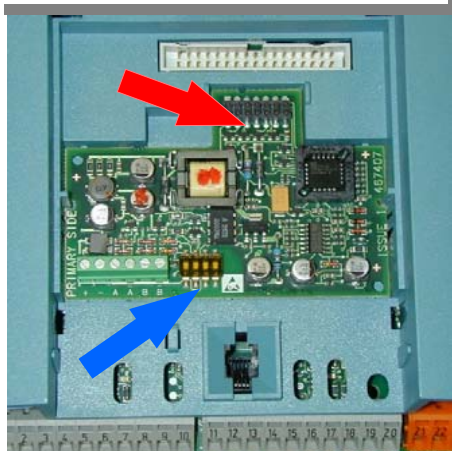

- The Speed Feedback Card is required only for closed loop Flux Vector Control

**CAUTION**  
Static Sensitive Board. Install only with power OFF and follow proper static/grounding procedures

- Install it on the feedback header, shown by the red arrow in the figure. Ensure a good fit by securely snapping in place
- DIP switches 1,2,3,4 (blue arrow) set the threshold voltage of the encoder signals. Set all switches to ON (up position) for complementary encoder signals
- Encoder connections to terminal block are:
  - 1 Encoder Supply positive (5–15VDC)
  - 2 Encoder Supply negative (0V)
  - 3 Channel A
  - 4 Channel A complement
  - 5 Channel B
  - 6 Channel B complement

## CALIBRATION

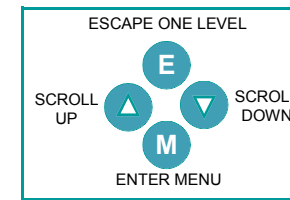

All calibration is done in software, through the keypad

The 690+ can also be calibrated using the programming tool software

AC MOTOR DRIVE  
4.0KW 400V 1.3

M OPERATOR  
Menu at Level 1

DOWN DIAGNOSTICS  
Menu at Level 1

DOWN QUICK SETUP  
Menu at Level 1

M

This is the power-up welcome screen. If a different screen appears, press E a few times to return to this screen

Press the M key to get to OPERATOR LEVEL

DOWN arrow to get to the DIAGNOSTICS menu

DOWN arrow to get to the QUICK SETUP menu

Press M to enter QUICK SETUP and set parameters relevant to the operating mode of the drive by scrolling UP or DOWN

The following is a list of the relevant parameters that you may need to check before starting the drive. Several of these may not need adjustment if you are running a standard 60Hz, 460V 1800 RPM induction motor

			V/Hz	SV	Vector
1	Control Mode	Select the intended operating mode	x	x	x
2	Max Speed	Set max speed in RPM	x	x	x
3	Min Speed	Set min speed in %	x	x	x
4	V/Hz shape	Choose fan only for square curve	x		
5	Motor Current	Motor full load current	x	x	x
6	Motor Base Freq	Motor nameplate frequency	x	x	x
7	Motor Voltage	Motor nameplate voltage	x	x	x
8	Nameplate RPM	Motor nameplate RPM	x	x	x
9	Motor Poles	for 1800rpm=4, for 1200rpm=6	x	x	x
10	Encoder Supply	set between 5-15V to match encoder			x
11	Encoder Lines	Pulses per Revolution of encoder			x
12	Encoder Invert	Changes polarity of encoder feedback			x
13	Autotune Enable	Drive will Autotune if started		x	x

## AUTOTUNE

- In the QUICK SETUP menu, set AUTOTUNE ENABLE to TRUE
- MAX SPEED should be greater than NAMEPLATE RPM for a successful autotune
- On the keypad press L/R for LOCAL mode
- Ensure that the motor is uncoupled and free to rotate without causing problems
- Press RUN. Drive will begin autotuning, The drive will stop without errors if autotune is successful
- Go to SYSTEM/SAVE CONFIG/APPLICATION and UP arrow to save your settings

### Note

In V/Hz mode, Autotune is not necessary and will not activate

POWER ON