

590+ Dynamic Brake Contactor Option



Application

The 590+ DRV frames 1 and 2 are equipped with an AC (line-side) contactor. For dynamic braking applications, you will need a braking resistor and this kit to connect the resistor across the motor terminals. Use the following table to specify the contactor kit and resistor appropriate for the power rating of your drive and motor. This combination, in accordance with Nema ICS 3-302.62, will provide 150% instantaneous braking torque from base speed for each power range, with 2 times motor inertia and 3 stops per hour.

460VAC

HP	Contactor kit	Resistor kit
1	955+DBC35	CZ353134
2	955+DBC35	CZ353134
3	955+DBC35	CZ353134
5	955+DBC35	CZ353135
7.5	955+DBC35	CZ353136
10	955+DBC35	CZ353137
15	955+DBC35	CZ353138
20	955+DBC35	CZ353139
25	955+DBC70	CZ353140
30	955+DBC70	CZ353140
40	955+DBC70	CZ353142
50	955+DBC110	CZ353142
60	955+DBC110	CZ353144
75	955+DBC162	CZ353145
100	955+DBC162	CZ353146

This contactor kit includes

- DIN rail mounted dynamic braking contactor
- Zero Speed interlock relay mounted to the contactor
- Instruction sheet

- Mount the DIN rail in close proximity to the drive and snap on the contactor
- Wiring diagram and ladder logic shown on the following page

230VAC

HP	Contactor kit	Resistor kit
1	955+DBC35	CZ353159
2	955+DBC35	CZ353159
3	955+DBC35	CZ353159
5	955+DBC35	CZ353160
7.5	955+DBC35	CZ353161
10	955+DBC35	CZ353162
15	955+DBC70	CZ353163
20	955+DBC70	CZ353164
25	955+DBC110	CZ353164
30	955+DBC110	CZ353166
40	955+DBC162	CZ353167
50	955+DBC162	CZ353167

IMPORTANT

For dynamic braking to be effective, the motor field needs to stay energized for the duration of the stop, even after the drive has been disabled. Under **SETUP PARAMETERS \ FIELD CONTROL**, set **FLD. QUENCH DELAY** to 20 seconds

Recommended Wire Sizes

Power wiring (Rated > 500V)	A1 to contactor to resistor to A2	12 AWG for the 955+DBC35 10 AWG for the 955+DBC70 8 AWG for the 955+DBC110 1 AWG for the 955+DBC162
120VAC Control	Drive L, N to contactor coil	16 AWG red
24VDC Control	Drive to zero speed relay coil	18 AWG blue
Signal wiring	Drive enable to contactor	18 AWG blue

590+ Dynamic Brake Contactor Option

Connection Diagram

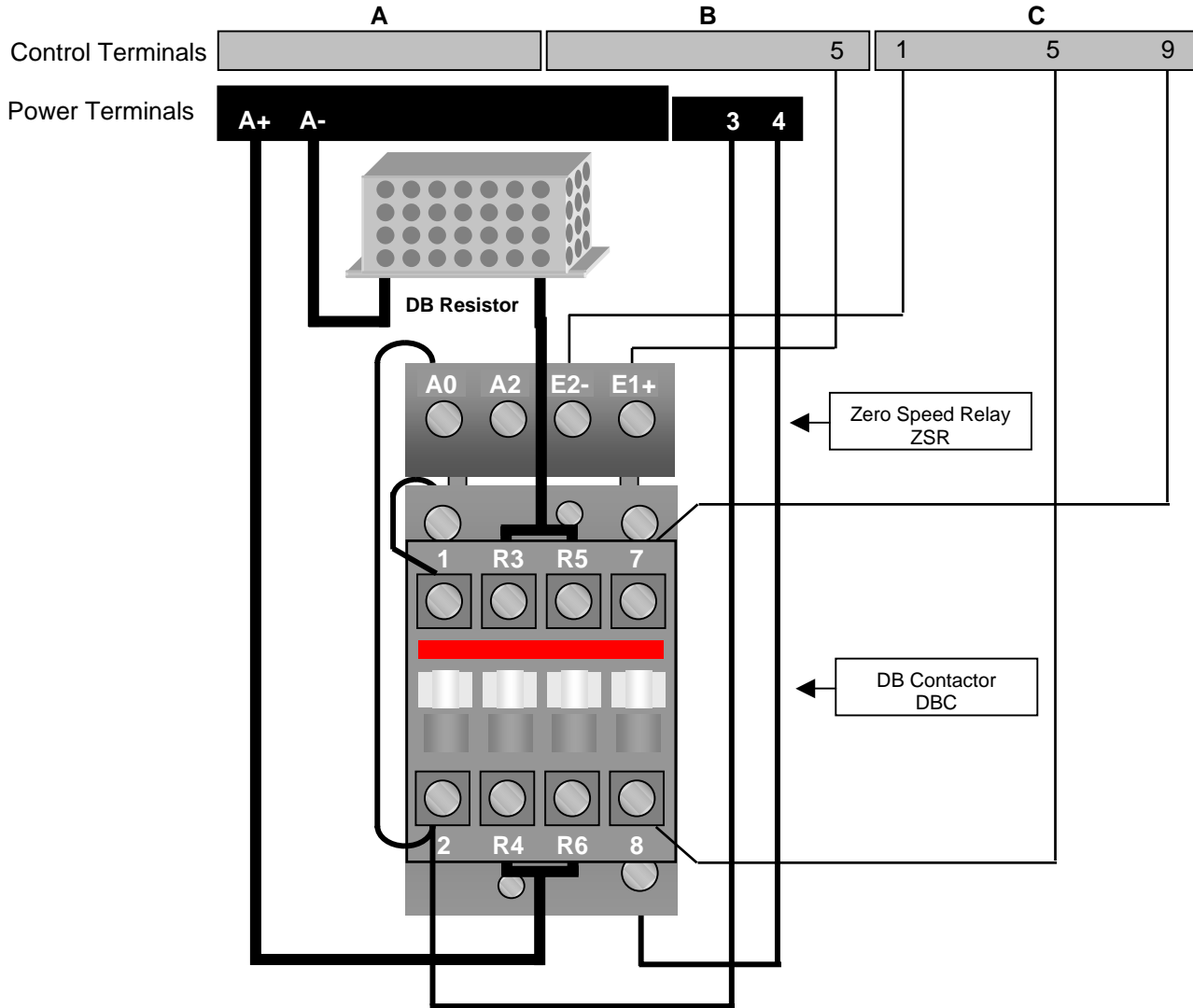

Ladder Logic

