

TS8000



Link RTN Option
8000/LK/00
HA470411U001 Issue 1

© Copyright SSD Drives, Inc. 2005

All rights strictly reserved. No part of this document may be stored in a retrieval system, or transmitted in any form or by any means to persons not employed by an SSD Drives company without written permission from SSD Drives, Inc.

Although every effort has been taken to ensure the accuracy of this document it may be necessary, without notice, to make amendments or correct omissions. SSD Drives cannot accept responsibility for damage, injury, or expenses resulting there from.

Companies, names and data used as examples herein are fictitious unless otherwise stated. All trademarks and copyrights are acknowledged as the property of their respective owners.

Table of Contents

Product Overview	3
General Description	3
Safety Information.....	4
Contents Of Package	4
Specifications	5
Power Requirements	5
Serial Communications	5
Fiber Optic Communications	5
Installation Instructions	7
Hardware Diagnostics	9
Module LED Status	9
Network LED Status.....	9
Diagnostic Codes.....	10
Software Configuration.....	11
Configuring The Link System	11
Configuring The TS8000 HMI	13

Product Overview

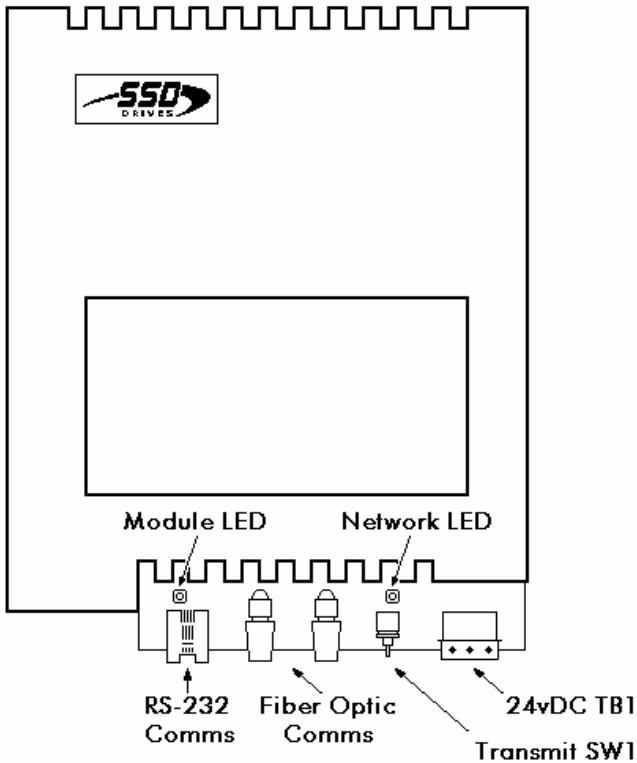

- **Configured with DSD software.**
- **Noise-free fiber optic interface** to any other devices on the high speed Link network. RS-232 serial comms interface to the TS8000 HMI.
- **24vDC powered** by an external supply.
- **DIN rail** mountable for ease of use.
- **Installation and connection hardware** included with card.

General Description

The 8000/LK/00 option card provides a high speed interface (2.7Mbit) between the TS8000 series HMI and a Link fiber optic network. This module is similar to a 6055/LINK TechBox, but can be mounted on standard DIN rail instead of being plugged into a drive.

The option card has two fiber optic terminals that accept 1000 micron acrylic fiber. The transmit strength over the Link network can be adjusted via a 3-position toggle switch. In addition, the option card also provides a standard RJ-style serial jack for connection to a TS8000 HMI.

The 8000/LK/00 requires the use of an external 24vDC power supply connected to terminal block TB1.

Safety Information

All safety related regulations, local codes and instructions that appear in the manual or on equipment must be observed to ensure personal safety and to prevent damage to either the instrument or equipment connected to it. If equipment is used in a manner not specified by the manufacturer, the protection provided by the equipment may be impaired.

Do not use the controller to directly command motors, valves, or other process actuators not equipped with safeguards. To do so can be potentially harmful to persons or equipment in the event of a fault to the controller.

Contents Of Package

The option card will come shipped with the following additional equipment:

- 8000/LK/00 option card.
- Hardware mounting packet.

Specifications

The following specifications pertain to the TS8000 series option cards. SSD Drives retains the right to modify specifications at any time, without prior notice.

Power Requirements

Power is supplied to the option card from an external 24vDC supply connected to terminal block TB1 (200mA rated inrush, 65mA steady state).

Serial Communications

Cable Type: SSD Drives part number CM471054 (Standard TS8000 Comms).

Fiber Optic Communications

Fiber Type: SSD Drives part number CM056316U030.

- Core Diameter: 1000 micron.
- Cable Type: Acrylic.
- Bending Radius: > 1 inch (25.4 mm).
- Insulation: Vinyl > 1kV.

Transmit Strength Settings: Switch SW1.

- Center Position: Low intensity – 0-20 m transmit range (0-66 ft).
- Up Position: Medium intensity – 21-40 m transmit range (67-132 ft).
- Down Position: High intensity – 41-60 m transmit range (133-196 ft).

Installation Instructions

The following specifications pertain to the TS8000 series option cards. SSD Drives retains the right to modify specifications at any time, without prior notice.

To install the option card, remove all power and I/O communication cables from the unit.

Snap the 8000/LK/00 onto a standard DIN rail.

Connect the RS-232 cable from the option card to the RS-232 Comms port of the TS8000.

Connect the Receive Fiber into the black connector and the Transmit Fiber into the blue connector. The fiber optic loop should be closed with the Link network as shown below:

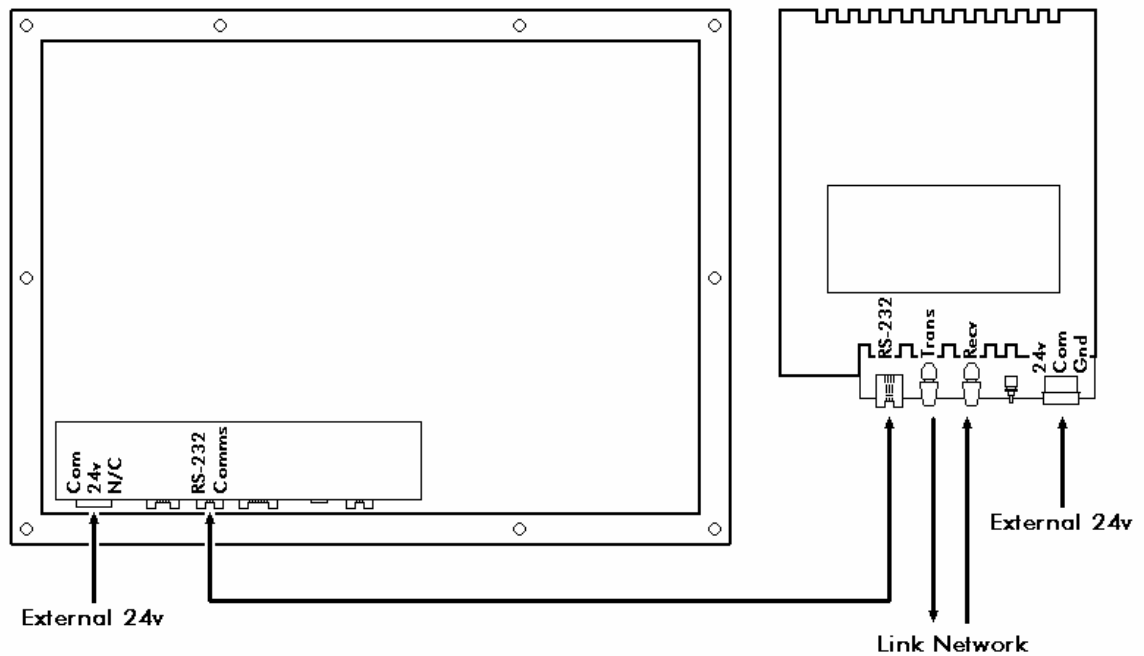

Connect external 24v DC power to both the TS8000 and the 8000/LK/00.

Hardware Diagnostics

Module LED Status

The Module LED (left side) indicates the configuration state of the 8000/LK/00.

LED State	Fault	Description
Off	No Power	* External 24v DC power not applied
Slow Flash (2 flash/sec)	Initialization Fault	* Self test failure * Module does not have a valid config
Fast Flash (4 flash/sec)	Off Link Network	* Module was halted by Link * Module is attempting to go online * Config problem (L-Error, H-Error, or duplicate address)
On	None	* Module config is running and communicating over the Link network

Network LED Status

The Network LED (right side) indicates the status of the connected Link network.

LED State	Fault	Description
Off	Faulted	* Network failure * Module halted or initializing
On	None	* Network healthy * Module peer halted or duplicate address

Note: The Network LED can only be in the On state when the Module LED is On continuously, indicating that the 8000/LK/00 is ready for external communications.

Diagnostic Codes

The Module LED (left side) indicates the configuration state of the 8000/LK/00.

NCP State	Module State	Module LED	Network LED
0	Initializing	Slow Flash	Off
1	Config	Fast Flash	Off
2	Fault	Slow Flash	See note
3	Fault	Fast Flash	See note
4	Fault	Fast Flash	See note
5	Fault	Slow Flash	See note
6	Stopping	---	---
7	Running	On	On
8	Running	On	On
9	Running	On	Off
A	Starting	Fast Flash	See note
B	Starting	Fast Flash	On
C	Fault	Fast Flash	On

Note: LED state depends on whether the network is active at this node's receiver..

Software Configuration

This document describes the necessary steps to configure the TS8000 HMI to communicate RS-232 to a Link network using SSD Drives RTNx protocol. This document is intended for those users who have a working knowledge of both the DSD and DSI8000 software packages.

To implement this system, the TS8000 requires a device to act as its gateway to the Link network. That gateway can either be a 6053/LINK or 6055/LINK TechBox, or it can be a L5300 Link Rack. This application will use a TS8008 connected serially to a 6055/LINK TechBox as its gateway (Node 400). The Link network will consist of: the aforementioned 6055/LINK, an L5300 Link Rack (Node 500), and a 690+ AC Drive with a 6055/LINK TechBox (Node 10). This topology is diagrammed as follows:

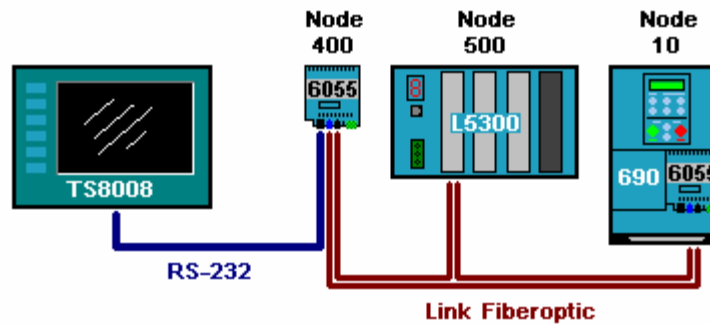

For more information on the 605x/LINK TechBox refer to: HA470016 – LINK TechBox Instruction Manual, and for the L5300 refer to: HA353952 – LINK Rack Installation Manual.

Configuring The Link System

Programming the Link system requires the use of DSD version 1.21 or later and the Link Database Class Revision must be at 1238 or greater. Earlier DSD versions do not have the required files to support communications with the TS8000 HMI. To program the application, begin a new project with the following Link Templates:

- TS8000TB – this will be the TS8000 gateway (Node 400).
- L5300 – this will be a standard Link2 Rack (Node 500).
- L690Pv5 – this will be a 690+ AC Drive with a Link TechBox (Node 10).

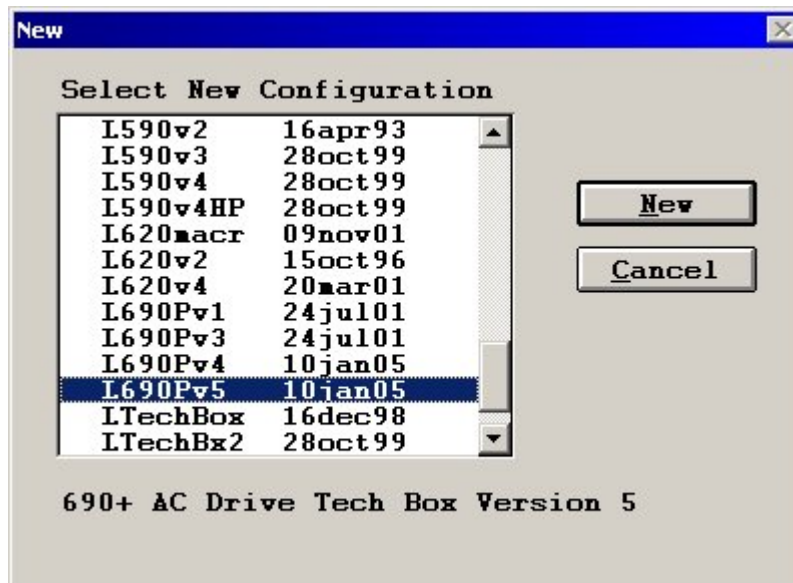
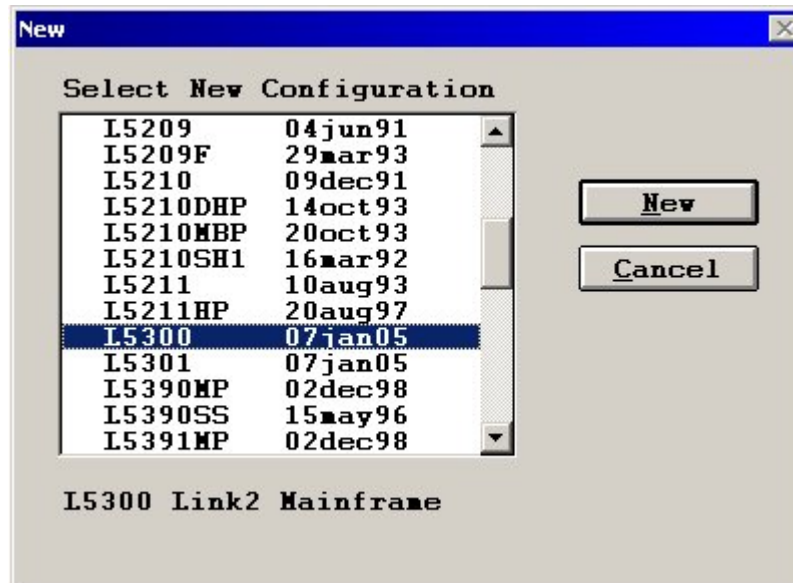
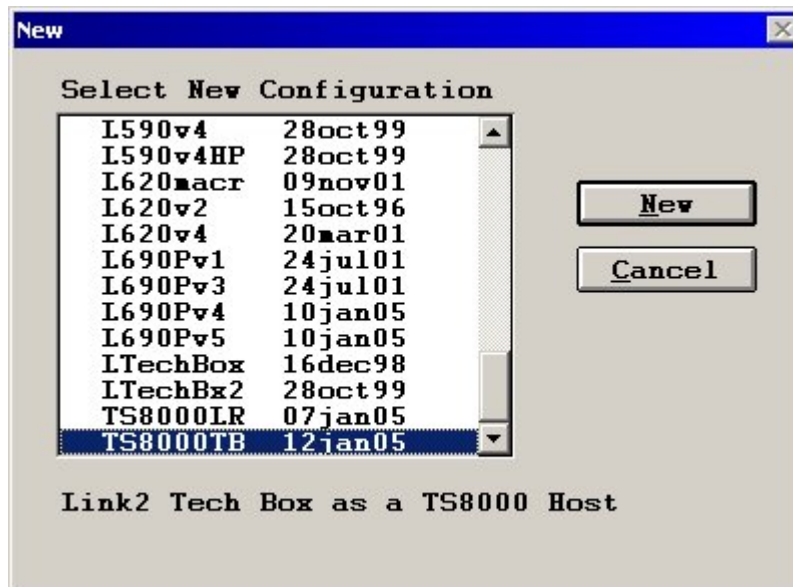

Configuring The TS8000 HMI

1. Configure the Communications.

- Navigate to the Communications section of DSI8000.
- Select the RS-232 Comms Port by selecting it from the tree on the left.
- Select the SSD Drives 890-RTNx driver from the applet at the right.

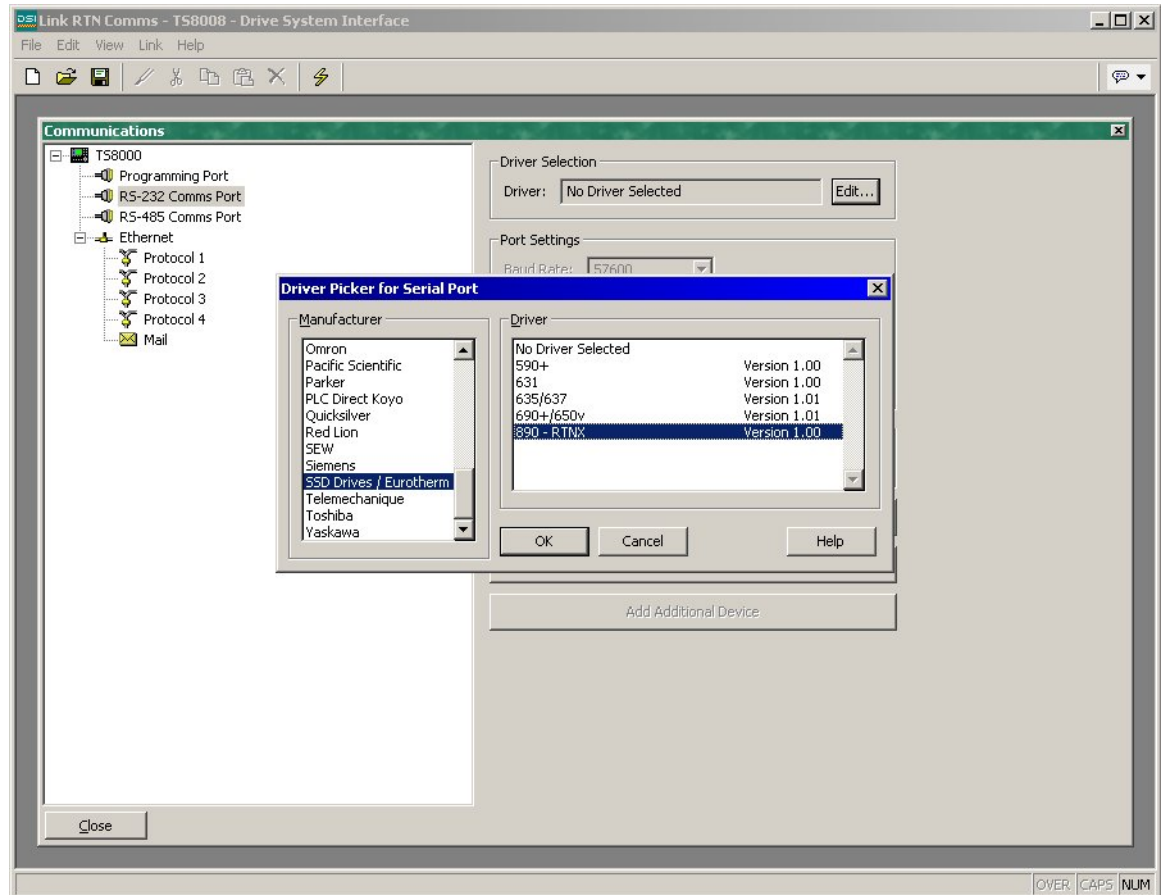

- Use the Add Additional Device button to create two more devices for the Link rack and the 690.
- Name each device as appropriate, and set each Destination Node field as defined above in the Link configuration.

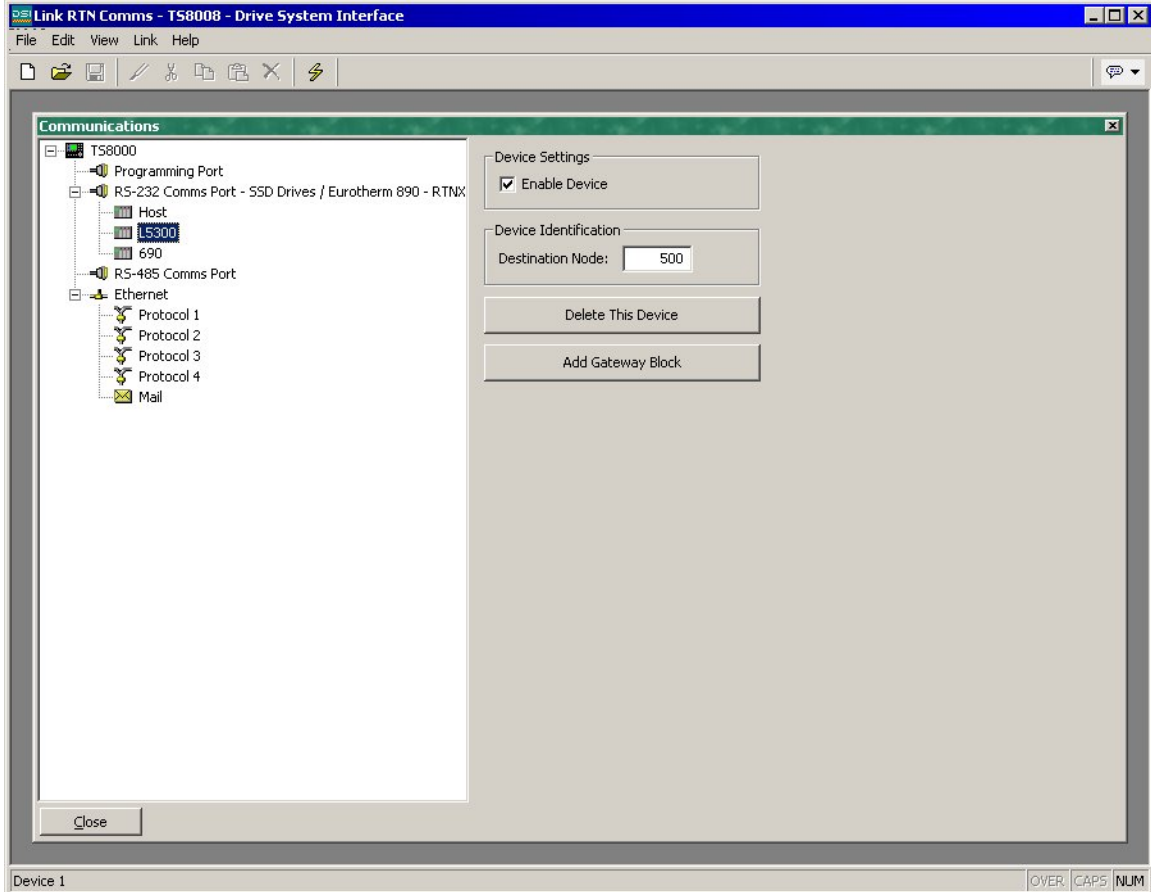
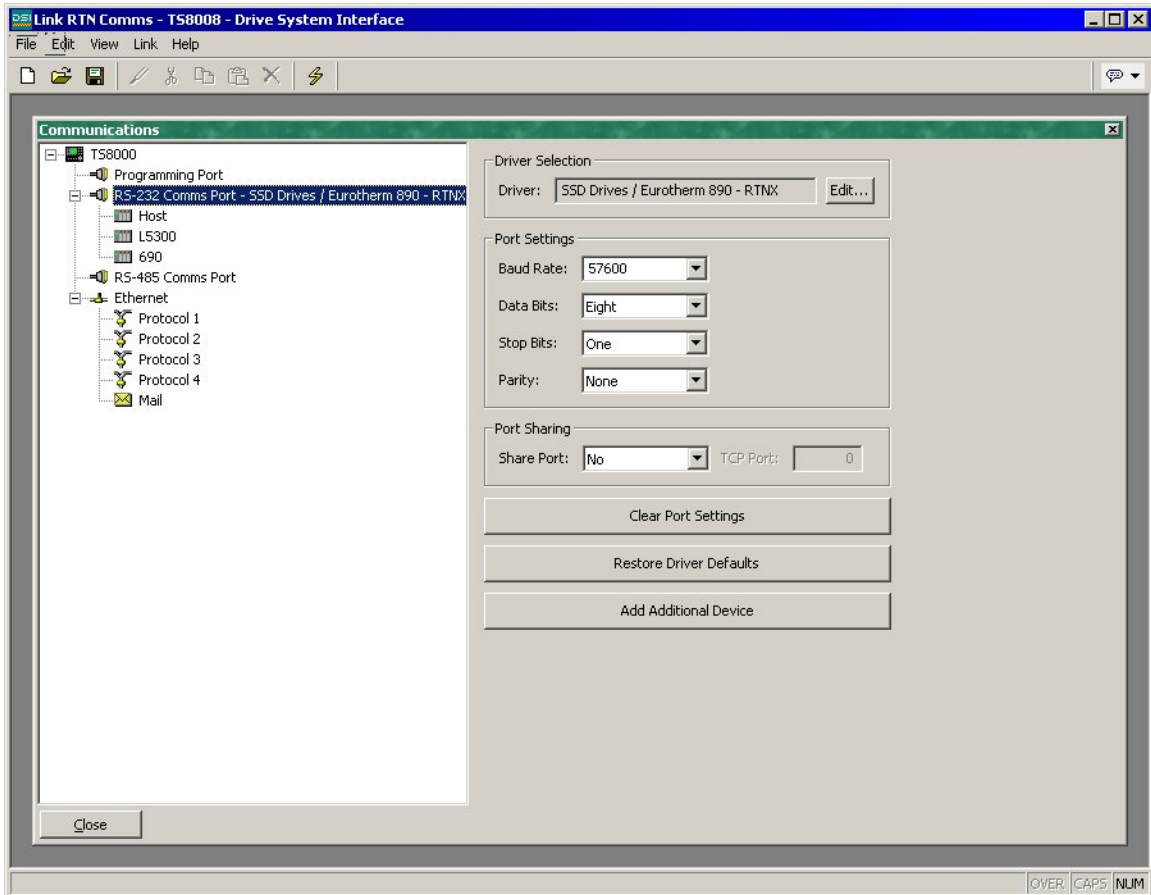

2. Addressing Link data.

At this point it is important to discuss how data is transferred in a Link network. All Link data is handled in a "Write-Forward" approach. This means that data must be sent from the source node to the destination node. Link nodes are not capable of requesting data to read. The TS8000 HMI does not specifically follow this approach. The TS8000 is capable of reading data as well as writing it. In addition, from the TS8000's perspective, inbound slot numbers must be less than 1024. Because of this combined architecture, data exchange with the TS8000 will be handled as follows:

How The TS8000 Writes Data To Link – Data going from the TS8000 may be written to ANY device on the Link network. The individual TS8000 data tag uses the destination device mapping to specify exactly which node is being written to.

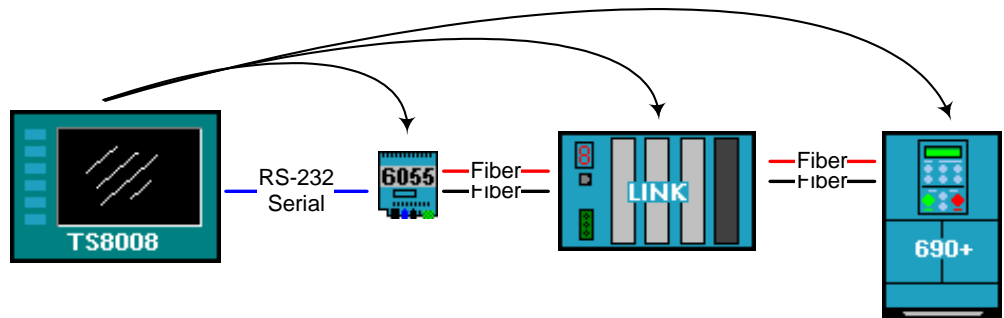

How The TS8000 Reads Data From Link – Data going to the TS8000 may only be written to the HOST device on the Link network. The TS8000 data tag uses the source device mapping of the Host to specify exactly where the data is coming from.

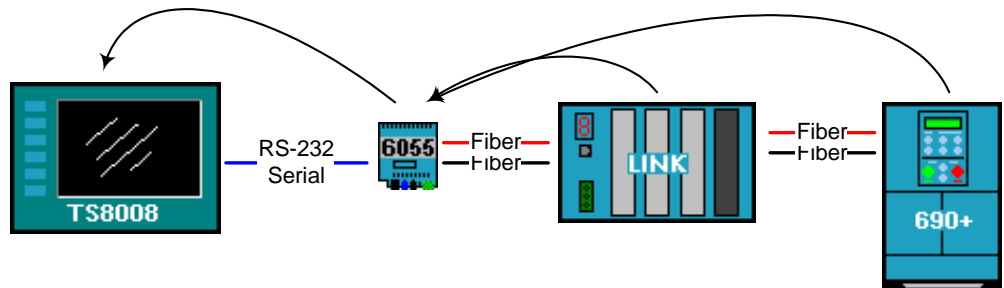

TS8000 Write Only Tags – Data from the TS8000 may be written to ANY device on the Link network. In our sample application, this means that the TS8000 may directly write data to the Host TechBox (Node 400), the L5300 (Node 500), and the 690 Drive (Node 10). This write data will be available at the destination node through a pre-defined Input Slot with the appropriate Slot Number. The example below shows both the TS8000 data tag and the Link Input Slot to send a value to the L5300 (Node 500) at slot 1:

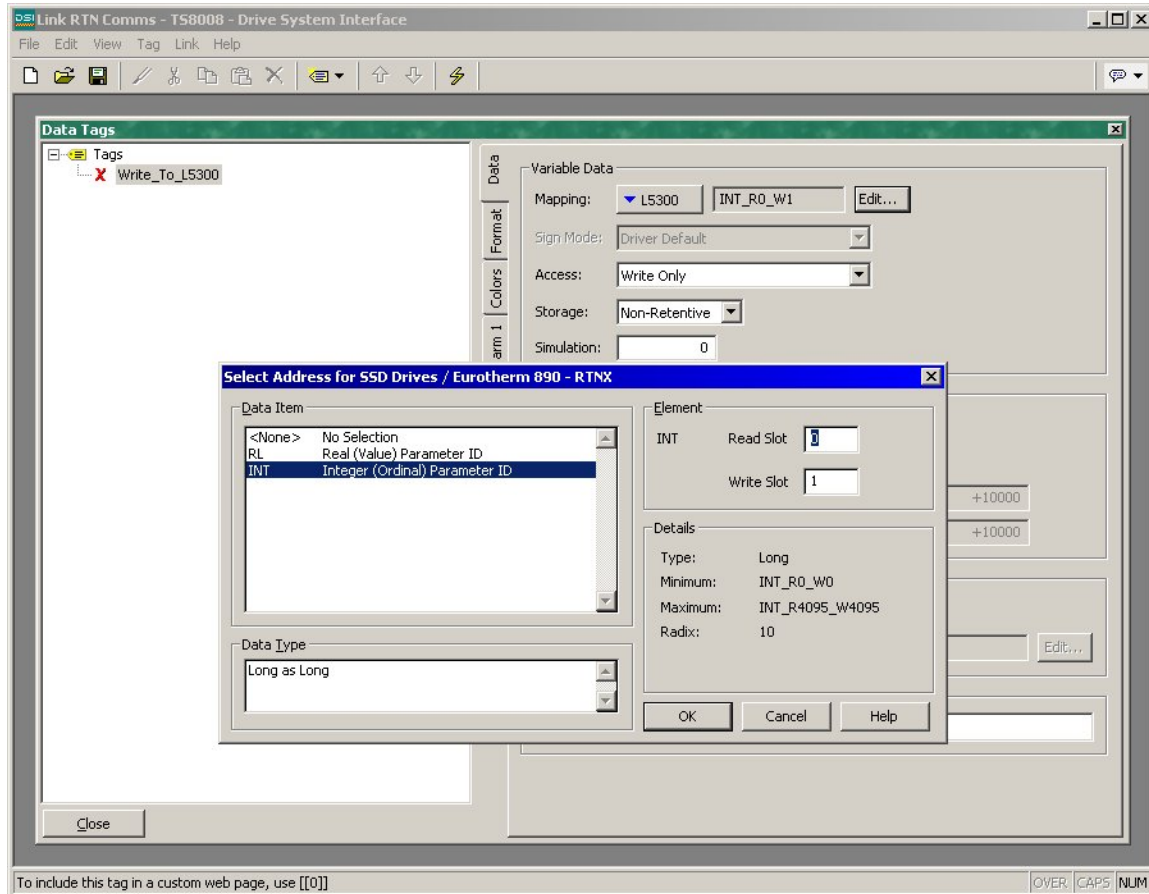

The Write Only tag uses the L5300 (Node 500) device mapping, since that is the destination device for the data. It specifies Write Slot 1, since that will be the incoming data slot that we will program at the L5300.

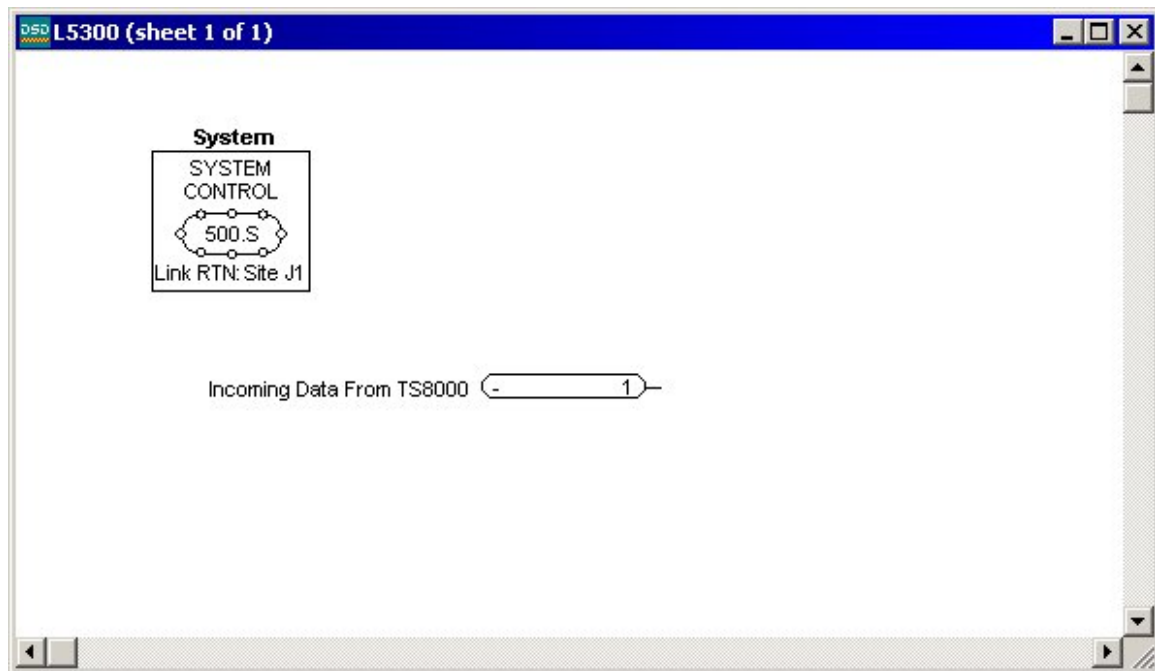

The L5300 is programmed with the Incoming Slot to receive the data from the TS8000. This data is passed from the TS8000 via the Host TechBox (Node 400) to the L5300 (Node 500). This data is now available to use as needed in the Link application.

TS8000 Read Only Tags – Data from the TS8000 may be read ONLY from the Host TechBox (the node you are serially plugged into). Because of this, all read data must be previously WRITTEN to the Host TechBox from the source node. This read data will be available from the same pre-defined Output Slot number that was used to send it to the Host TechBox. In our sample application, this means that the TS8000 may directly read data from the Host TechBox (Node 400). The example below shows both the Link Output Slot and the TS8000 data tag to send a value from the L5300 (Node 500) to slot 2 of the Host TechBox (Node 400):

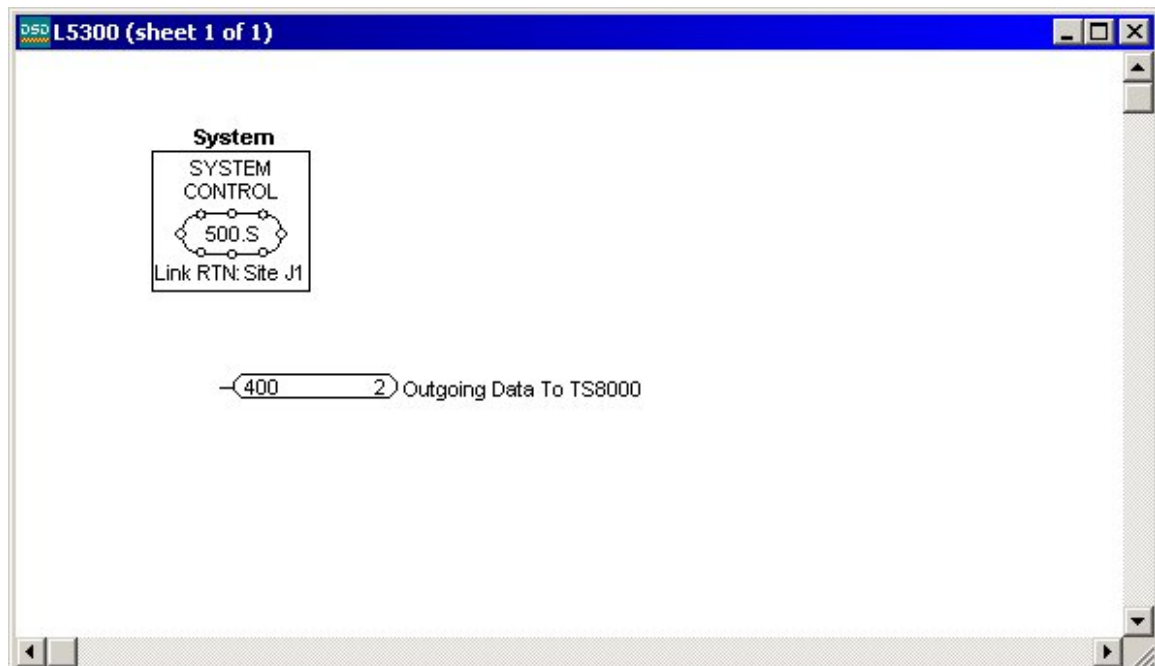

The L5300 is programmed with the Outgoing Slot to send data to the TS8000. This data is sent to the Host TechBox (Node 400) and then read serially by the TS8000. You do not have to explicitly define an Input Slot in the Host TechBox for this data.

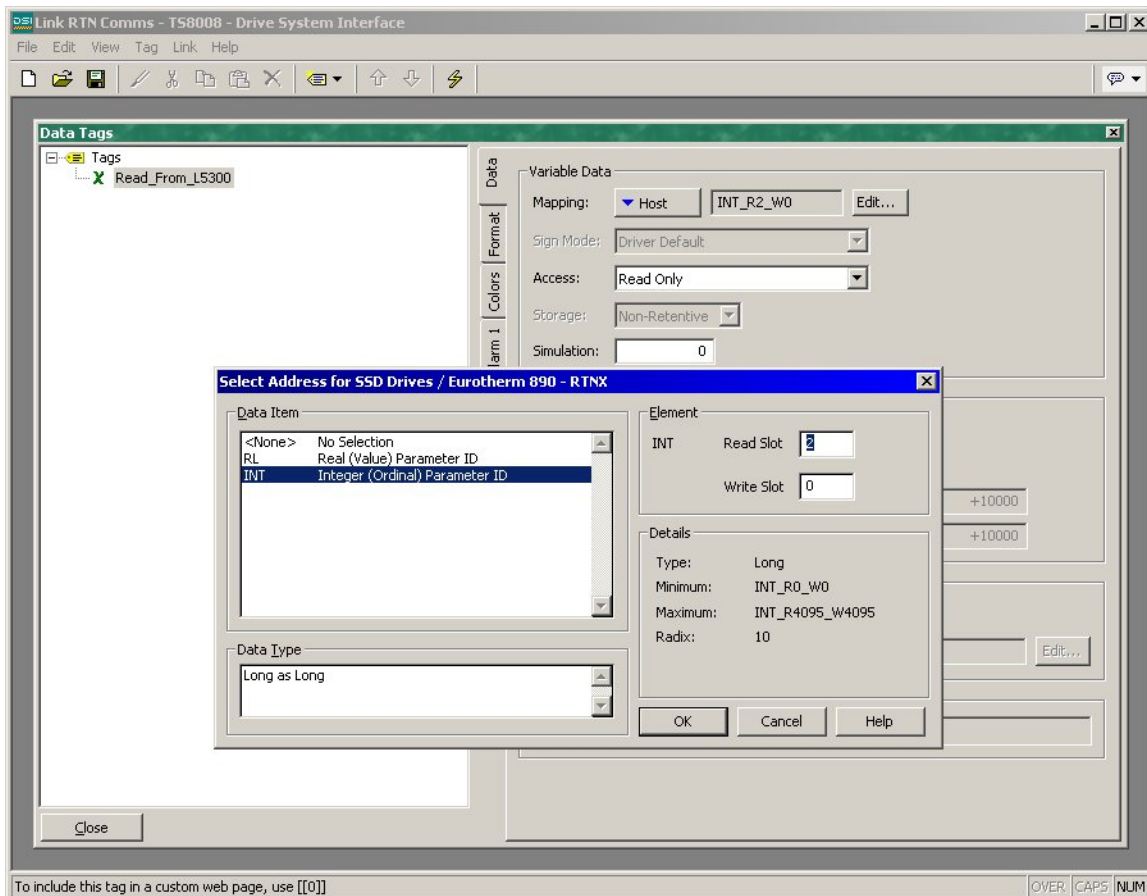

The Read Only tag uses the Host (Node 400) device mapping, since that is the source device for the data. It specifies Read Slot 2, since that is the outgoing data slot that was programmed at the L5300.

TS8000 Read / Write Tags – TS8000 data is written to the destination L5300 (Node 500), and read from the Host TechBox (Node 400). At the Link level, the data exchange follows both of the methods described above, and therefore requires an Input Slot mapping and an Output Slot mapping. The example below shows both the Link Input and Output Slots and the TS8000 data tag to read and write a value with the L5300 (Node 500):

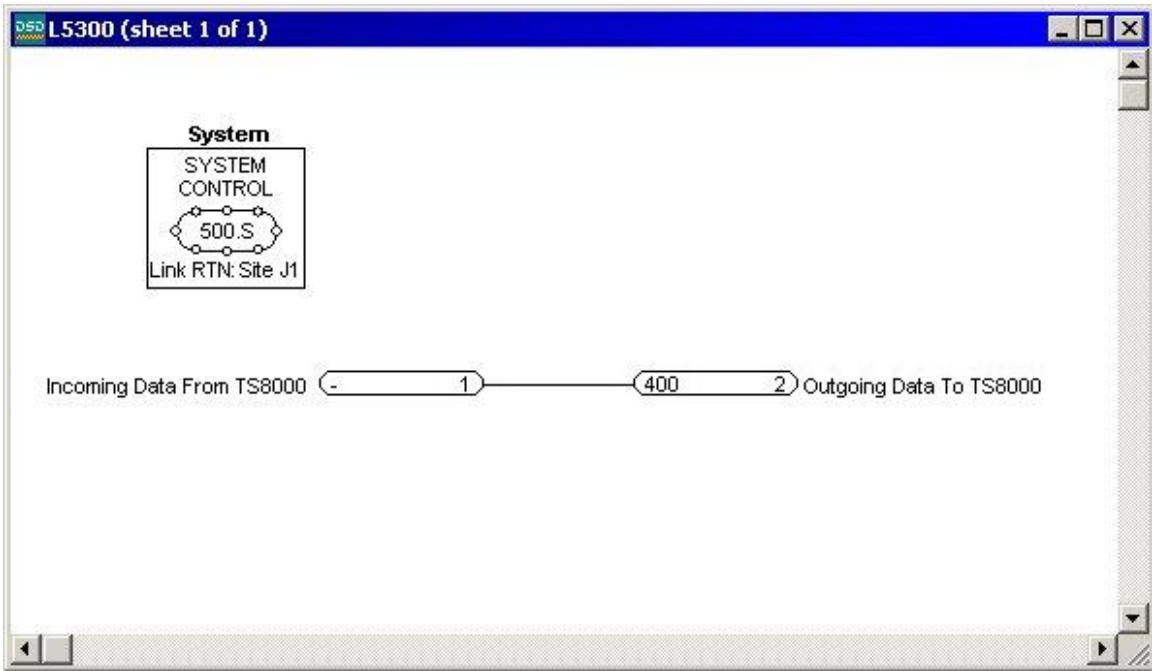

The L5300 is programmed with the Incoming and Outgoing Slots to send and receive data to and from the TS8000.

The screenshot displays the "Link RTN Comms - TS8008 - Drive System Interface" software. The "Data Tags" window shows a tag named "ReadWrite_L5300". The configuration for this tag includes:

- Mapping: L5300 INT_R2_W1
- Sign Mode: Driver Default
- Access: Read and Write
- Storage: Non-Retentive
- Simulation: 0

 A dialog box titled "Select Address for SSD Drives / Eurotherm 890 - RTNX" is open, showing:

- Data Item: INT Integer (Ordinal) Parameter ID
- Data Type: Long as Long
- Element: INT with Read Slot 2 and Write Slot 1
- Details: Type: Long, Minimum: INT_R0_W0, Maximum: INT_R4095_W4095, Radix: 10

The Read Write tag uses the L5300 (Node 500) device mapping, since that is the destination device for the data. It specifies both Write Slot 1 and Read Slot 2, since those are the data slots that were programmed at the L5300. Keep in mind that in this scenario, reads are ALWAYS implied to be from the Host node.

3. Data Scaling and Type.

Link data may be presented in one of three styles:

Logic Data – is data that represents a two-state value (0 or 1, True or False, On or Off). Logic data is represented as a full 16-bit word even though the state only uses the first bit of the word. In the TS8000, Logic data is represented with the Flag data type. Flags in the TS8000 must read the status of the entire data word before they can execute a write to a single bit. This is because the TS8000 must preserve the state of the remaining 15 bits of the word. This means that Write Flags in the TS8000 must be Read/Write Flags to work properly. When using a TS8000 Flag to represent Logic Link data, no additional scaling transforms are required.

Ordinal Data – is 16-bit unsigned word data that ranges between 0-65535. In the TS8000, Ordinal data is represented with the Integer data type. When using a TS8000 Integer to represent Ordinal Link data, no additional scaling transforms are required.

Value Data – these are normalized numbers that are represented as percentage of 32767. This means that value data with a range of -100.00 to 100.00 translates to a range of -32767 to 32767. In the TS8000, Value data may be represented with either the Real data type, or the Integer data type. When using a TS8000 Real to represent Value Link data, no additional scaling transforms are required. However, if a TS8000 Integer is used to represent a Value Link data, additional scaling transforms will be required. In the example below, the TS8000 Integer, ValueAsInteger, is used to represent a Link Value of -100.00 to 100.00. To properly scale this number, several configurations must be made:

- From the Data Tab, in the Scaling and Transforms section, Linear Scaling was selected as the Transform type.
- From the Data Tab, in the Scaling and Transforms section, the Store As fields (which represent the raw data coming from Link) were set to a minimum value of -32767 and a maximum value of 32767.
- From the Data Tab, in the Scaling and Transforms section, the Display As fields (which represent the scaled data in the TS8000) were set to a minimum value of -10000 and a maximum value of 10000.
- From the Format Tab, in the Data Limits section, the Minimum Value was set to -10000 and the Maximum Value was set to 10000.
- From the Format Tab, in the Data Format section, the Digits Before DP field was set to 3 and the Digits After DP field was set to 2. This action is responsible for formatting the scaled data to 2 decimal places.

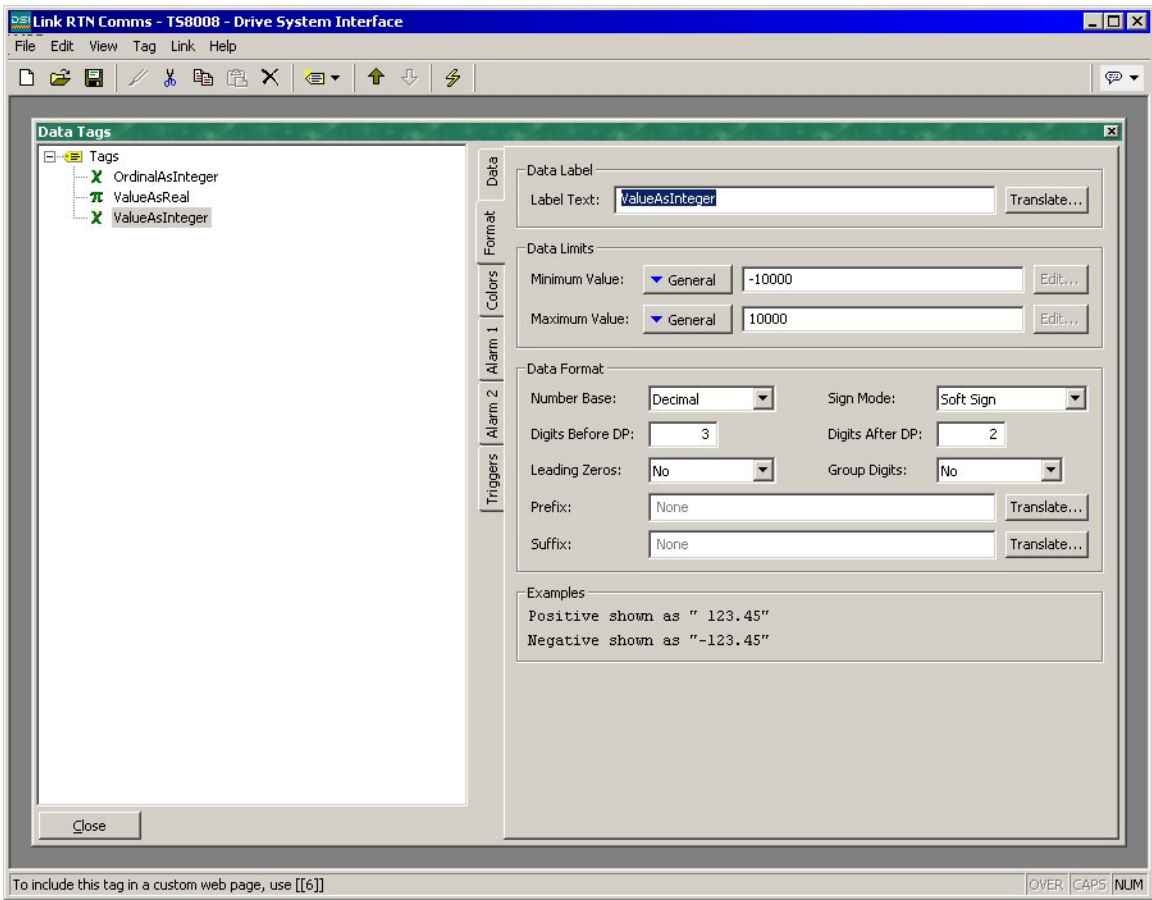
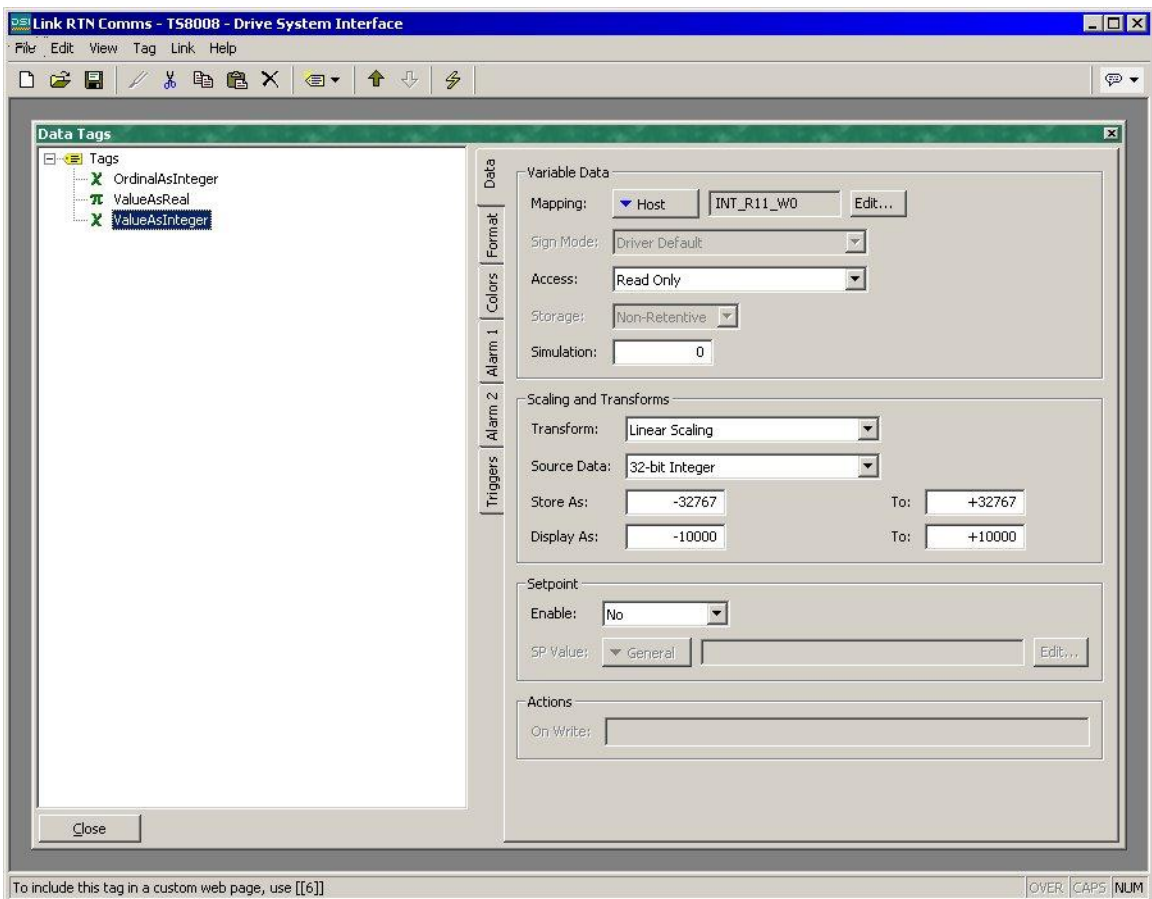

Limited Warranty

SSD Drives warrants the goods against defects in design, materials, and workmanship for the period of 12 months from the date of delivery on the terms detailed in SSD Drives Standard Conditions of Sale IA058393C.

SSD Drives reserves the right to change the content and product specification without notice.

UK
SSD Drives Ltd
New Courtwick Lane
Littlehampton
West Sussex BN17 7RZ
Tel: +44 (0)1903 737000
Fax: +44 (0)1903 737100

CANADA
SSD Drives Inc
880 Laurentian Drive
Burlington
Ontario L7N 3V6
Tel: +1 (905) 333 7787
Fax: +1 (905) 632 0107

CHINA
SSD Drives Ltd
Room 1603, Hua Teng Edifice
302# Jin Song San Qu
Chaoyang District,
Beijing 100021
P.R. China

DENMARK
SSD Drives AB
Enghavevej 11
DK-7100
Vejle
Tel: +45 (0)70 201311
Fax: +45 (0)70 201312

FRANCE
SSD Drives SAS
15 Avenue de Norvège
Villebon sur Yvette
F-91953 Courtaboeuf Cedex
Paris
Tel: +33 - 1 69 18 51 51
Fax: +33 - 1 69 18 51 59

GERMANY
SSD Drives GmbH
Von-Humboldt-Strasse 10
64646 Heppenheim
Tel: +49 (6252) 798200
Fax: +49 (6252) 798205

ITALY
SSD Drives SPA
Via Gran Sasso 9
20030 Lentate Sul Seveso
Milano
Tel: +39 (0362) 557308
Fax: +39 (0362) 557312

SWEDEN
SSD Drives AB
Montörgaten 7, SE-302 60
Halmstad
Tel: +46 (0)35-17 73 00
Fax: +46 (0)35-10 84 07

U.S.A.
SSD Drives Inc
9225 Forsyth Park Drive
Charlotte
North Carolina 28273
Tel: +1 (704) 588 3246
Fax: +1 (704) 588 3249

01/11/04

Local availability and service support also in:

ARGENTINA • AUSTRALIA • AUSTRIA • BELGIUM • BRAZIL • CHILE • CHINA • COLOMBIA • CYPRUS
CZECH REPUBLIC • EGYPT • GREECE • HONG KONG • HUNGARY • ICELAND • INDONESIA • IRAN
IRELAND • ISRAEL • JAPAN • KENYA • KOREA • LITHUANIA • MALAYSIA • MOROCCO • NETHERLANDS
NEW ZEALAND • NORWAY • PHILIPPINES • POLAND • PORTUGAL • ROMANIA • SINGAPORE • SOUTH AFRICA
SPAIN • SWITZERLAND • TAIWAN • THAILAND • TURKEY • UNITED ARAB EMIRATES

Local Address

www.SSDdrives.com



TS8000 Link RTN Option Card