



EUROTHERM
DRIVES

DeviceNet Communications Interface

Technical Manual

HA463575U002 Issue 1

Compatible with Version 2.x Software

© Copyright Eurotherm Drives Limited 2001

All rights strictly reserved. No part of this document may be stored in a retrieval system, or transmitted in any form or by any means to persons not employed by a Eurotherm group company without written permission from Eurotherm Drives Ltd.

Although every of this document it may be necessary, without notice, to make amendments or correct omissions. Eurotherm Drives cannot accept responsibility for damage, injury, or expenses resulting therefrom.

DeviceNet™

Eurotherm Drives' DeviceNet products comply with the Device Net Specification. Vendor Identification Number is 45.

Safety Information



Please read this information BEFORE installing the equipment.

Intended Users

This manual is to be made available to all persons who are required to install, configure or service equipment described herein, or any other associated operation.

The information given is intended to highlight safety issues, and to enable the user to obtain maximum benefit from the equipment.

Application Area

The equipment described is intended for industrial motor speed control.

Personnel

Installation, operation and maintenance of the equipment should be carried out by qualified personnel. A qualified person is someone who is technically competent and familiar with all safety information and established safety practices; with the installation process, operation and maintenance of this equipment; and with all the hazards involved.

REFER TO YOUR MAIN PRODUCT MANUAL FOR SPECIFIC SAFETY INFORMATION ABOUT THE DEVICE YOU ARE CONTROLLING

Contents

Contents

Page

DEVICENET COMMUNICATIONS INTERFACE	7
A System Overview	7
The DeviceNet Protocol.....	7
Principles of Operation.....	8
I/O Data Exchange.....	8
Product Features.....	9
Product Code and Contents.....	9
Installation	9
Wiring the System.....	9
Cable Specification.....	10
Earthing the Shield.....	10
User Connections to the DeviceNet Technology Option.....	11
Terminators.....	11
Terminal Block (TB1) Connections.....	11
Fitting and Connecting to the Technology Box.....	12
Wiring Diagram Example.....	13
Initial Check for Connection.....	13
Understanding the LED Indications.....	13
Module LED Indications.....	14
Network LED Indications.....	14
Initial Set-up for DeviceNet	15
Configuring the Drive.....	15
Configuring the PLC/SCADA Supervisor.....	18
Configuration Tools.....	19
Explicit Messaging.....	19
Polled I/O Connection.....	31
Cyclic Connection.....	46
Example Configurations	47
Installing an EDS file into DeviceNet Manager.....	47
Installing an EDS file into RsNetWorx for DeviceNet.....	48
Configuring a Drive using the Operator Station.....	50
Configuring the drive's block diagram.....	50
Configuring DeviceNet Manager.....	51
Placing a 590+ Drive on to the Network.....	51
Connecting a Drive to a Scanner.....	52
Configuring RsNetWorx for DeviceNet.....	57
Placing a 590+ Drive on to the Network.....	57
Connecting a Drive to a Scanner.....	58
Fault Detection.....	61
590+.....	61
690+.....	62
Troubleshooting	64
LED Indicators.....	64
Module LED.....	64
Network LED.....	65
Internal Diagnostics.....	66
TEC OPTION FAULT.....	66
DEVICE STATUS.....	67
CONNXXN STATUS.....	68
Decimal/Hexadecimal Table.....	69

DEVICENET COMMUNICATIONS INTERFACE

A System Overview

DeviceNet™ is a low-level network that provides connections between simple industrial devices, such as sensors, actuators, motor controllers as well as higher level devices. DeviceNet serves to transport control information and other information, such as configurations, to and from low-level devices.

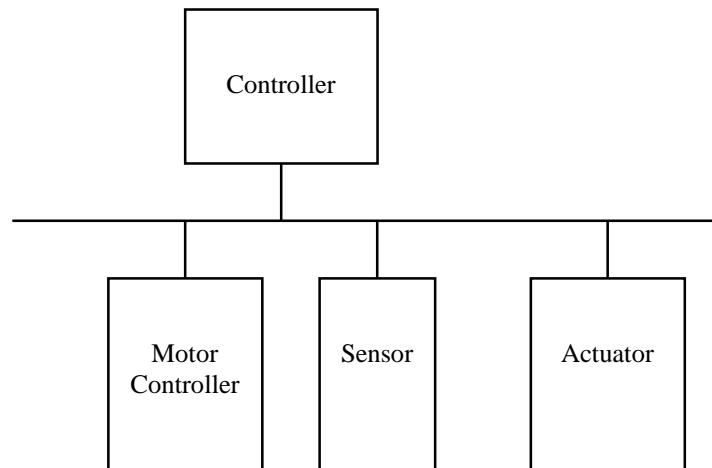

Figure 1 DeviceNet Application Areas

The DeviceNet Option supports the group 2 only slave subset of the DeviceNet protocol. It is most often used to allow a central Programmable Logic Controller or PC based control system to use external 'slave' devices for I/O or specialised functions. The principal advantage is that these devices may be distributed around a machine, thereby saving on the cost of point to point wiring. The 'open' nature of the network also permits equipment from different manufacturers to be mixed on the same bus. Additionally, the off-loading of complex and specialised tasks such as PID temperature control lessens the processing load on the central PLC so that its other functions may be carried out more efficiently and requires less CPU memory.

The DeviceNet Protocol

DeviceNet is a vendor independent, open fieldbus standard for a wide range of applications in manufacturing, process and building automation. Vendor independence and openness are guaranteed by the DeviceNet standard and by product approval through the Open DeviceNet Vendor Association (ODVA). With DeviceNet, devices from different manufacturers can inter-communicate. Suitable interfaces exist for PLCs, such as those manufactured by Allen Bradley, Toshiba and others.

The DeviceNet network uses the Controller Area Network (CAN) physical layer, and operates at baud rates up to 500kbaud. A table of network speed against segment length is given on page 10. The DeviceNet standard provides for devices to be self-powered, or powered from the DeviceNet network.

A maximum of 64 DeviceNet stations (nodes) may be contained within a single network.

DeviceNet is a multimaster, multislave network. A device gains access to the network by a non-destructive collision detection mechanism. More detailed information, including a detailed guide to products available, may be obtained from the various world-wide DeviceNet user organisations. You will find contact information in trade magazines or by reference to <http://www.odva.org> on the World Wide Web.

Principles of Operation

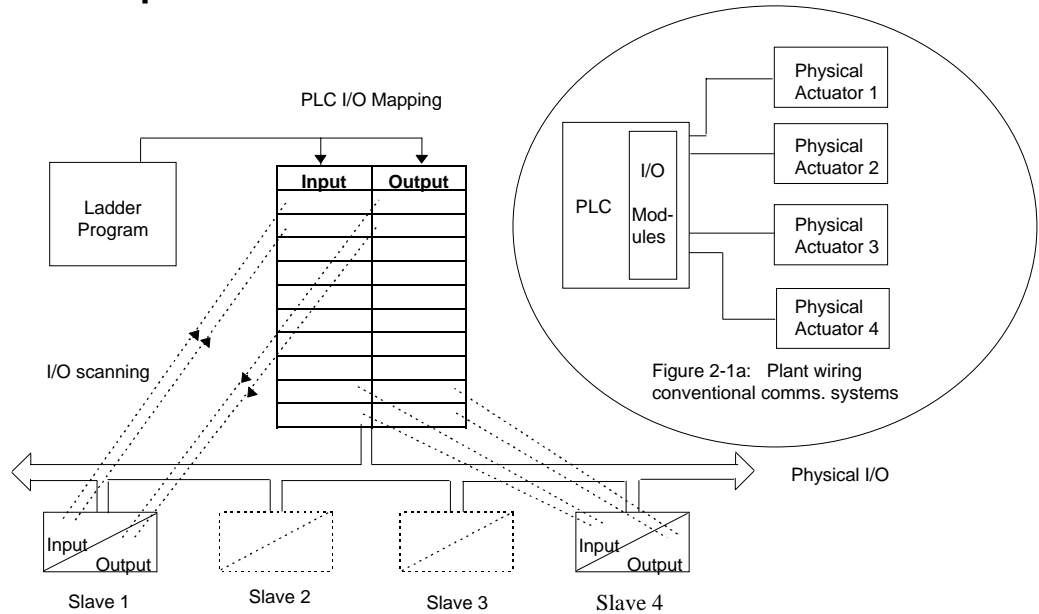

Figure 2 DeviceNet compared with conventional comms. systems

DeviceNet supports both master - slave and peer to peer communications. It allows slave devices to be connected on a single bus, thus eliminating considerable plant wiring typical with conventional communications systems. The Figure above compares the two systems.

I/O Data Exchange

The process of reading inputs into a PLC for example, and writing to its outputs is known as an I/O data exchange. Typically, the parameters from each slave device will be mapped to an area of PLC memory.

A device asserts data onto the network using a collision detection mechanism. Both master and slave devices can initiate a transmission:

1. Wait until the network is quiet.
2. Start to transmit. The first part of a transmission is an arbitration field. If another device starts to transmit at the same time, arbitration takes place, and the losing device will immediately terminate its transmission and retry later. This mechanism is transparent to the user. Arbitration does not affect the device that wins arbitration, its transmission is not corrupted and continues normally.

The arbitration scheme gives priority to the device with the lowest node address in preference to those with higher node addresses. This should be considered when assigning node addresses to devices on the network.

The input and output data mixture used by a given slave device is defined in an electronic data sheet, also known as an EDS file. This file is available from Eurotherm Drives.

Product Features

- Suitable for use with:
 - 584SV software version 4.x onwards
 - 605A & B software version 4.x onwards
 - 605C software version 4.x onwards
 - 590+ software version 5.x onwards
 - 690+, all software versions
- Connection using shielded, twisted-pair cable
- LEDs to indicate board and communications status
- Configured using Function Block inputs
- Diagnostics using Function Block outputs
- Software-selectable Node Address (Machine Access Control ID, or MAC ID)
- Supports DeviceNet drive profiles
- Supports DeviceNet Group 2 Only Slave communications

Product Code and Contents

The Eurotherm Drives' product is fully identified using an alphanumeric code which records how the product was assembled, and its various settings when despatched from the factory.

The Technology Option can be supplied with the drive product, or supplied separately:

Product	Product Code when supplied with the Drive	Product Code when supplied separately
584SV	584SV /xxxx/xxx/xxxx/xx/xxx/ DNET /xx/xxx/xxx	LA463610U004
590+	590P /xxxx/xxx/xxxx/xx/xxx/ DNET /xxx/xxx	6055/DNET/00 - plug-in Technology Box
591P	591P /xxxx/xxx/xxxx/xx/xxx/ DNET /xxx/xxx	6055/DNET/00 - plug-in Technology Box
605A & B	605 /xxx/xxx/x/x/xxx 5 /xx/xxx	6053/DNET/00 - plug-in Technology Box
605C-F	605C /xxxx/xxx/xxxx/xx/xxx/ DNET /xx/xxx/xxx	6055/DNET/00 - plug-in Technology Box
690+B	690PB /xxxx/xxx/x/x/xxxx/xxxx/xxxx/ DNET /xxxx/xxxx/xxxx	6053/DNET/00 - plug-in Technology Box
690+C-E	690P /xxxx/xxx/xxxx/xx/xxx/ DNET /xxx/xxx/xx/xxx/xxx	6055/DNET/00 - plug-in Technology Box

Installation

Wiring the System

WARNING!

Before installing, ensure that the drive and all wiring is electrically isolated and cannot be made "live" unintentionally by other personnel.

Wait 5 minutes after disconnecting power before working on any part of the system or removing the covers from the Drive.

The DeviceNet Option is provided in a plug-in Technology Box suitable for installing in most Eurotherm Drives products (see the Product Code definition on page 9).

It is operated as a 4-wire system. Two wires convey the DeviceNet data, and the remaining two wires convey power if the product is to be remotely powered. Remote powering is recommended

and is necessary if the drive is ever to be powered down and the DeviceNet network is to remain operational between other devices.

Note: *It is possible to make serial communications operate without adhering to the following recommendations, however, the recommendations will promote greater reliability.*

Cable Specification

The DeviceNet specification makes recommendations for cable type depending on whether the cable is to serve in a trunk or a drop.

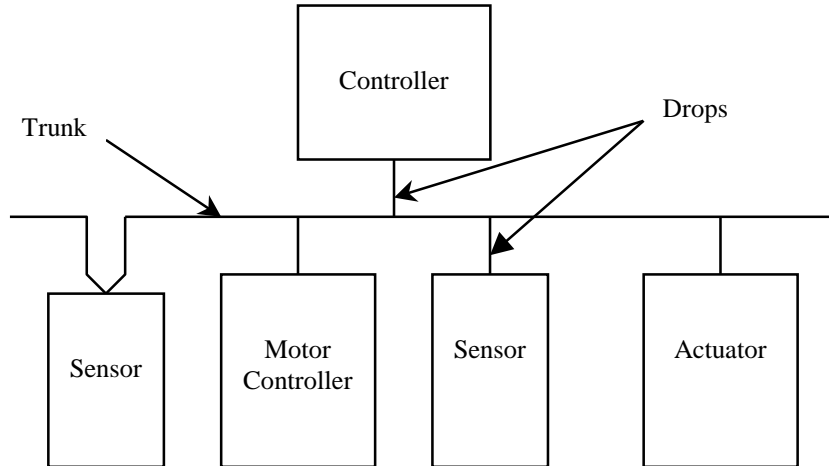

Full cable specifications are provided in the DeviceNet specification, Volume I appendix B. A summary is given here.

	Trunk cable	Drop cable
Signals wires	Twisted pair, #18. Blue / white	Twisted pair, #24. Blue / white
Power wires	Twisted pair, #15. Black / red	Twisted pair, #22. Black / red
Shield	Foil / braid with drain wire (#18); bare. Each pair shielded separately in aluminized mylar. Combined pair shielded	Foil / braid with drain wire (#22); bare. Signal pair shielded in foil. Overall braid shield
Internal insulation	PVC insulation on power pair	PVC insulation on power pair
Electrical	High speed (VP ≥ 0.75), low loss, low distortion data pair.	High speed (VP ≥ 0.75), low loss, low distortion data pair.
Characteristic impedance of data pair	120 Ω ± 10%	120 Ω ± 10%

Maximum Cable Lengths

The maximum cable length depends on the baud rate selected:

Data Rate	Trunk Distance	Drop Length	
		Maximum	Cumulative
125kbaud	500 metres (1600 ft.)	3 metres (10ft)	156 metres (512 ft.)
250kbaud	200 metres (600 ft.)		78 metres (256 ft.)
500kbaud	100 metres (300 ft.)		39 metres (128 ft.)

Earthing the Shield

The cable shield should be connected to each device on the network. Details for connections to Eurotherm Drives products are given on page 13.

User Connections to the DeviceNet Technology Option

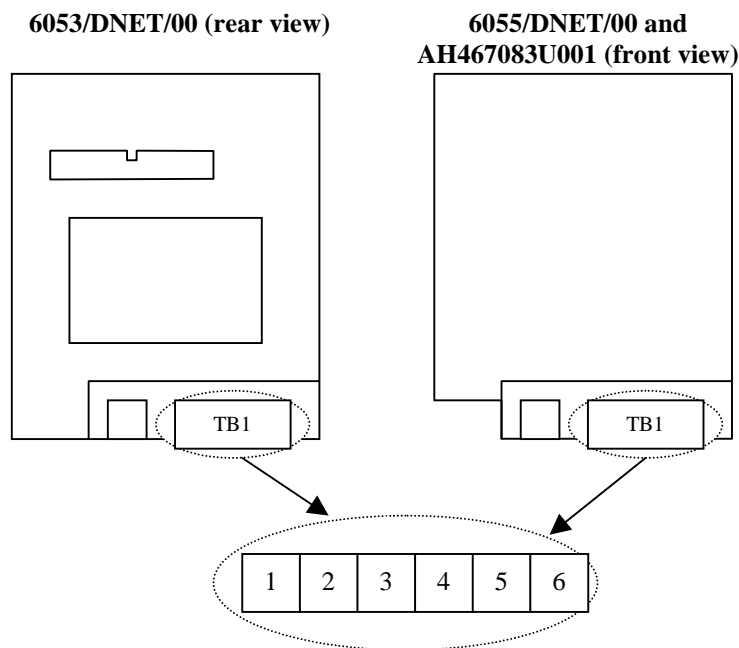

Figure 3 Option showing TB1

Note that if the 6053/DNET/00 is viewed from the front, i.e. with the DeviceNet label on top, the numbering of terminals is effectively reversed.

Terminators

- If the drive is at the end of the trunk it must have a terminating resistor.
- All other drives in the system should not have a terminator.

Connect terminating resistors to the last drive as shown opposite. (resistor is $\pm 1\%$, minimum $\frac{1}{4}$ Watt).

The DeviceNet specification recommends 121Ω , but it should be chosen to equal as closely as possible the characteristic impedance of the cable.

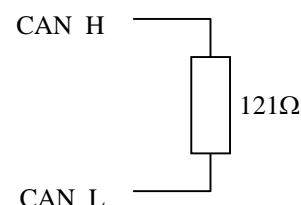

IMPORTANT: Failing to fit terminating resistors correctly may result in unreliable operation.

Terminal Block (TB1) Connections

TB1 Terminal	Reference	Meaning
1	0v	Return for +24v power supply input
2	CAN_L	Signal connection
3	SHIELD	For connecting cable screen
4	CAN_H	Signal connection
5	+24v	Power supply input. Current consumption is less than 25mA.
6	GND	Chassis Ground. On 605A & B only, connect this terminal to chassis ground via 1.5mm (min) wire.

Note: Terminals 1 to 5 inclusive conform to the DeviceNet recommended terminal assignment.

Fitting and Connecting to the Technology Box

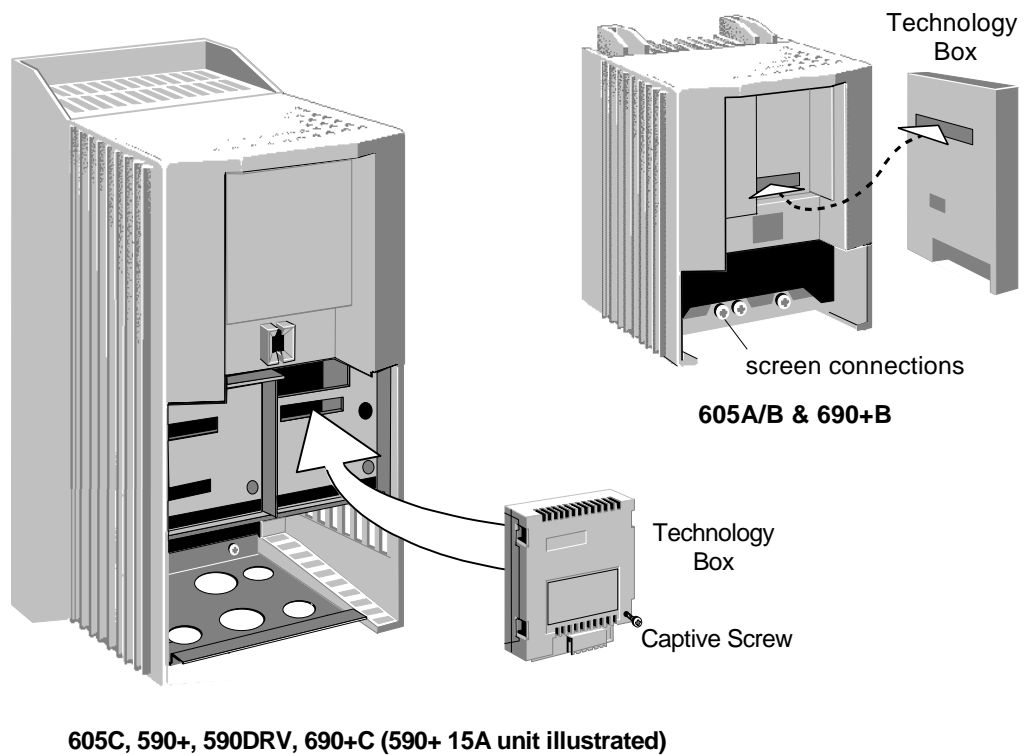

Figure 4 Plug-in Technology Boxes

WARNING!

Ensure that all wiring is isolated.

The Technology Option plugs into the right-hand position on the front of the drive, or in place of the Operator Station/blank cover (605A/B and 690+B only).

It can be used with the Operator Station fitted, but for the 605A/B and 690+B units you must mount the Operator Station remotely using the Panel Mounting Kit with connecting lead (6052/00). The connecting lead enters the 605 A/B or 690+B drive through the gland plate.

- Remove the terminal cover and screws.
- On 605A/B and 690+B units, plug the ribbon cable into the back of the Technology Box and into the socket on the drive.
- Click the Technology Box into place in the recess on the front of the drive. If provided, secure in position by tightening the captive screw on the bottom right hand corner of the Option.
- Make all user wiring connections. Refer to the Wiring Diagram.
- On 605A/B and 690+B connect TB1 terminal 6 to the drive chassis.
- Re-fit the terminal cover securely with the screws.

Wiring Diagram Example

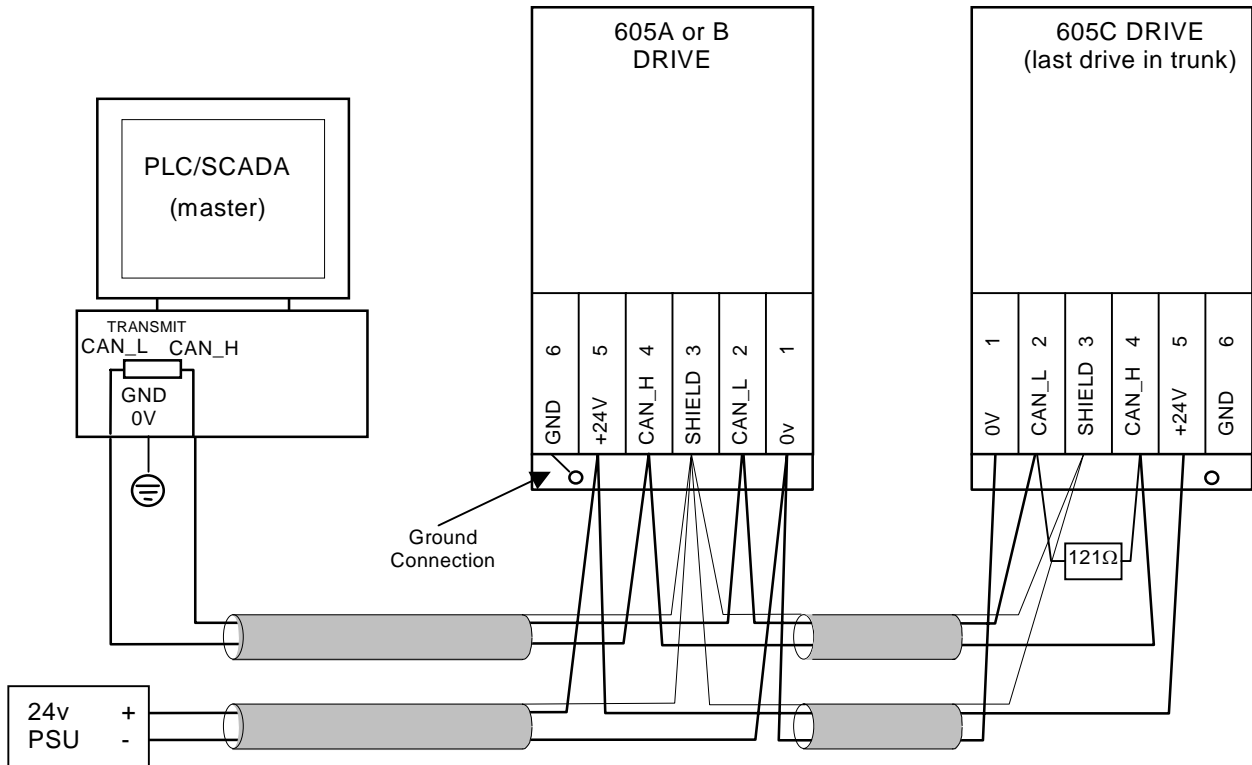

Figure 5 Typical Wiring Diagram

Note: The diagram above shows the terminal block orientation for the **FRONT-VIEW** of both Technology Boxes. Therefore the 605A or B shows terminals numbered right to left, the 605C shows them numbered left to right.

Initial Check for Connection

With the Technology Box configured correctly, and with correct connections to the active PLC/SCADA supervisor, the MODULE LED will be ON continuously indicating the Device Operational state, and the NETWORK LED will indicate the On-Line, Not Connected state with a long flash.

ON		MODULE LED
LONG FLASH		NETWORK LED

Understanding the LED Indications

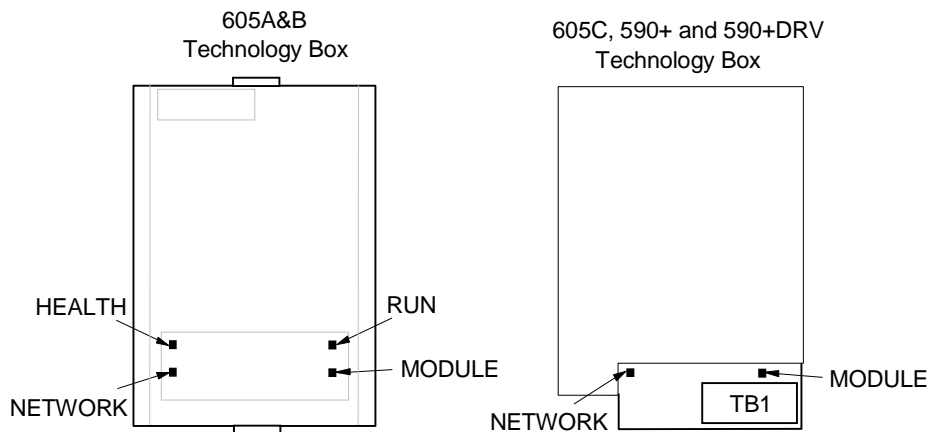

Figure 6 Technology Option LEDs

HINT: The general rule for LED indications is “ON IS GOOD, OFF IS BAD”

Health and Run LEDs

605A & B, 690+B Technology Box





These LEDs reproduce the indications of the LEDs on the drive that are hidden by the fitting of the Technology Box.

590+, 605C, 690+C, 584SV Technology Box

The board does not have its own Health or Run LEDs. The LEDs are either on the Operator Station or blank cover.





Module LED Indications

The states indicated by the Module LED correspond to the Health LED defined by the DeviceNet standard. For a detailed description of possible causes and remedies, refer to the Troubleshooting section on page 63.

LED Indication	State	Description
OFF 	No Power	There is no power applied to the device.
SHORT FLASH 	Critical Fault	The device has an unrecoverable fault; it may need replacing.
FLASH 	Minor Fault	Recoverable fault.
LONG FLASH 	Device Needs Commissioning	The device needs commissioning due to configuration missing, incomplete or incorrect.
ON 	Device Operational	The device is operating in a normal condition.

Network LED Indications

The states indicated by the Network LED correspond to the Communication LED defined by the DeviceNet standard. For a detailed description of possible causes and remedies, refer to the Troubleshooting section on page 63.

LED Indication	State	Description
OFF 	Not Powered / Not On-line	Device is not on-line. The device has not completed the Duplicate MAC ID test. The device may not be powered, look at the Module LED.
SHORT FLASH 	Critical Link Failure	Failed communication device. The device has detected an error that has rendered it incapable of communicating on the network (Duplicate MAC ID, or Bus-off).
FLASH 	On-line, Not Connected	Device has been on-line but has timed out.
LONG FLASH 	On-line, Not Connected	Device is on-line but has no connections in the established state. The device has passed the Duplicate MAC ID test, is on-line, but has no established connections to other nodes, i.e. the device is not allocated to a master.
ON 	Link OK, On-line, Connected	The device is on-line and has connections in the established state, i.e. the device is allocated to a master.

Initial Set-up for DeviceNet

Configuring the Drive

MMI Menu Map (605A, B, C)

Non-specific MMI view

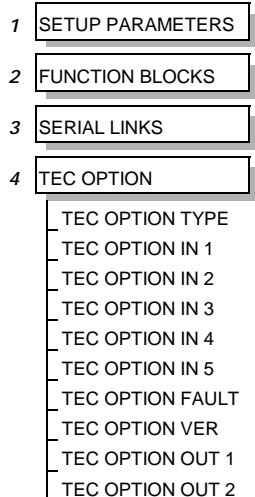

MMI Menu Map (605A, B, C)

DEVICENET view

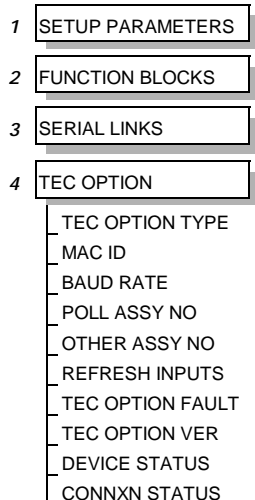

MMI Menu Map (locating TEC OPTION for the 690+)

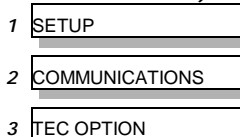

SERIAL LINKS is at Menu Level 1 for the 590+ and 590+DRV.

Using the Operator Station (MMI) or other suitable PC programming tool, the TEC OPTION function block requires configuring before the DEVICENET option can be used.

The parameter names/functions in this function block are inter-dependent and will change with different parameter values and the various Options that can be fitted.

The top Function Block diagram shows the ConfigEd Lite parameter names, which are also displayed on the MMI if no Option is fitted or an incorrect TYPE is selected for the fitted Option.

ConfigEd Lite is Eurotherm Drives' Windows-based block programming software.

When the TYPE parameter is set to display DEVICENET, the function block parameters take on new identities, as shown in the lower Function Block diagram.

Selecting DEVICENET

(Select Advanced view level on the Operator Station and view the TEC OPTION function block).

- Select DEVICENET in the TYPE parameter
- Enter a slave MAC ID
- Enter a baud rate
- Select a poll number if you intend to use Polled I/O or Cyclic messaging
- Toggle REFRESH INPUTS from TRUE to FALSE.
- Check the FAULT parameter for error messages, rectify if necessary

When setting values for parameters from ConfigEd Lite (or other suitable PC programming tool) you are able to select any value in the parameter's range, i.e. -32768 to 32767. If the value is incorrect, i.e. it doesn't correspond to a value that can be set using the MMI, then the FAULT output parameter will be set to PARAMETER after REFRESH INPUTS has been toggled from TRUE to FALSE.

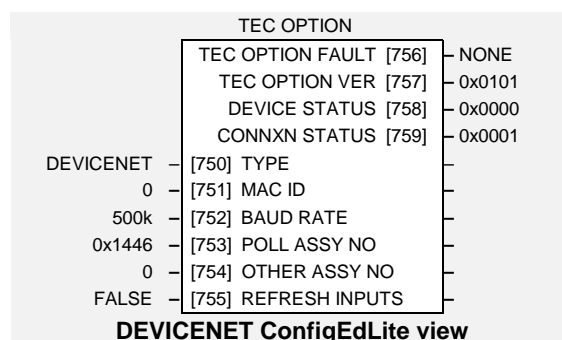
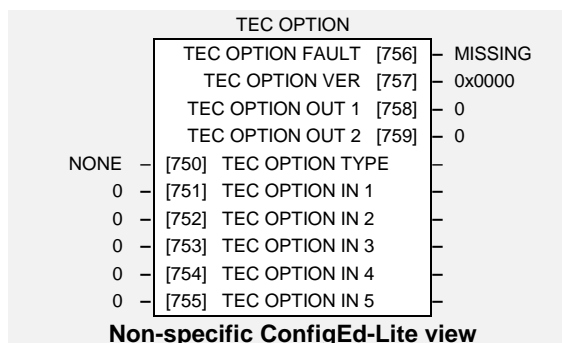

MMI Parameter Descriptions for DEVICENET

TEC OPTION TYPE

Range: Enumerated - see below

Selects the type of Technology Option card.

Enumerated Value : Technology Option

- 0 : NONE
- 1 : RS485
- 2 : PROFIBUS DP
- 3 : LINK
- 4 : DEVICENET
- 5 : CANOPEN
- 6 : LONWORKS
- 7 : TYPE 7

In order for a change in TEC OPTION TYPE to have effect, REFRESH INPUTS must be toggled true then false.

MAC ID

Range: 1 to 63

The DeviceNet node address. This is known as the Media Access Control Identifier, or MAC ID. In order for a change in MAC ID to have effect, REFRESH INPUTS must be toggled true then false.

BAUD RATE

Range: Enumerated – see below

The DeviceNet baud rate.

CE-lite value MMI value

- 0 : 125 kbaud
- 1 : 250 kbaud
- 2 : 500 kbaud

In order for a change in BAUD RATE to have effect, REFRESH INPUTS must be toggled true then false.

POLL ASSY NO

Range: 0x0000 to 0xFFFF

Selects assembly numbers for Connection Object instance 2 (the Polled I/O connection as allocated by the Pre-defined Master-Slave Connection Set). The leftmost two digits select the producer's path; the rightmost two digits select the consumer's path. A producer transmits messages; a consumer receives them.

Each pair of digits represents an instance in hexadecimal format.

The default value is 0x4614, which selects assembly objects 0x46 (70 decimal) and 0x14 (20 decimal).

In order for a change in POLL ASSY NO to have effect, REFRESH INPUTS must be toggled true then false.

OTHER ASSY NO

Selects assembly number for Cyclic connection. The leftmost two digits select the producer's path; the rightmost two digits are not significant.

The assembly number represents an instance in hexadecimal format.

The default value is 0x4614, which selects assembly object 0x46 (70 decimal).

In order for a change in OTHER ASSY NO to have effect, REFRESH INPUTS must be toggled true then false.

REFRESH INPUTS

Used to register a change in TEC OPTION TYPE, MAC ID, BAUD RATE, POLL ASSY NO and OTHER ASSY NO. It may also be required to register a change in cyclic connection rate, depending on the host. It must be FALSE in normal operation, and toggled TRUE then FALSE before a change in any of these parameters will be recognised.

MMI Parameter Descriptions for DEVICENET

FAULT

Range: Enumerated - see below

The fault state of the Technology Option.

0 : NONE	no faults
1 : PARAMETER	parameter out-of-range
2 : TYPE MISMATCH	TYPE parameter not set to DEVICENET
3 : SELF TEST	hardware fault – internal
4 : HARDWARE	hardware fault – external
5 : MISSING	no option fitted

VERSION

Range: 0000 to FFFF

The version of the Technology Option card. If no option is fitted then the version is reset to zero.

DEVICE STATUS

The status of the connection between the host drive and the Technology Option card. This is a copy of the DeviceNet Identity Object (Class 1) Instance 1 Attribute 5 (Status). For more information refer to the DeviceNet specification, volume II. Its value is interpreted by examining each bit:

- BIT 0: OWNED
- BIT 2: CONFIGURED
- BIT 8: MINOR RECOVERABLE FAULT
- BIT 9: MINOR NON-RECOVERABLE FAULT
- BIT 10: MAJOR RECOVERABLE FAULT
- BIT 11: MAJOR NON-RECOVERABLE FAULT
- BITS 1, 3, 4, 5, 6, 7, 12, 13, 14, 15: RESERVED

OWNED

TRUE indicates the device (or an object within the device) has an owner.

CONFIGURED

TRUE indicates the application of the device has been configured to do something other than the “out-of-box” default. This does not include configuration of the communications.

MINOR RECOVERABLE FAULT

TRUE indicates the device detected a problem with itself, which is thought to be recoverable. The problem does not cause the device to go into one of the faulted states.

MINOR NON-RECOVERABLE FAULT

TRUE indicates the device detected a problem with itself, which is thought to be non-recoverable. The problem does not cause the device to go into one of the faulted states.

MAJOR RECOVERABLE FAULT

TRUE indicates the device detected a problem with itself, which caused the device to go into the “other faults” state.

MAJOR NON-RECOVERABLE FAULT

TRUE indicates the device detected a problem with itself, which caused the device to go into the “other faults” state.

RESERVED

Not used, these bits are always set to 0.

MMI Parameter Descriptions for DEVICENET

CONNXN STATUS

Range: Enumerated - see below

The connection status of the Technology Option card.

The Technology Option card can establish 3 connections types with a master device, i.e explicit, polled I/O and cyclic. The CONNXN STATUS word identifies the status of each connection. It is displayed as a four digit hexadecimal value:

- First digit (most significant) – not used. Always 0
- Second digit – Cyclic connection status
- Third digit – Polled I/O connection status
- Fourth digit (least significant) – Explicit connection status.

Each status digit can display one of the following values:

Enumerated Value : Fault State

- 0 : NON-EXISTENT
- 1 : CONFIGURING
- 2 : WAITING FOR CONNECTION ID
- 3 : ESTABLISHED
- 4 : TIMED OUT
- 5: DEFERRED DELETE

NON-EXISTENT

The connection has yet to be instantiated.

CONFIGURING

The connection is waiting to be properly configured and to be told to apply the configuration.

WAITING FOR CONNECTION ID

The connection is configured except for the connection Ids for its consumed and/or produced data, from which the relevant CAN identifiers are determined.

ESTABLISHED

The connection is operational.

TIMED OUT

This state indicates that a watchdog timeout has occurred on this connection, and the connection is configured to enter this state in this event.

DEFERRED DELETE

This state indicates a watchdog timeout has occurred on the Explicit connection while a Cyclic or Polled I/O connection is established.

Configuring the PLC/SCADA Supervisor

Other than setting the TEC OPTION TYPE, ADDRESS, BAUD RATE and ASSY POLL NO or OTHER ASSY NO within the Drive, as described earlier, all configuration is done via a DeviceNet configuration tool, such as DeviceNet Manager. Refer to the documentation for your configuration tool.

The DeviceNet technology option supports three methods of accessing drive parameter information:

- Explicit messaging, connection instance ID #1. This method allows individual access to any tag within the host drive. It also provides conformance with the DeviceNet Drive profiles.
- Polled I/O connection, connection instance ID #2. This method allows access to a tags within the host drive by means of assembly objects. Some of the assembly objects defined in the DeviceNet Drive profile are supported, as well as some unique to this product.
- Cyclic connection, connection instance ID#3. This method allows a drive regularly to report diagnostic and parameter values to a DeviceNet master, without being prompted.

Other connection instances (e.g. Bit-strobe I/O Connection) are not supported.

Configuration Tools

Typical PLC configuration tools are DeviceNet Manager and RsNetWorx, both supplied by Rockwell Software Inc. These are graphical tools that run on a PC. In order to simplify their operation, they rely on Electronic Data Sheet (EDS) files which describes some features of DeviceNet products. This manual includes a floppy disk containing EDS files for all Eurotherm Drives products which are capable of supporting DeviceNet.

Explicit Messaging

Through explicit messaging, the DeviceNet technology option provides the ability to access any tag within the host drive. It can cause the drive to save and restore parameters and similar commands, and it also supports Motor Data, Control Supervisor and and AC/DC Drive Objects defined in the Devicenet Specification, volume II, chapter 6.

Explicit messages are identified by a class number, instance number and attribute number.

The following class numbers are supported:

Class Number	Name	Description
0x01	Identity Object	Provides identification of and general information about the device
0x02	Message Router	Provides a messaging connection point
0x03	DeviceNet Object	Provides the configuration and status of a physical attachment to DeviceNet
0x04	Assembly Object	Binds attributes of multiple objects
0x05	DeviceNet Connection Object	Manages the characteristics of a communication connection
0x28	Motor Data Object	A database of motor parameters
0x29	Control Supervisor Object	Models all the management functions for devices within the heirarchy of motor control devices
0x2A	AC/DC Drive Object	Models the functions specific to an AC or DC drive
0x64	Tags 1 to 100	Provides access to drive tags in the range 1 to 100
0x65	Tags 101 to 200	Provides access to drive tags in the range 101 to 200
0x66	Tags 201 to 300	Provides access to drive tags in the range 201 to 300
0x67	Tags 301 to 400	Provides access to drive tags in the range 301 to 400
0x68	Tags 401 to 500	Provides access to drive tags in the range 401 to 500
0x69	Tags 501 to 600	Provides access to drive tags in the range 501 to 600
0x6A	Tags 601 to 700	Provides access to drive tags in the range 601 to 700
0x6B	Tags 701 to 800	Provides access to drive tags in the range 701 to 800
0x6C	Tags 801 to 900	Provides access to drive tags in the range 801 to 900
0x6D	Tags 901 to 1000	Provides access to drive tags in the range 901 to 1000
0x6E	Tags 1001 to 1100	Provides access to drive tags in the range 1001 to 1100
0x6F	Tags 1101 to 1200	Provides access to drive tags in the range 1101 to 1200
0x7F	Remote config	Provides a means of remotely configuring the drive

Identity Object

For details, refer to the DeviceNet Standard Volume 2, Chapter 6 which defines the Identity Object.

Class = 0x01

Instance = 0x01

The following attributes defined by the Identity Object are supported:

Attribute Number	Description
1	Vendor ID = 0x002D (Eurotherm)
2	Product type = 0x0002 (AC drive) or 0x0013 (DC drive)
3	Product code = drive's product identifier, e.g. 605A drive return 0x0605
4	Revision = Technoloby Box's software revision number, e.g. 0x0102 is revision 1.2 (major revision 1, minor version 2)
5	Status – a bit field defining the status of the DeviceNet technology option. Bit 0 = Owned Bit 2 = Configured Bit 8 = Minor recoverable fault Bit 9 = Minor non-recoverable fault Bit 10 = Major recoverable fault Bit 11 = Major non-recoverable fault Bits 1, 3, 4, 5, 6, 7, 12, 13, 14 and 15 = reserved
6	Serial Number of the DeviceNet technology option
7	Product name

Message Router Object

For details, refer to the DeviceNet Standard Volume 2, Chapter 6 which defines the Message Router Object.

Class = 0x02

Instance = 0x01

The following attributes defined by the Identity Object are supported:

Attribute Number	Description
2	Maximum number of connections supported.

DeviceNet Object

For details, refer to the DeviceNet Standard Volume 2, Chapter 6 which defines the DeviceNet Object.

Class = 0x03

Instance = 0x01

The following attributes defined by the Identity Object are supported:

Attribute Number	Description
1	MAC ID
2	Baud rate
3	Bus-Off Interrupt
4	Number of times CAN went to the bus-off state
5	Structure containing an Allocation Choice Byte and the master's MAC ID

Assembly Object

For details, refer to the DeviceNet Standard Volume 2, Chapter 6, which defines the Identity Object.

Class = 0x04

For range of instance numbers, refer to the POLLED I/O section

DeviceNet Connection Object

For details, refer to the DeviceNet Standard Volume 2, Chapter 6, which defines the DeviceNet Connection Object.

Class = 0x05

Instance = 0x01 (explicit connection)
 = 0x02 (polled I/O connection)
 = 0x04 (cyclic connection)

The following attributes defined by the Identity Object are supported:

Attribute Number	Description
1	State
2	Instance_type
3	Transportclass_trigger
4	Produced_connection_id
5	Consumed_connection_id
6	Initial_comm_characteristic
7	Produced_comm_characteristic
8	Consumed_connection_size
9	Expected_packet_rate
12	Watchdog_timeout_action
13	Produced_connection_path_length
14	Produced_connection_path
15	Consumed_connection_path_length
16	Consumed_connection_path_length
17	Production_inhibit_time

Motor Data Object

This class forms part of DeviceNet's drive profile, and is described in the DeviceNet Standard Volume II.

Class = 0x28

Instance = 0x01

Mapping attributes within this class to drive parameters varies with drive model. The following pages provide details for 605, 584SV and 590+ drives.

Control Supervisor Object

This class forms part of DeviceNet's drive profile, and is described in the DeviceNet Standard Volume II.

Class = 0x29

Instance = 0x01

Mapping attributes within this class to drive parameters varies with drive model. The following pages provide details for 605, 584SV and 590+ drives.

AC/DC Drive Object

This class forms part of DeviceNet's drive profile, and is described in the DeviceNet Standard Volume II.

Class = 0x29

Instance = 0x01

Mapping attributes within this class to drive parameters varies with drive model. The following pages provide details for 605, 584SV and 590+ drives.

Motor Data Object. Class code 28hex.

Refer to DeviceNet Object Library, volume II, chapter 6, section 6-28

Attributes supported:

Attribute ID	Name	Access	DeviceNet Data Type	Description	Conversion from Drive Tag
3	MotorType	Get	USINT	7 = Squirrel Cage Induction Motor	Fixed value
6	RatedCurrent	Get	UINT	Rated Stator Current [100mA]	= tag 64
7	RatedVoltage	Get	UINT	Rated Base Voltage [V]	= (tag 122) / 10

Motor Control Supervisor Object. Class code 29hex.

Refer to DeviceNet Object Library, volume II, chapter 6, section 6-29

Attributes supported:

Attribute ID	Name	Access	DeviceNet Data Type	Description	Conversion from Drive Tag
3	RunFwd	Set/Get	BOOL	1 = Run Forward	= tag 291 (See note)
4	RunRev	Set/Get	BOOL	1 = Run Reverse	= tag 292
5	NetCtrl	Get	BOOL	0 = Run / Stop control is local. 1 = Run / Stop control is from DeviceNet.	= 1 if tag 307 is 0 or 2
7	RunningFwd	Get	BOOL	1 = Drive is running forward	= tag 291 AND tag 285
8	RunningFwd	Get	BOOL	1 = Drive is running reverse	= tag 292 AND tag 285
9	Ready	Get	BOOL	1 = Drive is ready	= tag 287

Note: By default, tag 291 is the destination of a link. In order to set this attribute, the link must be disconnected. Refer to your drive manual.

10	Faulted	Get	BOOL	1 = Drive has tripped	= NOT tag 274
12	FaultRst	Set/Get	BOOL	1 = Reset the trip condition.	= tag 282
13	FaultCode	Get	UINT	<p>FaultCode</p> <p>0000 = No fault 1000 = External trip 2200 = Overcurrent trip 2220 = Current limit 2250 = Short Circuit 2300 = I * T trip 3110 = Link Overvolts 3120 = Link Undervolts 3130 = Phase Fail 4210 = Motor Temperature 4310 = Heatsink Temperature 5112 = 24v Supply Failure 7110 = Brake Resistor 7111 = Brake Switch 7121 = Motor Stalled 7200 = Input 1 or Input 2 Break 7310 = Low Speed 7500 = Operator Station Fault 7510 = Communications Lost</p>	<p>Tag 6</p> <p>0 (No trip) 5 (External trip) 18 (Current limit) 3 (Overcurrent) 19 (Short circuit) 9 (I*T trip) 1 (Link overvolts) 2 (Link undervolts) 22 (Phase fail) 17 (Motor temperature) 4 (Heatsink temperature) 20 (24v failure) 10 (Brake resistor) 11 (Brake switch) 8 (Motor stalled) 6 (Input 1 break) or 7 (Input 2 break) 21 (Low speed) 12 (Operator station) 13 (Lost comms)</p>
102	DriveEnable	Set/Get	BOOL	1 = Drive Enabled	= tag 276

AC/DC Drive attributes. Class code 2Ahex.

Refer to DeviceNet Object Library, volume II, chapter 6, section 6-30

Attributes supported:

Attribute ID	Name	Access	DeviceNet Data Type	Description	Conversion from Drive Tag
3	AtReference	Get	BOOL	1 = Drive has achieved speed or torque reference.	= NOT tag 698
4	NetRef	Get	BOOL	0 = Torque or speed setpoint from local source (terminals or 6051) 1 = Torque or speed setpoint from DeviceNet	= 1 if tag 308 is 0 or 2
6	DriveMode	Set/Get	USINT	1 = Open Loop (V/F) Speed Control 2 = Closed Loop Speed Control 3 = Torque Control	= 1 if tag 118 is 0 AND tag 366 is 0 = 2 if tag 118 is 1 = 3 if tag 118 is 0 and tag 366 is 1
7	SpeedActual	Get	INT	Actual Drive Speed [RPM]	= 3 * tag 591 / (tag 84 + 1)
8	SpeedRef	Set/Get	INT	Speed Reference [RPM]	= 0.3 * tag 269 / (tag 84 + 1) (See note 1)

Note: Remote setpoint operates only when Remote Reference Comms mode is selected. Refer to the manual for your drive.

Motor Data Object. Class code 28hex.

Refer to DeviceNet Object Library, volume II, chapter 6, section 6-28

Attributes supported:

Attribute ID	Name	Access	DeviceNet Data Type	Description	Conversion from Drive Tag
3	MotorType	Get	USINT	2 = Field controlled DC Motor	Fixed value
6	RatedCurrent	Get	UINT	Rated Current [100mA]	= tag 523
7	RatedVoltage	Get	UINT	Rated Voltage [V]	= tag 521

Motor Control Supervisor Object. Class code 29hex.

Refer to DeviceNet Object Library, volume II, chapter 6, section 6-29

Attributes supported:

Attribute ID	Name	Access	DeviceNet Data Type	Description	Conversion from Drive Tag
3	RunFwd	Set/Get	BOOL	1 = Run Forward	= tag 536 bits 0 and 1
4	RunRev	Get (see note 1)	BOOL	0 = Not running reverse	Fixed value
5	NetCtrl	Set/Get	BOOL	0 = Run / Stop is under terminal control only. 1 = Run / Stop is under comms control.	= tag 535
7	RunningFwd	Get	BOOL	1 = Drive is running forward	= tag 537 bits 8 AND 9 AND 12
8	RunningRev	Get	BOOL	0 = Drive is not running reverse	Fixed value
9	Ready	Get	BOOL	1 = Drive is ready	= tag 537 bit 12

Note 1: Get/Set is required by the DeviceNet profile, but no suitable parameter exists within the drive, so Set is not supported.

10	Faulted	Get	BOOL	1 = Drive has tripped	= NOT tag 537 bit 11
12	FaultRst	Set/Get	BOOL	1 = Reset the trip condition.	= tag 536 bit 8
13	FaultCode	Get	UINT	<p>FaultCode</p> <p>0000 = No fault 1000 = General fault</p> <p>2221 = Continuous overcurrent no. 1 2222 = Continuous overcurrent no. 2 3130 = Phase failure 3310 = Output overvoltage 3330 = Field circuit 4300 = Drive temperature 5000 = Hardware 5210 = Measurement circuit 5300 = Operator control circuit 5400 = Power section 6000 = Device software 6320 = Parameter error 7121 = Motor blocked 7120 = Motor 7301 = Tacho defective 7305 = Incremental encoder no. 1 7310 = Speed 8100 = Communication 8112 = Synchronisation fault 8113 = No command 9000 = External malfunction</p>	<p>Tag 528</p> <p>0x0000 (no trip) 0xf001 (autotune error) or 0xf002 (autotune aborted) 0x2000 (armature current) 0x0004 (field current) 0x0200 (phase failure) 0x0020 (overvolts) 0x0100 (field failed) 0x0008 (heatsink trip) 0xff05 (pcb version) 0x8000 (accts failed) 0xf400 (no operator station) 0x0002 (missing pulse) 0xff06 (product code) 0xf200 (config enabled) 0x1000 (stall trip) 0x0010 (motor thermistor) 0x0040 (speed feedback) 0x0080 (encoder failed) 0x0001 (overspeed) 0x0800 (5703 receive error) 0x0400 (phase lock) 0xf006 (remote trip) 0xf005 (external trip)</p>

AC/DC Drive attributes. Class code 2Ahex.

Refer to DeviceNet Object Library, volume II, chapter 6, section 6-30

Attributes supported:

Attribute ID	Name	Access	DeviceNet Data Type	Description	Conversion from Drive Tag
3	AtReference	Get	BOOL	1 = Drive has achieved speed or torque reference.	= NOT tag 113
4	NetRef	Set/Get	BOOL	0 = Torque or speed setpoint from terminals 1 = Torque or speed setpoint from DeviceNet	= tag 346 (see note 1)
6	DriveMode	Set/Get	USINT	2 = Closed Loop Speed Control 3 = Torque Control	= 2 if tag 119 is 0 = 3 if tag 119 1
7	SpeedActual	Get	INT	Actual Drive Speed [RPM]	= (tag 22 * tag 207) / 10000 (See note 2)
8	SpeedRef	Set/Get	INT	Speed Reference [RPM]	= (tag 22 * tag 339) / 10000 (See notes 1 and 2)

Note 1: tags 339 and 346 are unconnected tags. They must be connected to appropriate destination tags in the drive by the user, and other links may need to be removed. Refer to the drive manual.

Note 2: Tag 22 is defined as encoder maximum RPM. In order for these attributes to set and return correct values, it must be set for all speed feedback devices.

Drive Tag Access

DeviceNet master devices can access drive tags as follows:

Class	Instance Number	Drive Tag Number
100	1	1
	2	2

	100	100
101	1	101

	100	200
102	1 to 100	201 to 300
103	1 to 100	301 to 400
104	1 to 100	401 to 500
105	1 to 100	501 to 600
106	1 to 100	601 to 700
107	1 to 100	701 to 800
108	1 to 100	801 to 900
109	1 to 100	901 to 1000
110	1 to 100	1001 to 1100
111	1 to 100	1101 to 1200
112	1 to 100	1201 to 1300
113	1 to 100	1301 to 1400
114	1 to 100	1401 to 1500

Within each class and instance, operations possible are:

- `get_attribute_single` – reads the data value of a drive tag
- `get_attributes_all` – reads all attributes of a drive tag
- `set_attribute_single` – writes a value to a drive tag

`get_attribute_single`

This operation returns the data value of a drive tag. The value is returned in attribute 2. All other attributes are invalid in this operation.

`get_attributes_all`

This operation returns the following values:

- Tag number in hexadecimal. It consists of two bytes, least significant first.
- One byte containing data type, conforming to the following

Data Type	Name	Description	Range
0x01	BOOL	A boolean (bit) representing TRUE or FALSE	0 = FALSE 1 = TRUE
0x03	WORD	16 bit hexadecimal number	0000 to FFFF (hexadecimal)
0x07	INT	A numeric value that may be either positive or negative. INT types may have decimal points.	The upper and lower limits of the parameter. Indicating the parameter's true, internally-held, number.
0x11	ENUM	An enumerated value representing a selection.	A list of possible selections for that parameter.

Note that STRING type is not supported and will report an error if an attempt is made to access a tag of data type STRING .

- Lower limit. Data types BOOL and ENUM return a single byte, WORD and INT return a 16 byte value in two bytes, least significant first.
- Upper limit. Data types BOOL and ENUM return a single byte, WORD and INT return a 16 byte value in two bytes, least significant first.
- Data value. Data types BOOL and ENUM return a single byte, WORD and INT return a 16 byte value in two bytes, least significant first.

set_attribute_single

This operation provides a means of setting the value of a drive tag. Any attribute number may be specified, only the data value can be written.

Remote Configuration

DeviceNet master devices may send commands to the drive, for example, to save parameters and to return the status of saving. These commands are accessed as follows:

Class = 0x7F

Instance = 1

The following table lists the functions available.

Attribute Number	Permitted Operation	Data Value	Function
0x0001	Set	0x0101	Restores Saved Configuration from drive's non-volatile memory (not supported in 590+)
		0x4444	Exit Configuration Mode
		0x5555	Enter Configuration Mode
0x0002	Get	0x0000	Initialising (powering up)
		0x0001	Corrupted Product Code and Configuration
		0x0002	Corrupted Configuration
		0x0003	Restoring Configuration
		0x0004	Re-configuring Mode
		0x0005	Normal Operation Mode
0x0003	Set	0x0000	Reset Command. Acknowledges (clears) any previous save error
		0x0001	Saves Configuration to drive's non-volatile memory
0x0004	Get	0x0000	Idle
		0x0001	Saving in progress
		0x0002	Saving has failed

Polled I/O Connection

Polled I/O connections enable several parameter values to be passed in one transaction. Lists of parameters to be written to the drive and read from it are defined in assembly objects. The user is able to choose from a list of pre-defined assembly object instances, and a DeviceNet technology box can have one polled I/O instance operative in each direction at any time.

Technology boxes provide instances detailed below. Instances 0x14 and 0x46 are defined by the DeviceNet specification, other instances are specific to Eurotherm Drives products. Eurotherm-specific instances indicate the drive tag number that is accessed in each case.

All integer values are presented with the low order byte first (in even byte numbers within an assembly object structure) and high order byte last (in odd byte numbers).

The following table lists the instance numbers (in hexadecimal) that are provided:

Instance Number	Read/Write	Number of bytes transferred	Drives applicable
0x14	Write	4	All
0x46	Read	4	All
0x64	Write	8	690+, 605 (all frame sizes), 584SV
0x65	Write	12	690+, 605 (all frame sizes), 584SV
0x66	Write	10	590+
0x67	Write	14	590+
0x68	Write	14	590+
0x69	Write	12	690+, 605 (all frame sizes), 584SV
0x6A	Write	12	590+
0x6E	Read	10	690+, 605 (all frame sizes), 584SV
0x6F	Read	24	605 (frame sizes A and B)
0x70	Read	30	690+, 605 (frame sizes C to F)
0x71	Read	12	590+
0x72	Read	36	590+

Instance 0x14

Applicable to drive type: All

Access: Write to Technology Box

Byte Number	Description	590+ Drive Tag Number	Other Drive Tag Number
0	Bit-field:		
	0	Run	Tag 536 ¹ bit 1
	1	Reserved	-
	2	Fault Reset	Tag 536 ¹ bit 8
	3	Reserved	-
	4	Reserved	-
	5	Reserved	-
	6	Reserved	-
	7	Reserved	-
1	Reserved		
2,3	Speed Reference (RPM)	$= (\text{tag } 22 * \text{tag } 339^4) / 10000$	$= 0.3 * \text{tag } 269 / (\text{tag } 84 + 1)$

¹ Tag 536 functions only when Rem Seq Enable (tag 535) is true.

² By default, tag 291 is the destination of a link from Digital Input 1. In order to set its value, the link must be disconnected. Refer to your drive manual. Drive Enable (tag 276), Not Fast Stop (tag 277) and Not Coast Stop (tag 278) must all be true before the drive will start.

³ By default, tag 282 is the destination of link 4, from Digital Input 2. In order to set its value, the link must be disconnected. Refer to your drive manual.

⁴ Tag 339 is a miniLINK parameter, and has no functionality. It can be used as a staging post by creating a link in the 590+ from tag 339 to an appropriate speed setpoint tag in the drive. Note that it may be necessary to disconnect other connections for this to operate normally. For example if this input is directed by a link to tag 100 (setpoint 1 in the Speed Loop function block), it is necessary to disconnect the output from Setpoint Sum 1 function block.

Instance 0x46

Applicable to drive type: All

Access: Read from Technology Box

Byte Number	Description	590+ Drive Tag Number	Other Drive Tag Number
0	Bit-field:		
	0	Faulted	NOT tag 537 bit 11
	1	Reserved	-
	2	Running	537 bits 8 AND 9 AND 12
	3	Reserved	-
	4	Reserved	-
	5	Reserved	-
	6	Reserved	-
	7	Reserved	-
1	Reserved		
2,3	SpeedActual (RPM)	$= (\text{tag } 22 * \text{tag } 207) / 10000$	$= 3 * \text{tag } 591 / (\text{tag } 84 + 1)$

Instance 0x64

Applicable to drive type: 690+, 605 (all frame sizes) and 584SV

Access: Write to Technology Box

Byte Number	Description	Drive Tag Number
0	Bit-field:	
	Bit Number	
	0	Run Forward
	1	Run Reverse
	2	Fault Reset
	3	/Stop
	4	Jog
	5	Drive Enable
	6	/Fast Stop
	7	/Coast Stop
1	Bit-field:	
	Bit Number	
	0	UserDefined #1 (preset 8 input 0)
	1	UserDefined #2 (preset 8 input 1)
	2	UserDefined #3 (preset 8 input 2)
	3	UserDefined #4 (preset 8 input 3)
	4	Reserved
	5	Reserved
	6	Reserved
	7	Reserved
2, 3	Speed Reference %	269 ⁴
4, 5	User Defined #1 (preset 8 input 4)	558 ³
6, 7	User Defined #2 (preset 8 input 5)	559 ³

¹ By default, these tags are destinations of link internal drive links from Digital Input user terminals. In order for DeviceNet to control these tags, the appropriate links must be disconnected by setting their destinations to null or 0. Refer to your drive manual.

² These tags control drive sequencing. There are other tags within the drive which enable their respective functions. In particular Remote Seq Mode (tag 307) must be set to be Terminals. This is because DeviceNet sequencing bits connect to tags which are normally controlled by user terminals.

³ Tags 554 to 559 inclusive are inputs to Preset 8 function block. They may be connected by links in the drive to most tags.

⁴ Tag 269 may be written only by communications options, such as the DeviceNet technology option, and is not shown in all representations in drive manuals or ConfigEd Lite. In the 690+ for example, writing to tag 269 will result in the value written appearing on tag 770.

In order for this tag to become the drive setpoint, Rem Comms Sel (tag 300) must be true and Remote Ref Mode (tag 308) must be true.

Instance 0x65

Applicable to drive type: 690+, 605 (all frame sizes) and 584SV

Access: Write to Technology Box

Byte Number	Description	Drive Tag Number	
0	Bit-field:		
	Bit Number		
	0	Run Forward	291 ^{1,2}
	1	Run Reverse	292 ^{1,2}
	2	Fault Reset	282 ^{1,2}
	3	/Stop	293 ^{1,2}
	4	Jog	280 ^{1,2}
	5	Drive Enable	276 ²
	6	/Fast Stop	277 ²
	7	/Coast Stop	278 ²
1	Bit-field:		
	Bit Number		
	0	UserDefined #1 (preset 8 input 0)	554 ³
	1	UserDefined #2 (preset 8 input 1)	555 ³
	2	UserDefined #3 (preset 8 input 2)	556 ³
	3	UserDefined #4 (preset 8 input 3)	557 ³
	4	NetCtrl	Same as Class 0x29, Instance 1, Attribute 5
	5	NetRef	Same as Class 0x2A, Instance 1, Attribute 4
	6	Reserved	-
	7	Reserved	-
2, 3	Speed Reference %	269 ⁴	
4, 5	User Defined #1 (preset 8 input 4)	558 ³	
6, 7	User Defined #2 (preset 8 input 5)	559 ³	
8, 9	User Defined #3 (preset 8 input 6)	560 ³	
10, 11	User Defined #4 (preset 8 input 7)	561 ³	

¹ By default, these tags are destinations of internal drive links from Digital Input user terminals. In order for DeviceNet to control these tags the appropriate links must be disconnected by setting their destinations to null or 0. Refer to your drive manual.

² These tags control drive sequencing. There are other tags within the drive that enable their respective functions. In particular Remote Seq Mode (tag 307) must be set to be Terminals. This is achieved by setting NetCtrl (byte 1 bit 4) to 0. This is because DeviceNet sequencing bits connect to tags that are normally controlled by user terminals.

³ Tags 554 to 561 inclusive are inputs to Preset 8 function block. They may be connected by links in the drive to most tags.

⁴ Tag 269 may be written only by communications options, such as the DeviceNet technology option, and is not shown in all representations in drive manuals or ConfigEd Lite. In the 690+ for example, writing to tag 269 will result in the value written appearing on tag 770.

In order for this tag to become the drive setpoint, Rem Comms Sel (tag 300) must be true and NetRef (byte 1 bit 5) must be 1.

Instance 0x66

Applicable to drive type: 590+

Access: Write to Technology Box

Byte Number	Description	Drive Tag Number	
0, 1	Remote Sequence	536 ¹	
2	Bit-field:		
	Bit Number		
	0	Aux Start	161
	1	Aux Jog	227
	2	Aux Enable	168
	3	Current Control (Enable)	497 ²
	4	UserDefined #1 (miniLINK logic 1)	346 ³
	5	UserDefined #2 (miniLINK logic 2)	347 ³
	6	UserDefined #3 (miniLINK logic 3)	348 ³
7	UserDefined #4 (miniLINK logic 4)	349 ³	
3	Reserved	-	
4, 5	Speed Reference %	309	
6, 7	User Defined #1 (miniLINK value 2)	340 ³	
8, 9	User Defined #2 (miniLINK value 3)	341 ³	

¹ Tag 536 functions only when Rem Seq Enable (tag 535) is true.

² By default, tag 497 is the destination of Digital Input C4. In order for it to function as setpoint, this output must be disconnected. Refer to your drive manual.

³ Tags 340, 341 and 346 to 349 are miniLINK parameters. They have no inherent function, but can be connected by links to any tag in the drive.

Instance 0x67

Applicable to drive type: 590+

Access: Write to Technology Box

Byte Number	Description	Drive Tag Number	
0, 1	Remote Sequence	536 ¹	
2	Bit-field:		
	Bit Number		
	0	Aux Start	161
	1	Aux Jog	227
	2	Aux Enable	168
	3	Current Control (Enable)	497 ²
	4	UserDefined #1 (miniLINK logic 1)	346 ³
	5	UserDefined #2 (miniLINK logic 2)	347 ³
	6	UserDefined #3 (miniLINK logic 3)	348 ³
	7	UserDefined #4 (miniLINK logic 4)	349 ³
3	Reserved	-	
4, 5	Speed Reference %	309	
6, 7	User Defined #1 (miniLINK value 2)	340 ³	
8, 9	User Defined #2 (miniLINK value 3)	341 ³	
10, 11	User Defined #1 (miniLINK value 4)	342 ³	
12, 13	User Defined #2 (miniLINK value 5)	343 ³	

¹ Tag 536 functions only when Rem Seq Enable (tag 535) is true.

² By default, tag 497 is the destination of Digital Input C4. In order for it to function as setpoint, this output must be disconnected. Refer to your drive manual.

³ Tags 340 to 343 and 346 to 349 are miniLINK parameters. They have no inherent function, but can be connected by links to any tag in the drive.

Instance 0x68

Applicable to drive type: 590+

Access: Write to Technology Box

Byte Number	Description	Drive Tag Number
0, 1	Remote Sequence	536 ¹
2	Bit-field:	
	Bit Number	
	0	Aux Start 161
	1	Aux Jog 227
	2	Aux Enable 168
	3	UserDefined #1 (miniLINK logic 1) 346 ²
	4	UserDefined #2 (miniLINK logic 2) 347 ²
	5	UserDefined #3 (miniLINK logic 3) 348 ²
	6	UserDefined #4 (miniLINK logic 4) 349 ²
	7	Reserved -
3	Reserved	-
4, 5	Speed Reference %	309
6, 7	User Defined #1 (miniLINK value 2)	340 ²
8, 9	User Defined #2 (miniLINK value 3)	341 ²
10, 11	User Defined #1 (miniLINK value 4)	342 ²
12, 13	User Defined #2 (miniLINK value 5)	343 ²

¹ Tag 536 functions only when Rem Seq Enable (tag 535) is true.

² Tags 340 to 343 and 346 to 349 are miniLINK parameters. They have no inherent function, but can be connected by links to any tag in the drive.

Instance 0x69

Applicable to drive type: 690+, 605 (all frame sizes) and 584SV

Access: Write to Technology Box

Byte Number	Description	Drive Tag Number	
0, 1	Comms command sequencing word	271 ¹	
2	Bit-field:		
	Bit Number		
	0	UserDefined #1 (preset 6 input 0)	532 ²
	1	UserDefined #2 (preset 6 input 1)	533 ²
	2	UserDefined #3 (preset 6 input 2)	534 ²
	3	UserDefined #4 (preset 6 input 3)	535 ²
	4	UserDefined #5 (preset 6 input 4)	536 ²
	5	UserDefined #6 (preset 6 input 5)	537 ²
	6	UserDefined #7 (preset 6 input 6)	538 ²
7	UserDefined #8 (preset 6 input 7)	539 ²	
3	Reserved		
4, 5	Speed Reference %	269 ³	
6, 7	User Defined #9 (preset 8 input 0)	554 ²	
8, 9	User Defined #10 (preset 8 input 1)	555 ²	
10, 11	User Defined #11 (preset 8 input 2)	556 ²	

¹ Tag 271 may be written only by communications options, such as the DeviceNet technology option, and is not shown in all representations in drive manuals or ConfigEd Lite. In the 690+ for example, writing to tag 271 will result in the value written appearing on tag 273.

In order for this tag to become the drive setpoint, Rem Comms Sel (tag 300) must be true and Remote Ref Mode (tag 308) must be Terminals/Comms or Comms Only.

² Tags 532 to 539 and 554 to 556 are inputs to Preset function blocks. They may be connected by links in the drive to most tags.

³ Tag 269 may be written only by communications options, such as the DeviceNet technology option, and is not shown in all representations in drive manuals or ConfigEd Lite. In the 690+ for example, writing to tag 269 will result in the value written appearing on tag 770.

In order for this tag to become the drive setpoint, Rem Comms Sel (tag 300) must be true and Remote Ref Mode (tag 308) must be Terminals/Comms or Comms Only.

Instance 0x6A

Applicable to drive type: 590+

Access: Write to Technology Box

Byte Number	Description	Drive Tag Number
0, 1	Remote Sequence	536 ¹
2	Bit-field:	
	Bit Number	
	0	UserDefined #1 (PNO 112)
	1	UserDefined #2 (PNO 113)
	2	UserDefined #3 (PNO 114)
	3	UserDefined #4 (PNO 115)
	4	UserDefined #5 (PNO 116)
	5	UserDefined #6 (PNO 117)
	6	UserDefined #7 (PNO 118)
	7	UserDefined #8 (PNO 119)
3	Reserved	-
4, 5	User Defined #9 (PNO 120)	Indirect 320 ²
6, 7	User Defined #10 (PNO 121)	Indirect 321 ²
8, 9	User Defined #11 (PNO 122)	Indirect 322 ²
10, 11	User Defined #12 (PNO 123)	Indirect 323 ²

¹ Tag 536 functions as Remote Sequence only when Rem Seq Enable (tag 535) is true.

² Tags 312 to 323 are indirect parameters. Their values are destination tag numbers for DeviceNet data. For example if the value of tag 320 (PNO 120) is 2, then the value of User Defined #9 (bytes 4,5) will be written to tag 2 (Ramp Accel Time). If some of the UserDefined parameters are not required, the corresponding destination tag numbers should be set to 0.

Instance 0x6E

Applicable to drive type: 690+, 605 (all frame sizes) and 584SV

Access: Read from Technology Box

Byte Number	Description		Drive Tag Number
0	Bit-field:		
	Bit Number		
	0	Tripped	289
	1	Healthy	274
	2	Ready	287
	3	Running	285
	4	Stopping	303
	5	Zero Speed	360
	6	UserDefined #1 (preset 7 input 0)	543
	7	UserDefined #2 (preset 7 input 1)	544
1	Reserved		
2, 3	First trip		6
4, 5	Speed demand %		255
6, 7	User Defined #1 (preset 7 input 4)		547
8, 9	User Defined #2 (preset 7 input 5)		548

Instance 0x6F

Applicable to drive type: 605 frame sizes A and B only

Access: Read from Technology Box

Byte Number	Description	Drive Tag Number	
0	Bit-field:		
	Bit Number		
	0	Tripped	289
	1	Healthy	274
	2	Ready	287
	3	Running	285
	4	Stopping	303
	5	Zero Speed	360
	6	Jogging	302
	7	Ramping	698
1	Bit-field:		
	Bit Number		
	0	Digital input 1	31
	1	Digital input 2	34
	2	Digital input 3	37
	3	Digital input 4	40
	4	Digital input 5	43
	5	Digital input 6	726
	6	Digital input 7	728
	7	Reserved	-
2, 3	Analogue input 1	16	
4, 5	Analogue input 2	25	
6	Bit-field:		
	Bit Number		
	0	Digital output 1	52
	1	Digital output 2	55
	2	UserDefined #1 (preset 7 input 0)	543
	3	UserDefined #2 (preset 7 input 1)	544
	4	UserDefined #3 (preset 7 input 2)	545
	5	UserDefined #4 (preset 7 input 3)	546
	6	Reserved	-
	7	Reserved	-
7	Reserved		
8, 9	Analogue output 1	45	
10, 11	First trip	6	
12, 13	Speed demand %	255	
14, 15	Motor current %	66	
16, 17	User Defined #1 (preset 7 input 4)	547	
18, 19	User Defined #2 (preset 7 input 5)	548	
20, 21	User Defined #3 (preset 7 input 6)	549	
22, 23	User Defined #4 (preset 7 input 7)	550	

Instance 0x70

Applicable to drive type: 690+, 605 (frame sizes C to F inclusive) and 584SV

Access: Read from Technology Box

Byte Number	Description	Drive Tag Number	
0	Bit-field:		
	Bit Number		
	0	Tripped	289
	1	Healthy	274
	2	Ready	287
	3	Running	285
	4	Stopping	303
	5	Zero Speed	360
	6	Jogging	302
	7	Ramping	698
1	Bit-field:		
	Bit Number		
	0	Digital input 1	31
	1	Digital input 2	34
	2	Digital input 3	37
	3	Digital input 4	40
	4	Digital input 5	43
	5	Digital input 6	726
	6	Digital input 7	728
	7	Digital input 8 (value returned by 690+ is undefined)	730
2, 3	Analogue input 1	16	
4, 5	Analogue input 2	25	
6, 7	Analogue input 3	715	
8, 9	Analogue input 4	722	
10	Bit-field:		
	Bit Number		
	0	Digital output 1	52
	1	Digital output 2	55
	2	Digital output 3	737
	3	UserDefined #1 (preset 7 input 0)	543
	4	UserDefined #2 (preset 7 input 1)	544
	5	UserDefined #3 (preset 7 input 2)	545
	6	UserDefined #4 (preset 7 input 3)	546
7	Reserved	-	
11	Reserved		
12, 13	Analogue output 1	45	
14, 15	Analogue output 2	731	
16, 17	First trip	6	
18, 19	Speed demand %	255	
20, 21	Motor current %	66	
22, 23	User Defined #1 (preset 7 input 4)	547	
24, 25	User Defined #2 (preset 7 input 5)	548	
26, 27	User Defined #3 (preset 7 input 6)	549	
28, 29	User Defined #4 (preset 7 input 7)	550	

Instance 0x71

Applicable to drive type: 590+

Access: Read from Technology Box

Byte Number	Description	Drive Tag Number	
0, 1	Sequence Status	537	
2	Bit-field:		
	Bit Number		
	0	UserDefined #1 (miniLINK logic 5)	350
	1	UserDefined #2 (miniLINK logic 6)	351
	2	UserDefined #3 (miniLINK logic 7)	352
	3	UserDefined #4 (miniLINK logic 8)	353
	4	Reserved	-
	5	Reserved	-
	6	Reserved	-
	7	Reserved	-
3	Reserved	-	
4, 5	Health Store Word	116	
6, 7	Speed Feedback %	207	
8, 9	User Defined #1 (miniLINK value 6)	344	
10, 11	User Defined #2 (miniLINK value 7)	345	

Instance 0x72

Applicable to drive type: 590+

Access: Read from Technology Box

Byte Number	Description	Drive Tag Number	
0, 1	Sequence Status	537	
2	Bit-field:		
	Bit Number		
	0	/Program Stop input B8	80
	1	Digital input C3	68
	2	Digital input C4	69
	3	Digital input C5	70
	4	Digital input C6	71
	5	Digital input C7	72
	6	Digital input C8	73
3	Bit-field:		
	Bit Number		
	0	Digital output B5	74
	1	Digital output B6	75
	2	Digital output B7	76
	3	UserDefined #1 (miniLINK logic 5)	350
	4	UserDefined #2 (miniLINK logic 6)	351
	5	UserDefined #3 (miniLINK logic 7)	352
	6	UserDefined #4 (miniLINK logic 8)	353
7	Reserved	-	
4, 5	Analogue Input 1	50	
6, 7	Analogue Input 2	51	
8, 9	Analogue Input 3	52	
10, 11	Analogue Input 4	53	
12, 13	Analogue Input 5	54	
14, 15	Analogue Output 1	55	
16, 17	Analogue Output 2	56	
18, 19	Health Store Word	116	
20, 21	Health word	115	
22, 23	Speed Feedback %	207	
24, 25	Speed demand %	89	
26, 27	Armature current feedback %	65	
28, 29	User Defined #1 (miniLINK value 6)	344	
30, 31	User Defined #2 (miniLINK value 7)	345	
32, 33	User Defined #3 (miniLINK value 8)	379	
34, 35	User Defined #4 (miniLINK value 9)	380	

Cyclic Connection

Cyclic connection is supported on software version 2.1 and later.

Like polled I/O, a cyclic connection enables several parameter values to be passed in one transaction. A cyclic connection allows a network slave to transmit unsolicited data to a network master, the master does not prompt the slave to transmit. A network master cannot transmit data to a network slave by means of a cyclic connection.

Lists of parameters to be transmitted by the drive are defined in assembly objects. The user is able to choose from a list of pre-defined assembly object instances, and a DeviceNet technology box can have only one cyclic instance operative.

Assembly objects can be chosen from a subset of those available in polled I/O connection. Instances available are restricted to read instances only, i.e. instances 0x46, 0x6E, 0x6F, 0x70, 0x71 and 0x72.

The chosen assembly object instance must be entered into the OTHER ASSY NOS entry in the drive's MMI (see page 16).

Note that it may be necessary to refresh inputs (see page 16) after changing the rate at which cyclic data are sent. The correct rate is set up automatically on power-up.

Note that some host PLCs do not permit reliable simultaneous polled I/O and cyclic connections to the same slave device.

Example Configurations

The examples given here are intended to provide the novice user with a quick guide to getting started. They are not intended as comprehensive guides to DeviceNet configuration tools.

The screen shots in this section are reproduced by kind permission of Allen Bradley Inc and Rockwell Inc. They accept no liability for any inaccuracies or omissions herein.

Installing an EDS file into DeviceNet Manager

From the Utilities menu, select Install EDS Files. The following dialogue box appears:

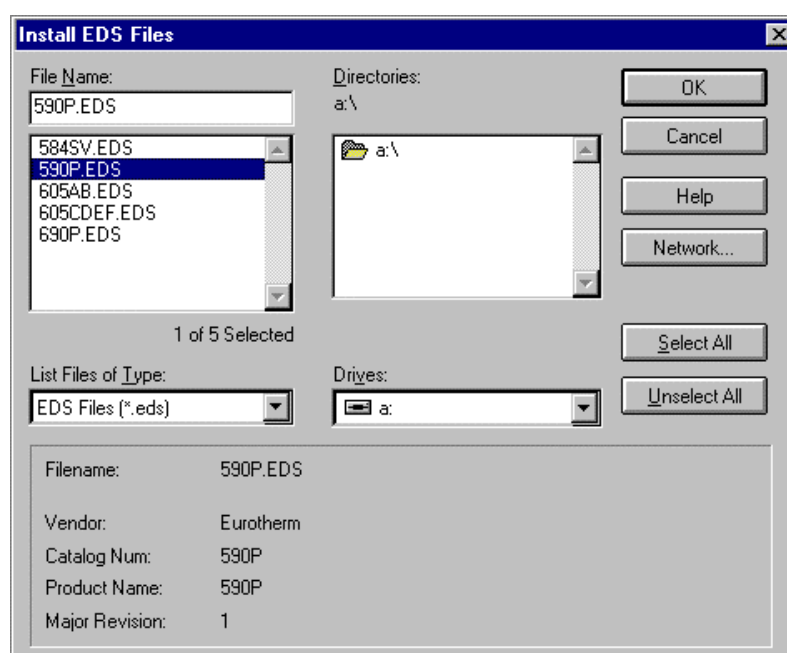

Use the Drives, Directories and File Name boxes to locate and select the EDS file for your drive. The example shows a 590+ drive selected. Click OK. DeviceNet Manager now asks if you want to set a bitmap device:



Eurotherm Drives provides bitmaps for all drives, so click Yes. Another dialogue box appears:

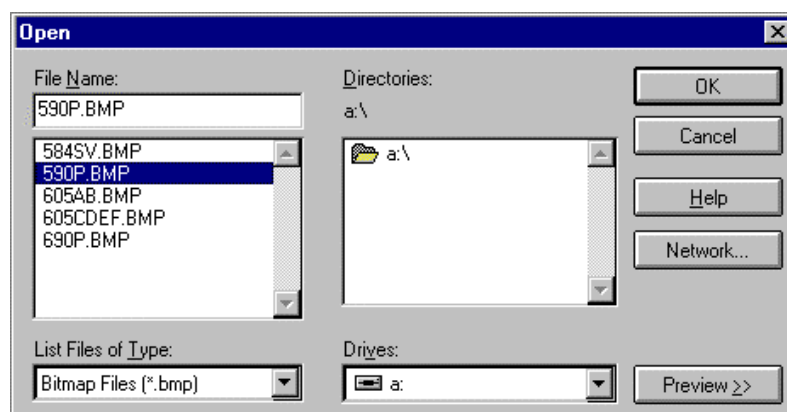

Use the Drives, Directories and File Name boxes to locate and select the bitmap file for your drive. The example again shows a 590+ drive selected. Click OK. Installation is now complete.

Installing an EDS file into RsNetWorx for DeviceNet

From the Tools menu, select EDS Wizard. At the introductory dialogue box, click Next. This dialogue box appears:

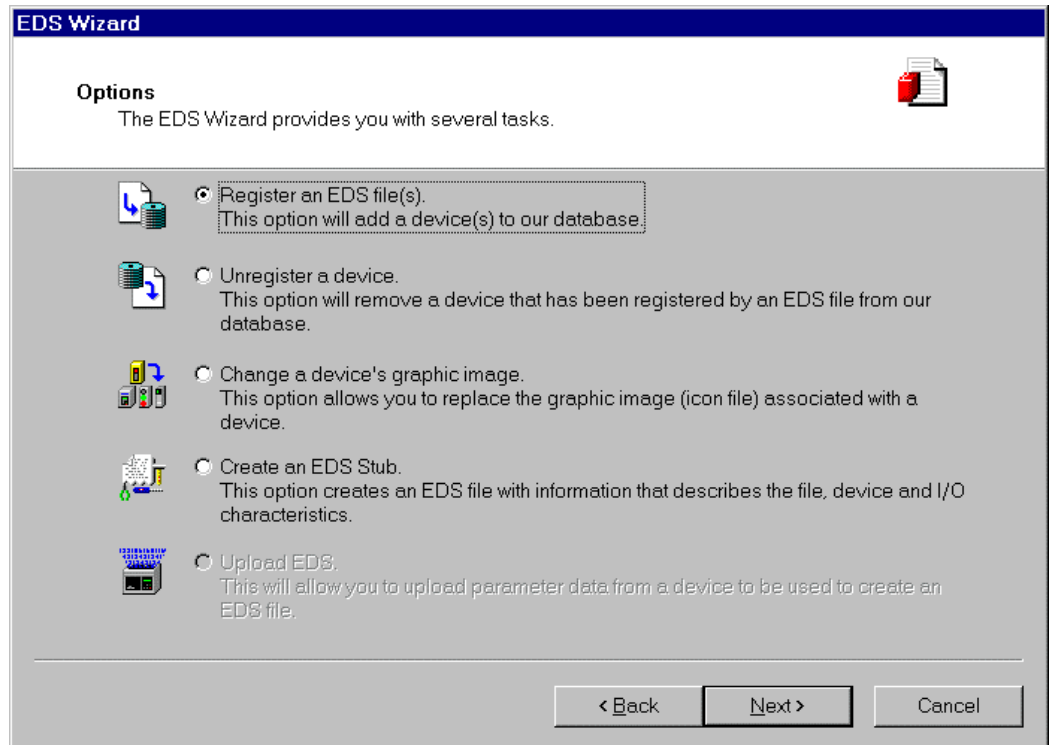

Ensure the Register an EDS file(s) button is pressed, as show, and click Next:

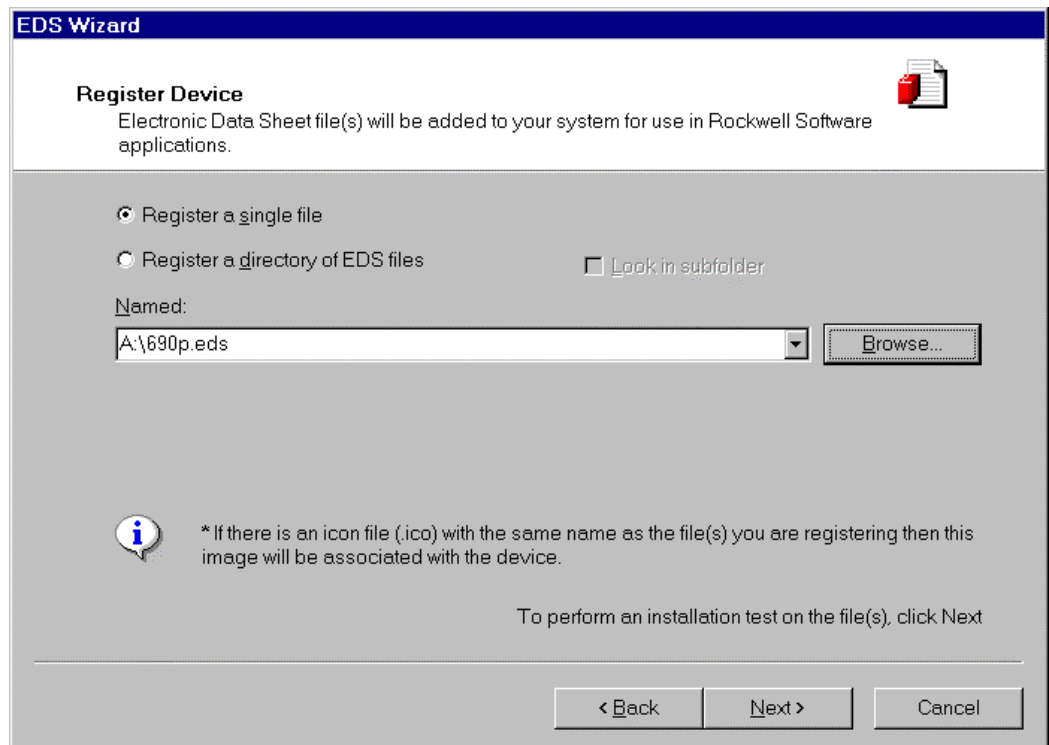

Use the **Browse** button to locate the EDS file, or type in the pathname if you know it. The example shows the EDS file for a 690+ drive has been selected. Then click Next:

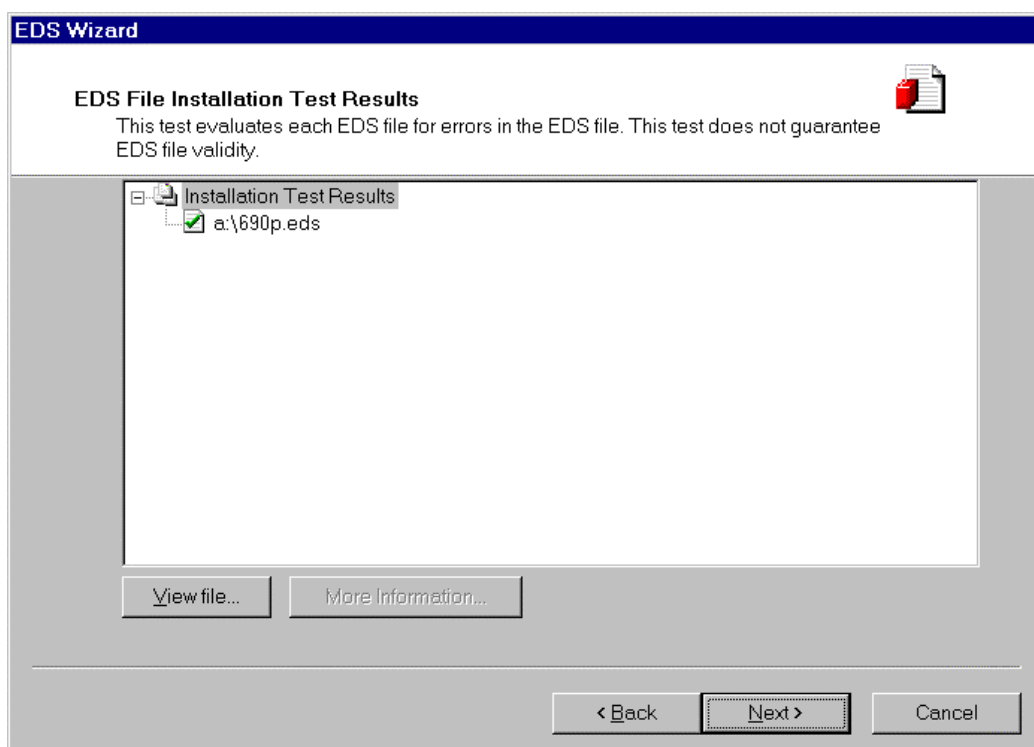

Ensure there is a green tick in the box adjacent to the new EDS file. If not, RxNetWorx has detected a fault in the EDS file, it may be corrupted. Contact Eurotherm Drives Technical Support Desk. Click **N**ext.

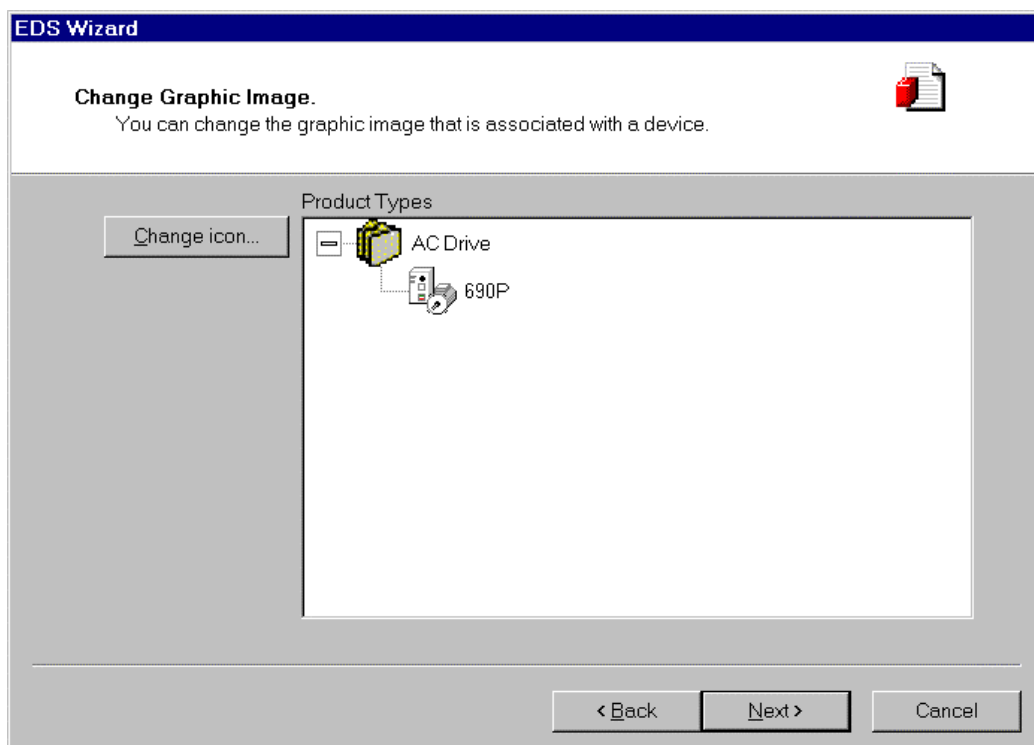

If you wish to install a different icon from that shown, click **C**hange icon, and navigate to the icon of your choice. However this is not necessary, and RsNetWorx will otherwise use its standard, as shown. Click **N**ext.

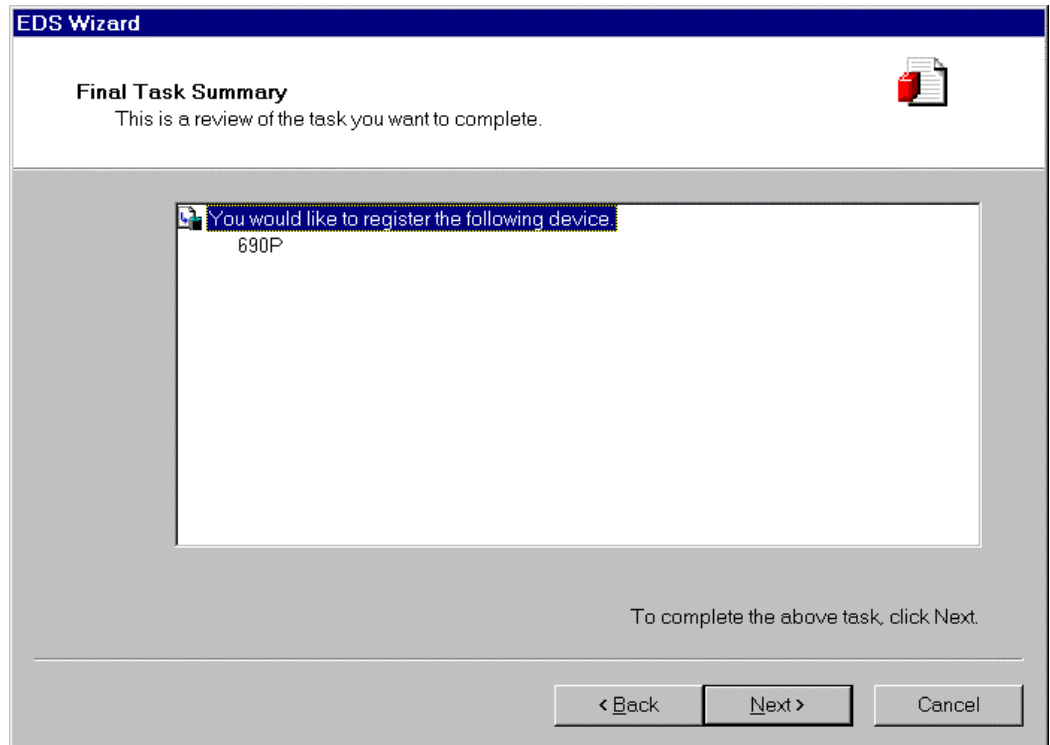

Click Next. The final dialogue box is confirmation that installation is complete. Click Finish.

Configuring a Drive using the Operator Station

This example will configure a 590+ drive as follows:

- MAC ID will be set to 10.
- Baud rate will be set to 125k
- Write assembly object instance 0x66 will be selected, which writes 10 words of data to the drive.
- Read assembly object instance 0x71 will be selected, which reads 12 words of data from the drive.

Locate the TEC OPTION function block in the drive's MMI. Refer to your drive's user manual to locate this if you are unsure.

Ensure the following values are set in the function block:

TEC OPTION TYPE = DEVICENET

MAC ID = 10

BAUD RATE = 125K

POLL ASSY NOS = 0x7166

Now locate the REFRESH INPUTS parameter. If its value is FALSE, use the ▲ key to make it TRUE. Then use the ▼ key to make it FALSE. Drive configuration is now complete.

Configuring the drive's block diagram

It may be necessary to configure the drive's block diagram to provide the required DeviceNet functionality. As a starting point, CE-Lite files, compatible with CE-Lite version 5.05 and later, are provided with this manual which provide this functionality :

- Drive start / stop from DeviceNet
- Drive speed setpoint from DeviceNet
- Stop the drive on DeviceNet communications failure.

Configuring DeviceNet Manager

This section will describe how to set up DeviceNet Manager to use the assembly objects defined in the previous section.

A typical startup screen will appear as below:

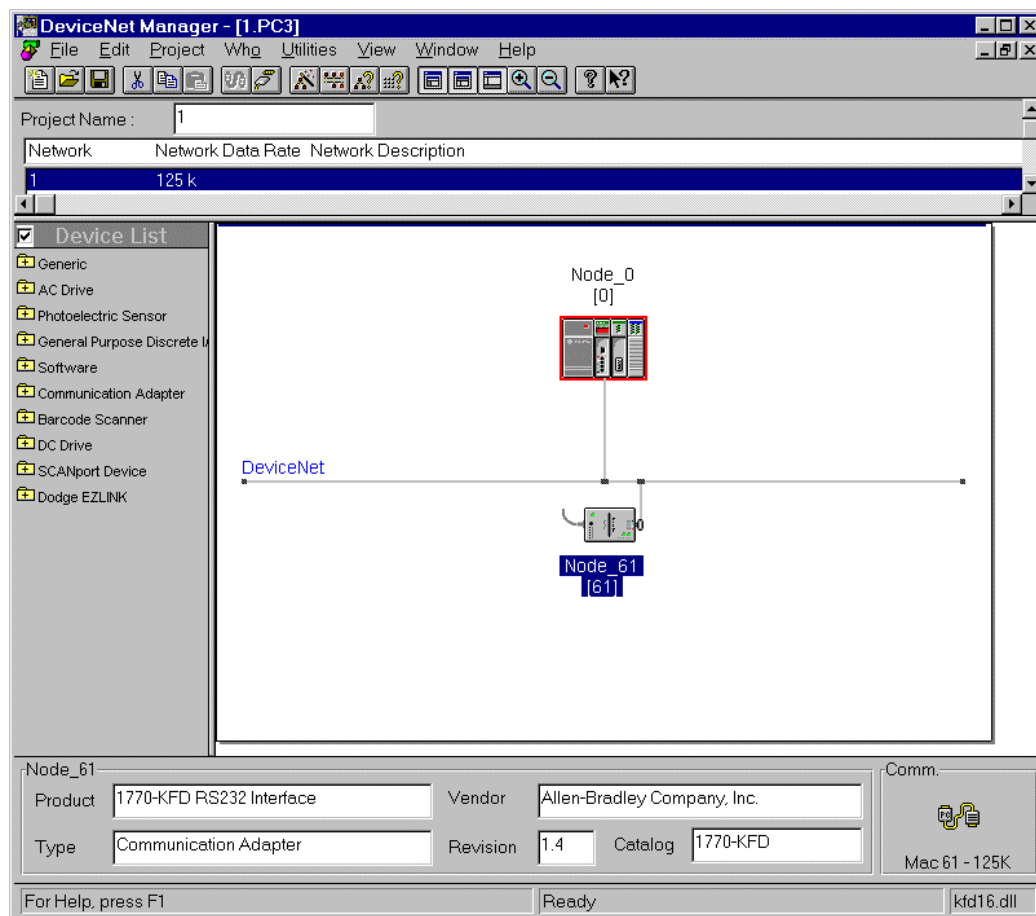

In this example, the device at Node_0 is a PLC with DeviceNet scanner, and Node_61 is a serial link to DeviceNet adapter.

Placing a 590+ Drive on to the Network

Double click on DC Drive in the Device List on the left hand side of the screen. If the 590P EDS file has been installed, Eurotherm will be listed as a supplier of DC drives (it may be listed as Eurotherm Controls Limited). Double click on Eurotherm, and 590+ should be listed. Click on 590+, and drag it into the main DeviceNet window. The following dialogue box appears:

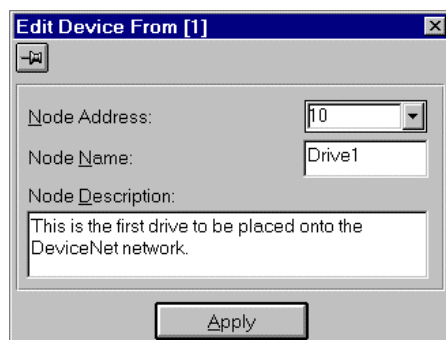

Edit the Node Address (i.e. the MAC ID), Node Name and Node Description. Node Address must be equal to the MAC ID you set in the drive configuration, as on page 50. Node Name and Node Description can be any meaningful text. Node Name will appear in the main

DeviceNet Manager window next to the drive after it has been placed onto it, and Node Description is comment text. Click Apply when you have finished editing these boxes.

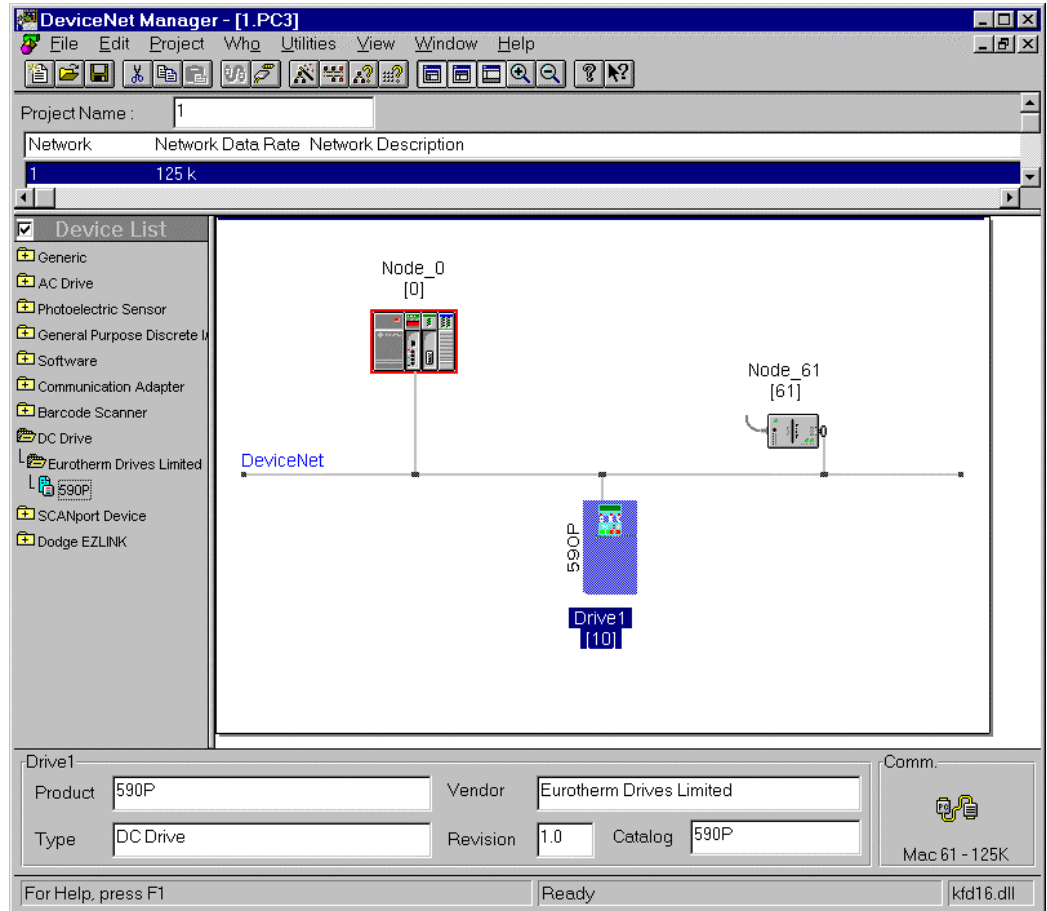

The drive is now registered on the DeviceNet network.

Connecting a Drive to a Scanner

This section will describe how to tell the scanner module about the 590+ drive, and how to make a polled I/O connection to it using the assembly objects defined earlier. The example screen shots were taken from a SLC-500 PLC from Allen-Bradley.

Double click on the icon for PLC, in this example it's at Node_0. The following dialogue box appears.

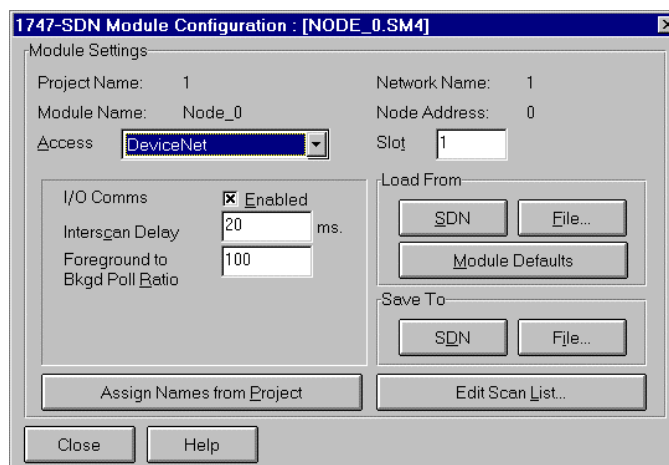

Click on Edit Scan List :

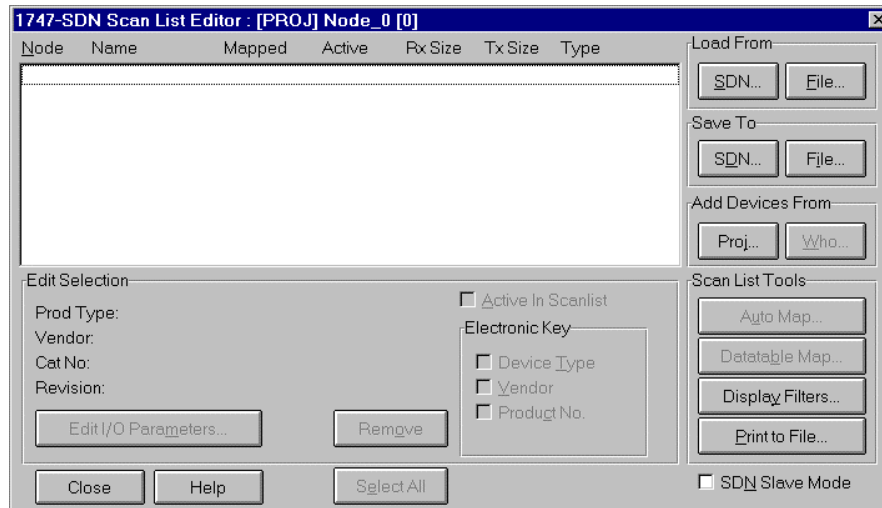

On the right hand side, click on Proj... in the Add Devices From region:

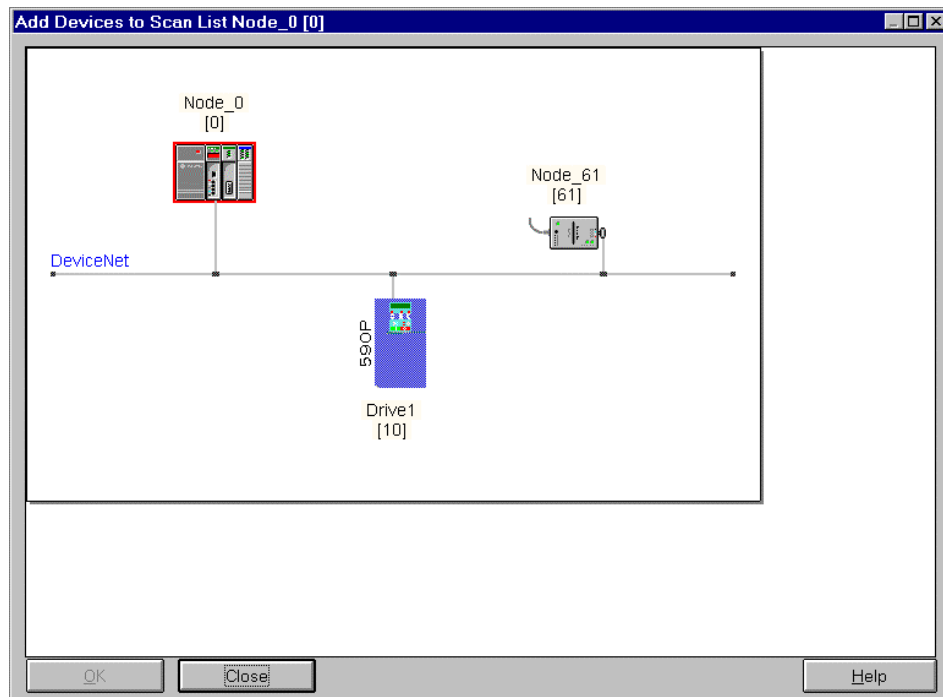

Click on the drive icon, Drive 1 and drag it onto Node_0. A box appears round Drive 1. Then click **OK**:-

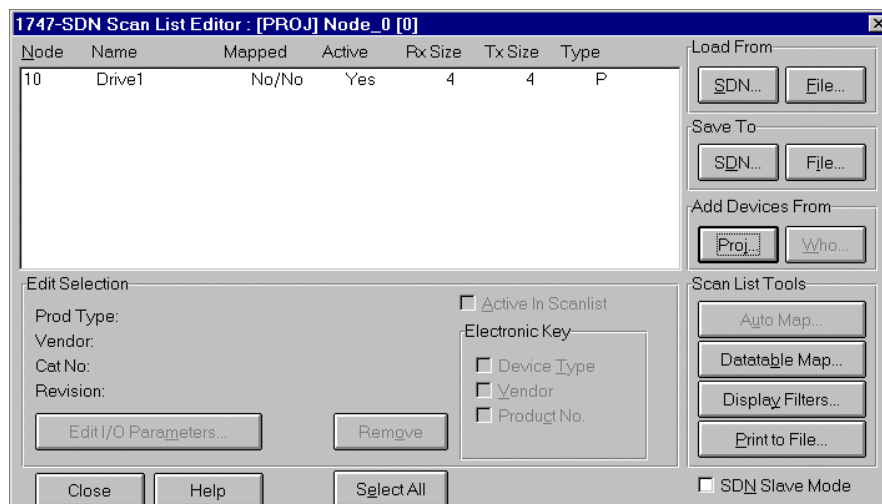

Note that the entry for the 590+ drive is identified by the Node Name we gave it earlier, i.e. Drive 1. Highlight the entry for Drive 1 in the main window area by clicking anywhere in the entry, and then click Edit I/O Parameters:

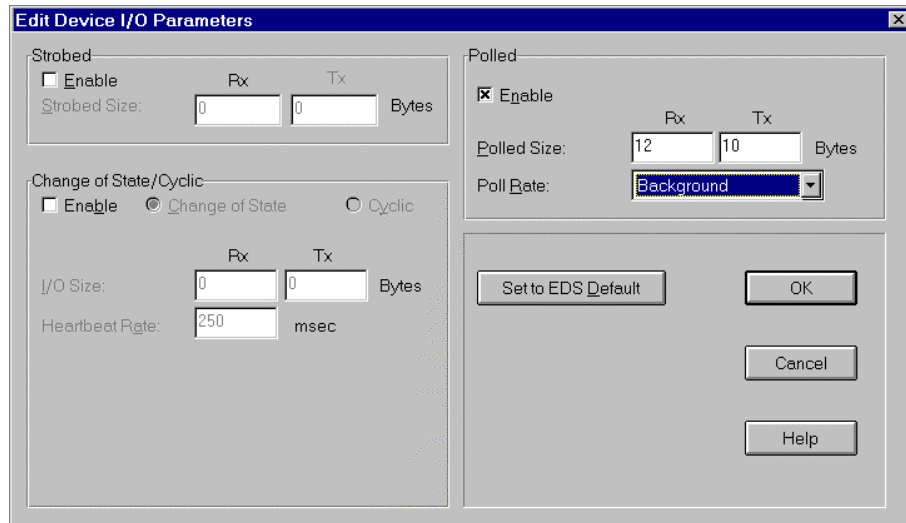

This example will set up a polled I/O messaging scheme. To enable it, ensure that the **Enable** box is checked in the **Polled** region, as shown.

This example will set up the scanner to use assembly object instances 0x66 and 0x71. Instance 0x61 writes 10 bytes to the drive, and instance 0x71 reads 12 bytes from it. Enter 12 in the **Rx** box, and 10 in the **Tx** box as shown.

The rate at which data are transferred between drive and PLC can be configured. If you have only a small amount of data, and timing is critical, you can transfer it on every PLC scan. If you have more data, and timing is not critical, it may be better to transfer data as a background task. The decision will also depend on how fast your PLC is, and how big its ladder program is. This example sets it to run in background mode. Select **Background** in the **Poll Rate** box as shown.

Now click **OK**:

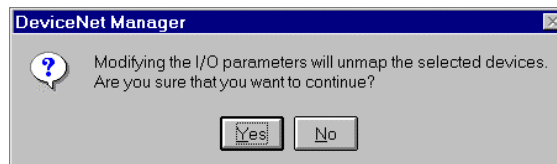

In Polled I/O operation, data are transferred directly to and from I/O image in the PLC. If you have a large amount of data, it may be possible to transfer via files instead, but this feature is not covered here. The next step will tell the PLC which registers the PLC will use to transfer to and from. This process is called mapping. The dialogue box tells us that we have just changed the number of registers that the PLC needs to reserve for the 590+, so we have to confirm that we want to proceed. Click **Yes**:

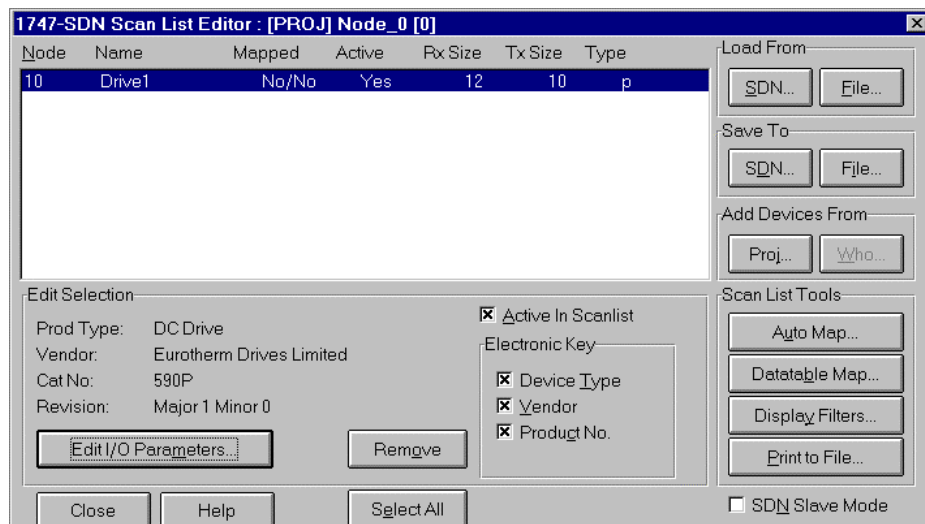

In the Scan List Tools region at the bottom right, click **Auto Map**:

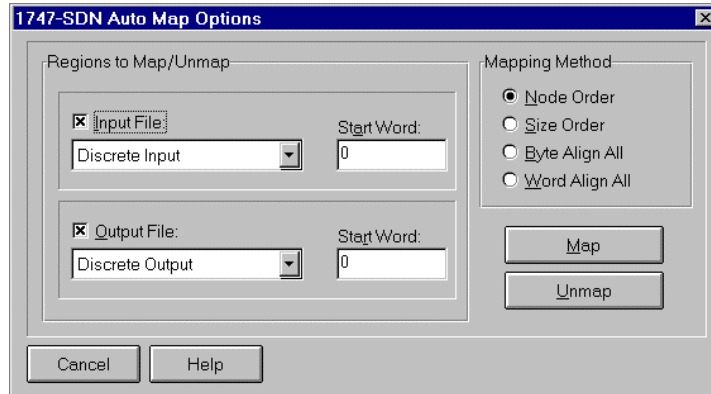

It is at this stage that we could elect to transfer data files instead of directly to and from I/O image. This example will transfer data to and from I/O image, so there is no need to change anything from the default values provided. Click **Map**.

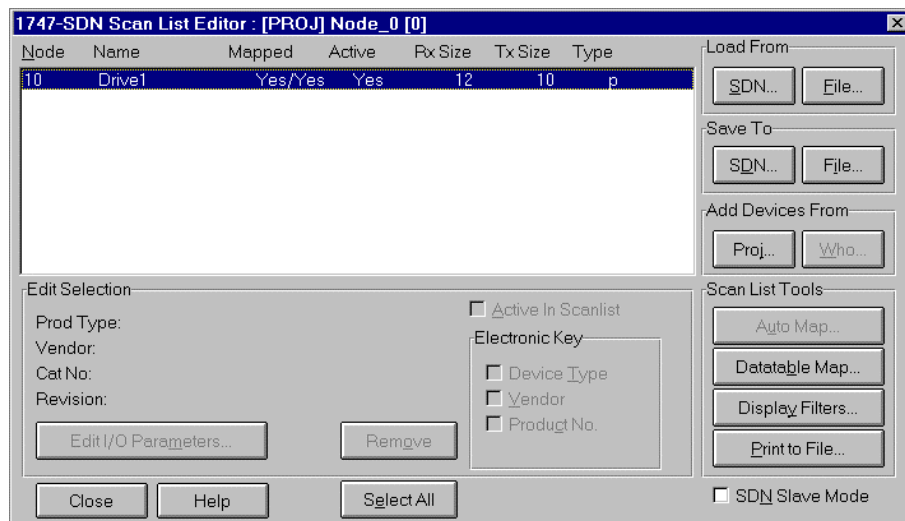

This dialog box shows us that Drive 1 has been mapped, indicated by Yes/Yes in the Mapped column of the main window.

If you wish to see how DeviceNet Manager has mapped its I/O image, click on **Datatable Map**:

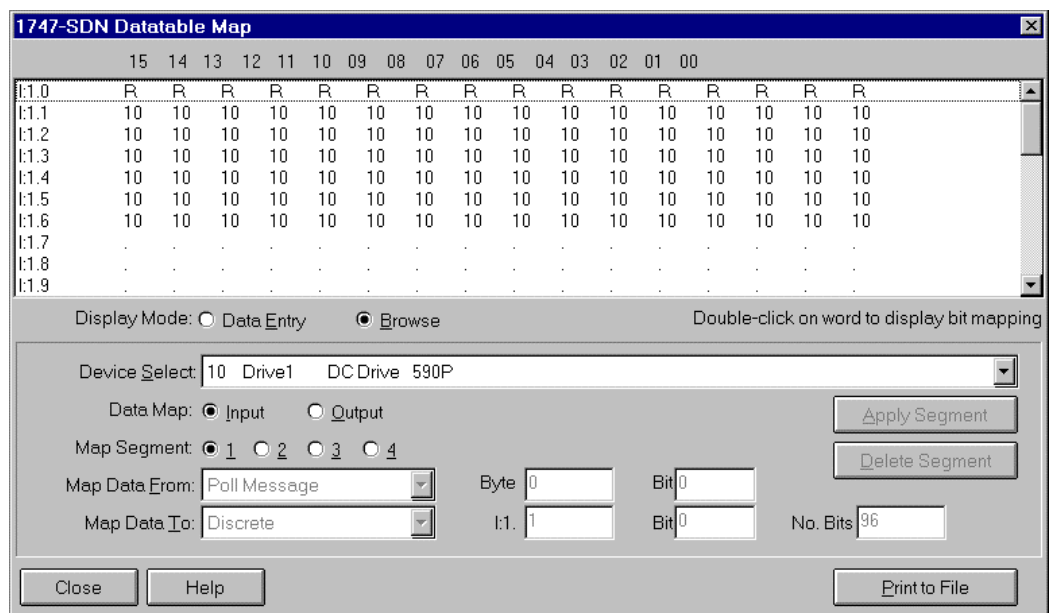

This shows that the PLC will put data from the device at address 10 (the 590+) into registers I:1.1 to I:1.6. Referring to the definition for instance 0x71 on page 44, we can see how the drive parameters are mapped into PLC registers:

PLC Register	Drive Parameter Name	Drive Tag No.
I:1.1	Sequence Status	537
I:1.2 Bit 0	miniLINK logic 5	350
I:1.2 Bit 1	miniLINK logic 6	351
I:1.2 Bit 2	miniLINK logic 7	352
I:1.2 Bit 3	miniLINK logic 8	353
I:1.3	Health Store Word	116
I:1.4	Speed Feedback %	207
I:1.5	miniLINK value 6	344
I:1.6	miniLINK value 7	345

Clicking on the Output button will show how the output registers have been mapped.

Click **C**lose to dismiss this dialogue box.

Now we have to download this configuration into the PLC itself. On the right hand side, click on **S**DN in the **S**ave **T**o region.

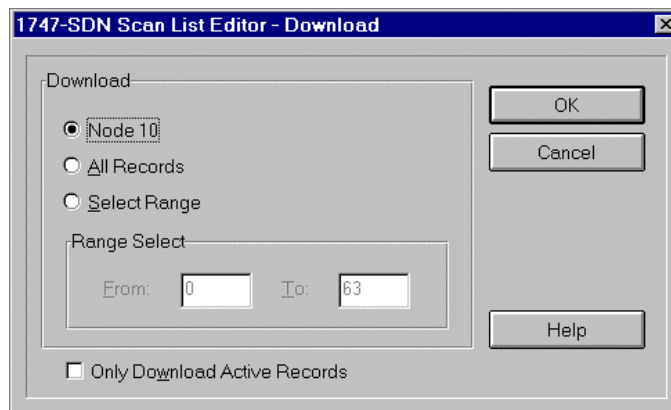

You can select which nodes (MAC IDs) you need to tell the PLC about. If you have changed only one node, select it (the example shows just **N**ode **10** selected). If you are not sure, it's safest to click **A**ll **R**ecords. Ensure that your PLC is set to receive an update. On a SLC-500 for example, this requires the keyswitch to be set to PROG. Then click **O**K in the dialogue box.

You should now save your PLC configuration onto your computer. So click **C**lose, and then follow the familiar file save procedure. After you have done this, the following dialogue box re-appears:

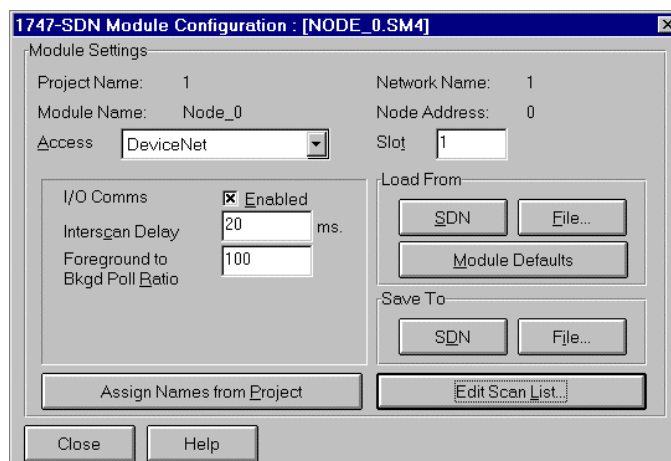

As we selected data should be transferred in background, this dialogue box lets us define how frequently the data should be transferred. The example shows an **InterScan Delay** of 20ms, and a **Foreground to Bkgd Poll Ratio** of 100. This means that the background tasks will run 100 times slower than the scan rate. In this example, data will be transferred to and from the drive every 2 seconds. Click on **SDN** in the **Save To** region.

When download is complete, set the PLC into RUN mode again, and it now starts transferring data with the drive, at the frequency we specified.

Click **Close** and save the configuration again when prompted. Configuration is now complete.

Referring to the datatable map on page

Configuring RsNetWorx for DeviceNet

This example will repeat the previous configuration, which used DeviceNet Manager, but will use RsNetWorx for DeviceNet instead.

A starting point could be something like this:

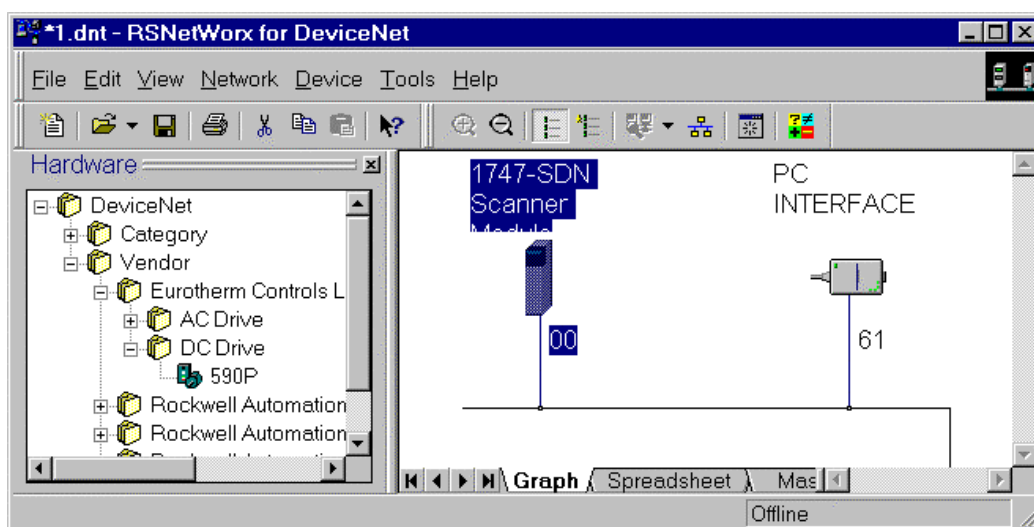

This shows just a 1747-SDN scanner module at node address 00, and a serial interface to a PC connected onto the network at node address 61.

Placing a 590+ Drive on to the Network

First, we need to add a drive onto the network. We will choose a 590+ again. From the Hardware list on the left, locate 590+. You can either choose by Category (choose DC drive first, then 590+) or by Vendor (choose Eurotherm first, then 590+). Having located 590+, double click on it. An icon for a 590+ appears on the network:

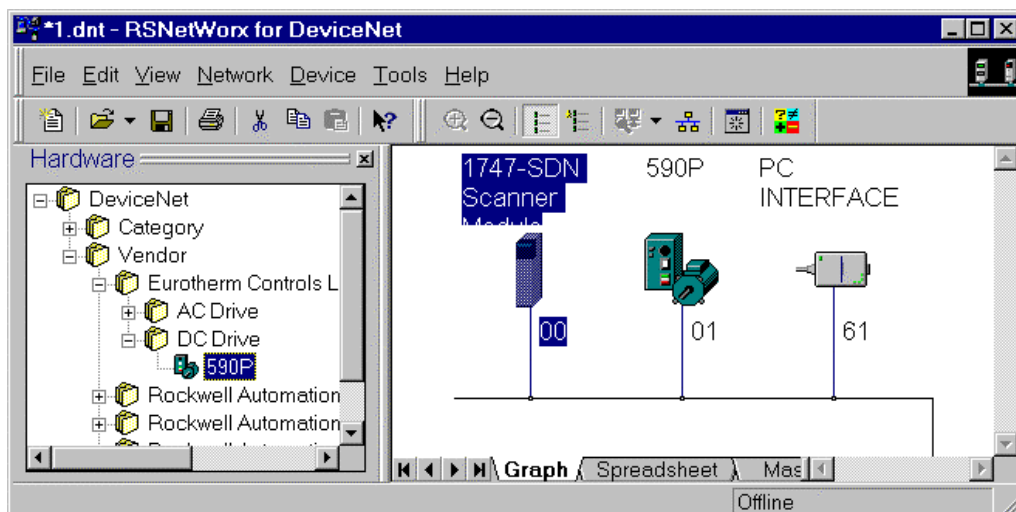

Note that the 590+ is assigned the first available node address (01). If you wish to change it, make sure you are offline, and then double click on the 590+ icon. A dialogue box appears which allows you to change it, and also to add a description for the drive.

Connecting a Drive to a Scanner

Next, we have to make a connection between the scanner and the drive. Double click on the scanner icon:

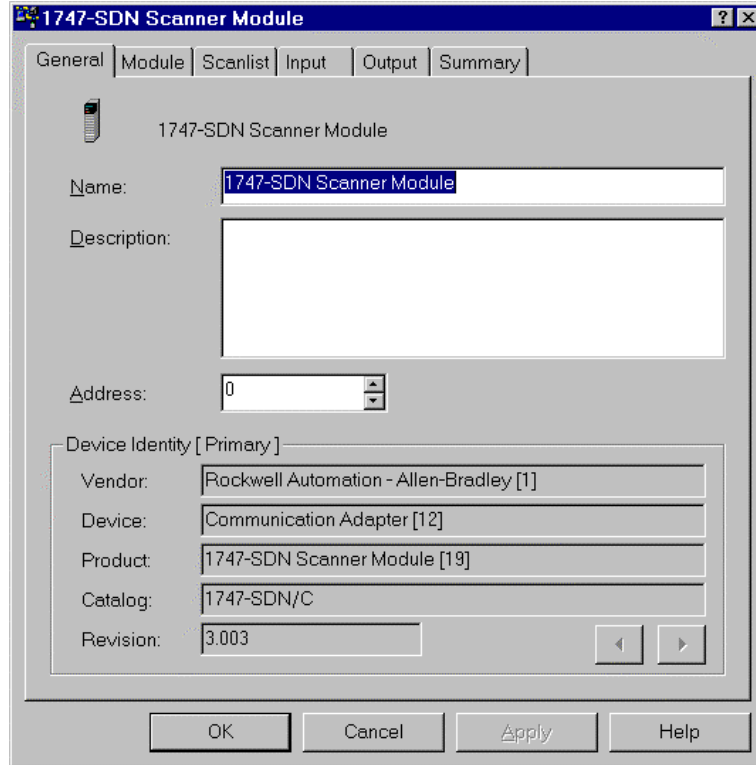

Now click on the Scanlist tab:

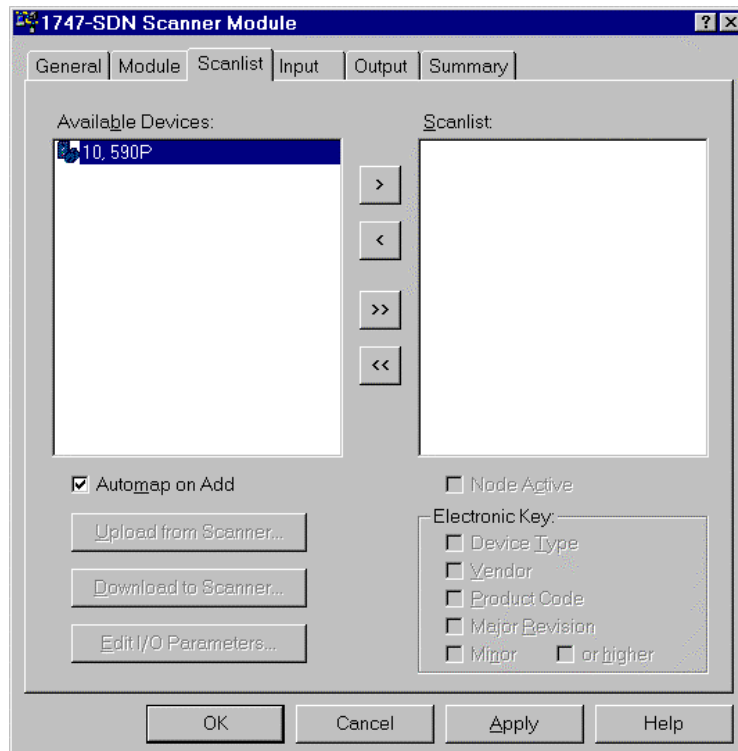

The left-hand window shows a list of devices which can be connected, the right-hand window shows the list of devices currently connected. The example shows just the 590+ is available, and no devices are currently in the scanlist. To connect the 590+ at address 10, select it, as shown, and then click on the > symbol. The 590+ moves to the right-hand window:

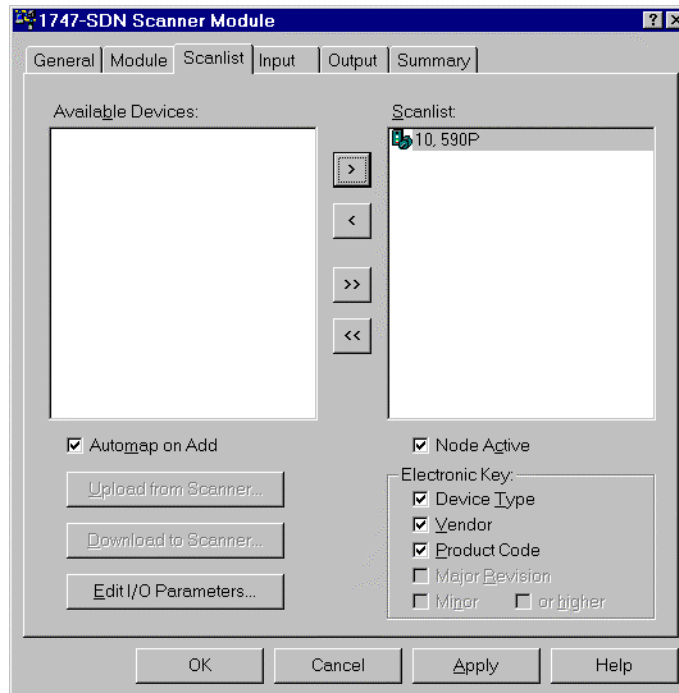

Next we have to tell the program how many bytes will be transferred in each direction. Highlight the 590+ by clicking on it, and then click Edit I/O Parameters:

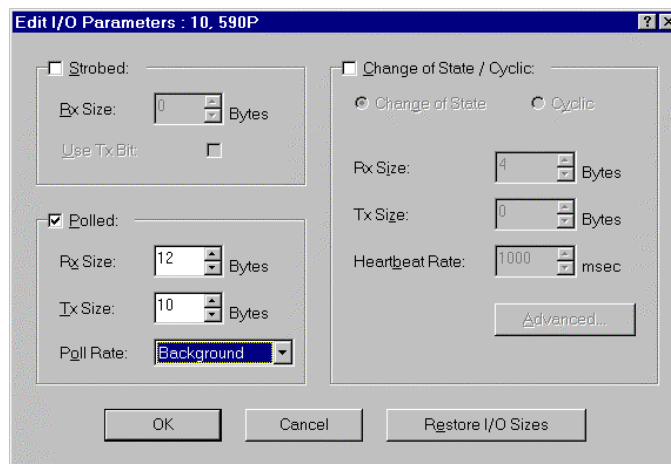

To use Polled I/O, ensure the Polled box is checked, as shown.

This example will set up the scanner to use assembly object instances 0x66 and 0x71. Instance 0x66 writes 10 bytes to the drive, and instance 0x71 reads 12 bytes from it. So enter 12 in the Rx Size box in the Polled, and 10 in the Tx Size box as shown.

Also select Poll Rate to be Background, as shown (refer to page 54 for a brief discussion on this feature). Then click OK.

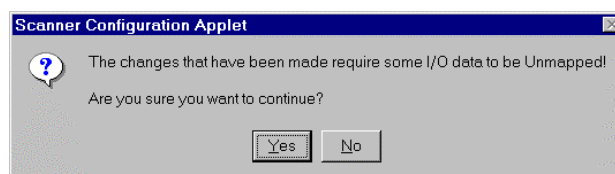

In Polled I/O operation, data is transferred directly to and from I/O image in the PLC. If you have a large amount of data, it may be possible to transfer via files instead, but this feature is not covered here. The next step will tell the PLC which registers the data will be transferred to and from. This process is called mapping. The dialogue box tells us that we have just changed the

number of registers that the PLC needs to reserve for the 590+, so we have to confirm that we want to procede. Click Yes.

We now return to a previous dialogue box, from where we will set up the I/O image mapping. Click on the Input tab:

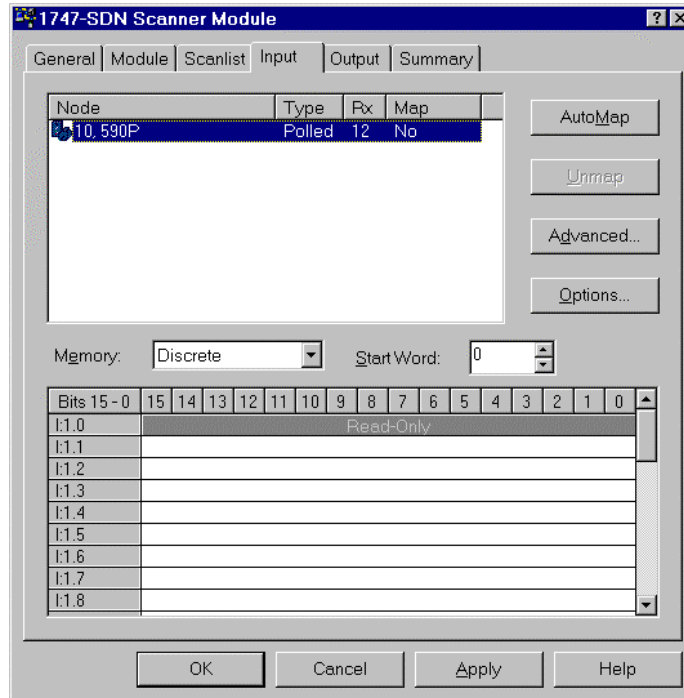

Ensure the 590+ at address 10 is highlighted by clicking on it if necessary, and then click AutoMap:

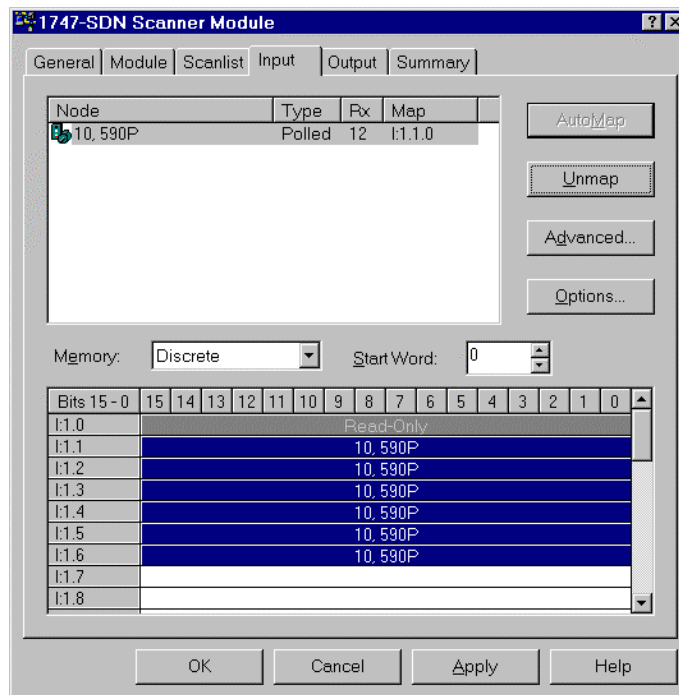

The window at the bottom of the screen shows how RsNetWorx has mapped the input registers into which it will put data from the 590+. Refer to the table on page 56 which shows a cross reference between PLC input registers and drive tags for this example. Now click on the Ouput tab, and repeat this process to set up the output registers which will be the source of data sent to the 590+.

As in the DeviceNet Manager example, we now have to set up the scan rate. Click on the Module tab:

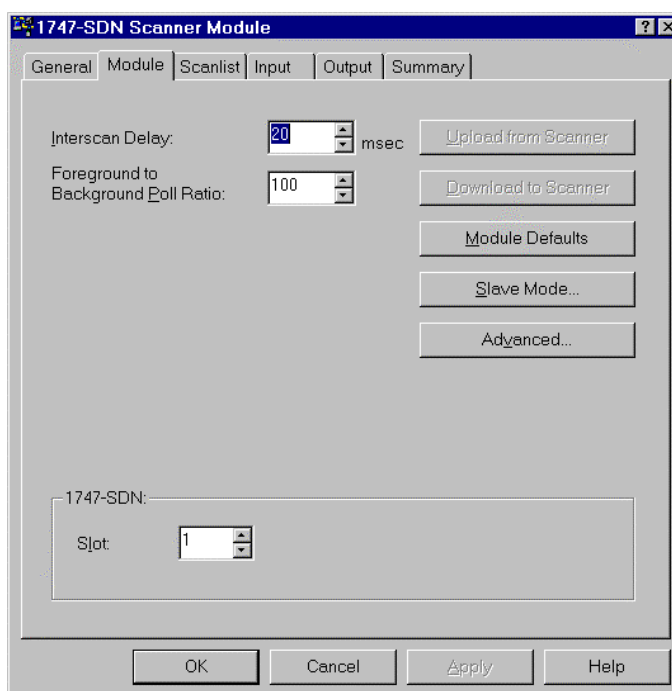

The example shows that the Interscan delay will be 20ms, that is the rate at which the PLC executes its ladder program, and the Foreground to Background Poll Ratio is 100. This means that the background tasks, which include communications to the 590+, will execute 100 times slower, i.e. every 2 seconds.

When you have finished, click OK.

Now we have to download the completed configuration into the PLC. Ensure that your PLC is set to receive an update. Using a SLC-500 for example, this requires the keyswitch to be set to

PROG. Then go online to the DeviceNet network by clicking the Online button: 

The system will scan the online network, and add a status flag against each device as appropriate. From the Network menu, select Download to Network. Confirm your decision when prompted, and then a status indicator will show download progress:

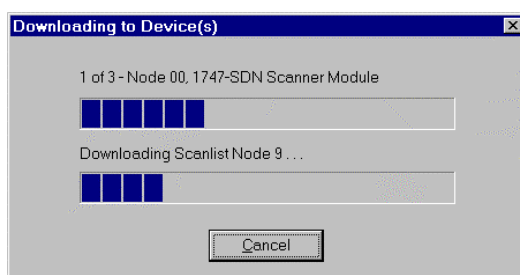

When download is complete, the PLC will save the new configuration. Then you can switch it to RUN, and data will start being transferred between PLC and drive. Configuration is now complete.

Fault Detection

In many applications, it may be necessary to detect DeviceNet network faults and take appropriate action, for example, stop the drive. The following sections describe how to achieve this. The floppy disk provided with this manual contains some ConfigEd Lite files which can be used to get started.

590+

This section describes how to cause a 590+ to stop if the DeviceNet network fails. The example assumes a polled I/O connection is established, and the drive will stop if the network is broken.

The CONNXN STATUS function block output indicates the health or otherwise of the connection to the master device. For example, if a polled I/O connection is established, the value

will be 0x0033 or 0x0035 in normal operation. Other values indicate that communication has either not been established, or it has failed.

DeviceNet Technology Options detect loss of communication by means a time-out. This makes use of the Expected Packet Rate (EPR) attribute. The EPR of a device is accessible through the explicit connection to the DeviceNet Connection Object, see page 21. Normally a master device will write to this attribute during establishment of a connection, and it will often be accessible through the configuration tool for the DeviceNet master.

The EPR value is usually set to the normal scan rate of the master device, and the Technology Option will detect a time-out if no data is received from the DeviceNet master for 4 times the EPR.

Connect function blocks as shown:

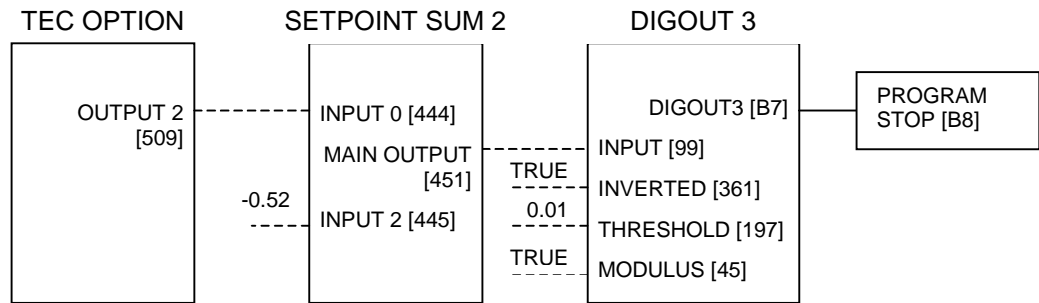

Connections shown as dashed are software links in the 590+. The solid connection between DIGOUT3 and PROGRAM STOP is a hardware link between user control terminals.

This operates as follows:

TEC OPTION output 2 is the CONNXN STATUS value, which is 0x0033 or 0x0035 in normal operation. These values are represented internally to the drive as 0.51 and 0.53 respectively.

In Setpoint Sum 2, 0.52 is subtracted from the CONNXN STATUS value, so the normal operating values at MAIN OUTPUT are -0.01 and +0.01.

In Digout3, the modulus is taken, so the normal operating value is now +0.01 only. It is compared with a threshold of +0.01, and if it is greater the output DIGOUT3 goes FALSE. Otherwise it is TRUE. In other words, DIGOUT3 is TRUE when CONNXN STATUS is in one of the normal operating states, and is FALSE otherwise.

DIGOUT3 connects to the PROGRAM STOP input, so this input is TRUE if connection to the DeviceNet master is healthy, and goes FALSE if the connection is broken, and therefore the drive will stop.

This method is implemented in the 590+ ConfigEd Lite files provided with this manual.

690+

Two methods of detecting loss of communications are available in Eurotherm Drives AC products which include 690+, 605 and 584SV. The choice depends on which assembly numbers are chosen.

Assembly Instance 0x69

This method uses functionality built in to the drive. It can be used only if write assembly instance 0x69 is chosen because this is the only one that writes to tag 271, the Comms Command value.

In the drive's Comms Control function block there is a timeout value, tag 309. If the value is non-zero, the drive will detect if DeviceNet network activity stops, and will stop the drive after the timeout period specified. For more information refer to the Comms Control function block in the drive's product manual.

This method is implemented in the dnet4669.xxx ConfigEd Lite files supplied with this manual.

Other Assembly Instances

This method must be used if the assembly instance number is not 0x69.

Connect function blocks as shown:

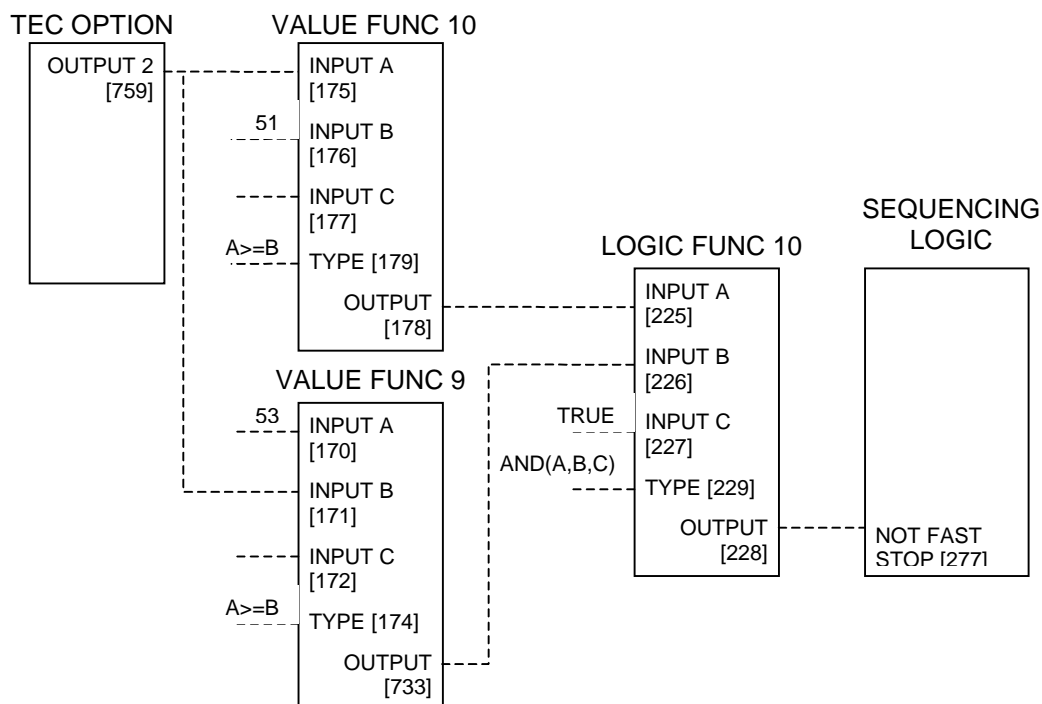

Connections shown as dashed are software links in the 690+.

This operates as follows:

TEC OPTION output 2 is the CONNXN STATUS value, which is 0x0033 or 0x0035 in normal operation. These values are represented internally to the drive as 51 and 53 respectively.

VALUE FUNC 10 compares Output 2 from the TEC OPTION with value 51. If it is greater, than or equal, its output is TRUE. Otherwise it is FALSE.

VALUE FUNC 9 compares Output 2 from the TEC OPTION with value 53. If it is less than, or equal, its output is TRUE. Otherwise it is FALSE.

The output from LOGIC FUNC 10 is TRUE if all its inputs are TRUE. That is, if CONNXN STATUS is greater than, or equal to, 51 and less than, or equal to, 53.





The output from LOGIC FUNC 10 connects into an appropriate input of the SEQUENCING LOGIC, in this case the Fast Stop input.

This method is implemented in ConfigEd Lite files dnet4614.xxx for AC products supplied with this manual.







LED Indicators

Two LEDs report the status of the DeviceNet Technology Option and the network, which operate independently.









LED states in the following tables are indicated thus:

-  LED is off
-  LED is mostly off and flashes on briefly
-  LED flashes with equal on and off times
-  LED is mostly on and flashes off briefly
-  LED is on

Module LED

MODULE LED	Cause / Symptom	Remedy
	No power at the drive.	Check and apply power to the drive.
	Technology Box not installed correctly.	Check connections between Technology Box and drive. On 605A & B, check the ribbon cable.
	MAC ID set to 0	Set the MAC ID to a non-zero value. Remember to toggle REFRESH INPUTS (TRUE to FALSE) afterwards.
	Hardware fault. 605A & B WARNING: Remove the terminal cover and the Technology Box whilst connected to see the drive's HEALTH and RUN LEDs. BEWARE OF ELECTRIC SHOCK.	If HEALTH and RUN LEDs are OFF, replace the drive, else replace the Technology Box/Option.
	Incorrect Technology Box fitted or selected.	Fit the correct Technology Box or select the matching value for the TYPE parameter in the TEC OPTION function block. (TYPE = DEVICENET). Remember to toggle REFRESH INPUTS (TRUE to FALSE) afterwards.
	Set-up fault. A TEC OPTION parameter is out-of-range.	Select the correct value for the parameter in the TEC OPTION function block. Remember to toggle REFRESH INPUTS (TRUE to FALSE) afterwards.
	Module is operating normally	No corrective action required.

Network LED

NETWORK	Cause/Symptom	Remedy
	Incorrect wiring.	Check wiring, verifying the continuity of CAN_L and CAN_H connections to the master, and ensure that the correct terminals have been used. Pay particular attention to the integrity of the screening.
	Incorrect baud rate.	Check the baud rate is the same as the master device. Remember to toggle REFRESH INPUTS (TRUE to FALSE) after changing the BAUD RATE.
	Maximum line length exceeded.	Ensure that the maximum line length of transmission line has not been exceeded for the Baud rate in use.
	Incorrect line terminations.	Ensure that the last unit on the transmission line is terminated correctly. Note that some equipment has built-in resistors that may be switched in and out of circuit.
	Invalid MAC ID.	Check the MAC ID. Check that it is not 0 and that there isn't another unit on the network with the same MAC ID. If you change the MAC ID, remember to toggle REFRESH INPUTS from TRUE to FALSE.
	Invalid configuration, or configuration not downloaded to master device.	Ensure that the network has been correctly configured and that the configuration has been correctly downloaded to the master.
	Device has been on-line, and has now gone off-line.	Check the drive has been allocated to a master, and initiate communications.
	Device is online but has no connection.	Check the drive has been allocated to a master, and initiate communications.
	The unit should now be working.	If there is still a problem, please check your Tag numbers.

Note: *Toggling REFRESH INPUTS from TRUE to FALSE can cause the drive to recover from many faults.*

Internal Diagnostics

Three parameters of the TEC OPTION function block provide diagnostic information:

TEC OPTION FAULT

This output identifies major faults in the internal interface between the Technology Option and the drive. Possible values are:

TEC OPTION FAULT	Cause	Remedy
NONE	The interface is operating normally.	None required.
PARAMETER	Invalid MAC ID or BAUD RATE.	Check that MAC ID is set to a valid value (from 1 to 63 inclusive), and BAUD RATE is set to a valid value (125K, 250K or 500K). Then toggle REFRESH INPUTS from TRUE to FALSE.
TYPE MISMATCH	The incorrect Technology Option is fitted, or the TEC OPTION TYPE is incorrect.	Install the correct Technology Option, or set TEC OPTION TYPE to DEVICENET. Then toggle REFRESH INPUTS from TRUE to FALSE.
HARDWARE	The drive detected a Technology Option, but could not establish communications with it.	Check that the Technology Option is installed correctly. If the fault persists, call Eurotherm Drives for technical support.
MISSING	The drive could not detect a Technology Option.	Install a DeviceNet Technology Option. If the fault persists, call Eurotherm Drives for technical support.

DEVICE STATUS

This output indicates the status of the technology option. Possible values are :

DEVICE STATUS	Cause	Remedy
0000	Off line	Device is operational, but no connection has been established with a master.
0004	Technology Box has been configured, but has not been assigned to a DeviceNet master.	Configure the DeviceNet master to make a connection to the drive.
0004	Incorrect baud rate selected	Select the correct baud rate, then toggle REFRESH INPUTS true then false.
0005	Technology Box is in normal operating mode.	None required. This value indicates that the Technology Box is communicating to the DeviceNet master.
010x	Drive and Technology Box mismatch.	Select TEC OPTION TYPE = DEVICENET. Then toggle REFRESH INPUTS true then false.
0804	Duplicate MAC ID	Select a unique MAC ID, then toggle REFRESH INPUTS true then false.

CONNXXN STATUS

CONNXXN STATUS	Cause	Remedy
0000	No connections established.	Establish a connection
0001	Explicit connection is being established.	None required. This is a normal transitory condition during the establishment of a connection.
0002	Explicit connection is waiting for a connection ID.	None required. This is a normal transitory condition during the establishment of a connection.
0003	Explicit connection is established.	None. This is the normal condition during an explicit-only connection.
0004	Explicit connection timed out.	DeviceNet Master failed to communicate with the TechBox within 4 times the EPR (Expected Packet Rate).
0013	Polled I/O connection is being established.	None required. This is a normal transitory condition during the establishment of a polled I/O connection.
0023	Polled I/O connection is waiting for a connection ID.	None required. This is a normal transitory condition during the establishment of a polled I/O connection.
0033	Polled I/O connection is established.	None required. This is the normal state for a polled I/O connection.
0035	Polled I/O connection is established, and explicit connection is in Deferred Delete state.	None required. This can be a normal condition, depending on how the master device configures the TechBox. It will occur if it doesn't disable explicit messaging timeout.
004x	Polled I/O connection timed out.	The TechBox failed to receive a Polled I/O message from the host within 4 times the EPR. Check the wiring is intact, the cable is terminated correctly, and the master is still functional.
0103	Cyclic connection is configuring.	None required. This is a normal transitory condition during the establishment of a cyclic connection.
0203	Cyclic connection is waiting for a connection ID.	None required. This is a normal transitory condition during the establishment of a cyclic connection.
0303	Cyclic connection is established.	None required. This is the normal state for a cyclic connection.
0305	Cyclic connection is established, and explicit connection is in Deferred Delete state.	None required. This can be a normal condition, depending on how the master device configures the TechBox. It will occur if it doesn't disable explicit messaging timeout.

Decimal/Hexadecimal Table

	0	1	2	3	4	5	6	7	8	9
0	0000	0001	0002	0003	0004	0005	0006	0007	0008	0009
10	000A	000B	000C	000D	000E	000F	0010	0011	0012	0013
20	0014	0015	0016	0017	0018	0019	001A	001B	001C	001D
30	001E	001F	0020	0021	0022	0023	0024	0025	0026	0027
40	0028	0029	002A	002B	002C	002D	002E	002F	0030	0031
50	0032	0033	0034	0035	0036	0037	0038	0039	003A	003B
60	003C	003D	003E	003F	0040	0041	0042	0043	0044	0045
70	0046	0047	0048	0049	004A	004B	004C	004D	004E	004F
80	0050	0051	0052	0053	0054	0055	0056	0057	0058	0059
90	005A	005B	005C	005D	005E	005F	0060	0061	0062	0063
100	0064	0065	0066	0067	0068	0069	006A	006B	006C	006D
110	006E	006F	0070	0071	0072	0073	0074	0075	0076	0077
120	0078	0079	007A	007B	007C	007D	007E	007F	0080	0081
130	0082	0083	0084	0085	0086	0087	0088	0089	008A	008B
140	008C	008D	008E	008F	0090	0091	0092	0093	0094	0095
150	0096	0097	0098	0099	009A	009B	009C	009D	009E	009F
160	00A0	00A1	00A2	00A3	00A4	00A5	00A6	00A7	00A8	00A9
170	00AA	00AB	00AC	00AD	00AE	00AF	00B0	00B1	00B2	00B3
180	00B4	00B5	00B6	00B7	00B8	00B9	00BA	00BB	00BC	00BD
190	00BE	00BF	00C0	00C1	00C2	00C3	00C4	00C5	00C6	00C7
200	00C8	00C9	00CA	00CB	00CC	00CD	00CE	00CF	00D0	00D1
210	00D2	00D3	00D4	00D5	00D6	00D7	00D8	00D9	00DA	00DB
220	00DC	00DD	00DE	00DF	00E0	00E1	00E2	00E3	00E4	00E5
230	00E6	00E7	00E8	00E9	00EA	00EB	00EC	00ED	00EE	00EF
240	00F0	00F1	00F2	00F3	00F4	00F5	00F6	00F7	00F8	00F9
250	00FA	00FB	00FC	00FD	00FE	00FF	0100	0101	0102	0103
260	0104	0105	0106	0107	0108	0109	010A	010B	010C	010D
270	010E	010F	0110	0111	0112	0113	0114	0115	0116	0117
280	0118	0119	011A	011B	011C	011D	011E	011F	0120	0121
290	0122	0123	0124	0125	0126	0127	0128	0129	012A	012B
300	012C	012D	012E	012F	0130	0131	0132	0133	0134	0135
310	0136	0137	0138	0139	013A	013B	013C	013D	013E	013F
320	0140	0141	0142	0143	0144	0145	0146	0147	0148	0149
330	014A	014B	014C	014D	014E	014F	0150	0151	0152	0153
340	0154	0155	0156	0157	0158	0159	015A	015B	015C	015D
350	015E	015F	0160	0161	0162	0163	0164	0165	0166	0167
360	0168	0169	016A	016B	016C	016D	016E	016F	0170	0171
370	0172	0173	0174	0175	0176	0177	0178	0179	017A	017B
380	017C	017D	017E	017F	0180	0181	0182	0183	0184	0185
390	0186	0187	0188	0189	018A	018B	018C	018D	018E	018F
400	0190	0191	0192	0193	0194	0195	0196	0197	0198	0199
410	019A	019B	019C	019D	019E	019F	01A0	01A1	01A2	01A3
420	01A4	01A5	01A6	01A7	01A8	01A9	01AA	01AB	01AC	01AD
430	01AE	01AF	01B0	01B1	01B2	01B3	01B4	01B5	01B6	01B7
440	01B8	01B9	01BA	01BB	01BC	01BD	01BE	01BF	01C0	01C1
450	01C2	01C3	01C4	01C5	01C6	01C7	01C8	01C9	01CA	01CB
460	01CC	01CD	01CE	01CF	01D0	01D1	01D2	01D3	01D4	01D5
470	01D6	01D7	01D8	01D9	01DA	01DB	01DC	01DD	01DE	01DF
480	01E0	01E1	01E2	01E3	01E4	01E5	01E6	01E7	01E8	01E9
490	01EA	01EB	01EC	01ED	01EE	01EF	01F0	01F1	01F2	01F3

Decimal/Hexadecimal Table

	0	1	2	3	4	5	6	7	8	9
500	01F4	01F5	01F6	01F7	01F8	01F9	01FA	01FB	01FC	01FD
510	01FE	01FF	0200	0201	0202	0203	0204	0205	0206	0207
520	0208	0209	020A	020B	020C	020D	020E	020F	0210	0211
530	0212	0213	0214	0215	0216	0217	0218	0219	021A	021B
540	021C	021D	021E	021F	0220	0221	0222	0223	0224	0225
550	0226	0227	0228	0229	022A	022B	022C	022D	022E	022F
560	0230	0231	0232	0233	0234	0235	0236	0237	0238	0239
570	023A	023B	023C	023D	023E	023F	0240	0241	0242	0243
580	0244	0245	0246	0247	0248	0249	024A	024B	024C	024D
590	024E	024F	0250	0251	0252	0253	0254	0255	0256	0257
600	0258	0259	025A	025B	025C	025D	025E	025F	0260	0261
610	0262	0263	0264	0265	0266	0267	0268	0269	026A	026B
620	026C	026D	026E	026F	0270	0271	0272	0273	0274	0275
630	0276	0277	0278	0279	027A	027B	027C	027D	027E	027F
640	0280	0281	0282	0283	0284	0285	0286	0287	0288	0289
650	028A	028B	028C	028D	028E	028F	0290	0291	0292	0293
660	0294	0295	0296	0297	0298	0299	029A	029B	029C	029D
670	029E	029F	02A0	02A1	02A2	02A3	02A4	02A5	02A6	02A7
680	02A8	02A9	02AA	02AB	02AC	02AD	02AE	02AF	02B0	02B1
690	02B2	02B3	02B4	02B5	02B6	02B7	02B8	02B9	02BA	02BB
700	02BC	02BD	02BE	02BF	02C0	02C1	02C2	02C3	02C4	02C5
710	02C6	02C7	02C8	02C9	02CA	02CB	02CC	02CD	02CE	02CF
720	02D0	02D1	02D2	02D3	02D4	02D5	02D6	02D7	02D8	02D9
730	02DA	02DB	02DC	02DD	02DE	02DF	02E0	02E1	02E2	02E3
740	02E4	02E5	02E6	02E7	02E8	02E9	02EA	02EB	02EC	02ED
750	02EE	02EF	02F0	02F1	02F2	02F3	02F4	02F5	02F6	02F7
760	02F8	02F9	02FA	02FB	02FC	02FD	02FE	02FF	0300	0301
770	0302	0303	0304	0305	0306	0307	0308	0309	030A	030B
780	030C	030D	030E	030F	0310	0311	0312	0313	0314	0315
790	0316	0317	0318	0319	031A	031B	031C	031D	031E	031F
800	0320	0321	0322	0323	0324	0325	0326	0327	0328	0329
810	032A	032B	032C	032D	032E	032F	0330	0331	0332	0333
820	0334	0335	0336	0337	0338	0339	033A	033B	033C	033D
830	033E	033F	0340	0341	0342	0343	0344	0345	0346	0347
840	0348	0349	034A	034B	034C	034D	034E	034F	0350	0351
850	0352	0353	0354	0355	0356	0357	0358	0359	035A	035B
860	035C	035D	035E	035F	0360	0361	0362	0363	0364	0365
870	0366	0367	0368	0369	036A	036B	036C	036D	036E	036F
880	0370	0371	0372	0373	0374	0375	0376	0377	0378	0379
890	037A	037B	037C	037D	037E	037F	0380	0381	0382	0383
900	0384	0385	0386	0387	0388	0389	038A	038B	038C	038D
910	038E	038F	0390	0391	0392	0393	0394	0395	0396	0397
920	0398	0399	039A	039B	039C	039D	039E	039F	03A0	03A1
930	03A2	03A3	03A4	03A5	03A6	03A7	03A8	03A9	03AA	03AB
940	03AC	03AD	03AE	03AF	03B0	03B1	03B2	03B3	03B4	03B5
950	03B6	03B7	03B8	03B9	03BA	03BB	03BC	03BD	03BE	03BF
960	03C0	03C1	03C2	03C3	03C4	03C5	03C6	03C7	03C8	03C9
970	03CA	03CB	03CC	03CD	03CE	03CF	03D0	03D1	03D2	03D3
980	03D4	03D5	03D6	03D7	03D8	03D9	03DA	03DB	03DC	03DD
990	03DE	03DF	03E0	03E1	03E2	03E3	03E4	03E5	03E6	03E7