



**EUROTHERM
DRIVES**

**584S/620
TYPE 8, 9 & 10**

Addendum

© Copyright Eurotherm Drives Limited 1999

All rights strictly reserved. No part of this document may be stored in a retrieval system, or transmitted in any form or by any means to persons not employed by a Eurotherm group company without written permission from Eurotherm Drives Ltd.

Although every effort has been taken to ensure the accuracy of this document it may be necessary, without notice, to make amendments or correct omissions. Eurotherm Drives cannot accept responsibility for damage, injury, or expenses resulting therefrom.

WARRANTY

Eurotherm Drives warrants the goods against defects in design, materials and workmanship for the period of 12 months from the date of delivery on the terms detailed in Eurotherm Drives Standard Conditions of Sale IA058393C.

Eurotherm Drives reserves the right to change the content and product specification without notice.

© COPYRIGHT in this document is reserved to Eurotherm Drives Ltd.

INTENDED USERS

This manual is to be made available to all persons who are required to configure, install or service the equipment described herein or any other associated operation.

**584S/620
TYPE 8, 9 & 10**

Contents

Chapter 1 Manual Scope	1-1
DESCRIPTION	1-1
PRODUCT RANGE	1-1
EQUIPMENT SUPPLIED	1-1
COMPONENT IDENTIFICATION	1-2
INSTALLATION WIRING DIAGRAMS	1-3
BLOCK DIAGRAM 8, 9 & 10.....	1-3
TERMINAL DESCRIPTIONS.....	1-3
TERMINATIONS	1-6
Chapter 2 Technical Specification	2-1
GENERAL.....	2-1
ELECTRICAL RATINGS - POWER CIRCUITS (620/584S CONSTANT TORQUE).....	2-1
ELECTRICAL RATINGS - POWER CIRCUIT (584S QUADRATIC TORQUE)	2-1
BRAKE UNIT RATING.....	2-2
MAIN COOLING FAN SUPPLY REQUIREMENTS	2-2
AC LINE CHOKE	2-3
REQUIREMENTS FOR UL COMPLIANCE	2-4
MECHANICAL DETAILS	2-6
ENVIRONMENTAL SPECIFICATION	2-6
Chapter 3 Product Code	3-1
Chapter 4 Troubleshooting	4-1
Chapter 5 Mechanical Requirements for Cabinet Mounting	5-1
Airflow	5-1
Handling of the Drive	5-1
OUTLINE DRAWINGS HG463009G001, 2 & 3	5-3
Chapter 6 Fitting Top Vent and Gasket	6-1
DRAWINGS HG463010G001, 2 & 3.....	6-3
Chapter 7 Fitting Remote Operator Station 6200	7-1
Assembly Procedure	7-1
Cutout Dimensions	7-2

Chapter 8 Inverter Brake Unit Installation Guidelines

OVERVIEW8-1
REQUIRED TOOLS8-1
INSTALLATION PROCEDURE8-1

Chapter 9 Maintenance and Servicing

MAINTENANCE9-1
SERVICING9-1
FAULT FINDING9-1
SPARES LIST9-1
ELECTRO-MECHANICAL PARTS.....9-2
PRINTED CIRCUIT BOARDS9-2
COMPONENT REPLACEMENT.....9-3
PRINTED CIRCUIT BOARD (PCB) REPLACEMENT9-4
FAN REPLACEMENT9-7
PHASE ASSEMBLY REPLACEMENT.....9-9

Appendix A

HL463115C A-1
CO389936D201, 2, 3..... A-2

Appendix B EMC and Filter Installation B-1

EMC FILTERS TO REDUCE LINE CONDUCTED NOISEB-1
SPECIFICATION OF ACHIEVABLE EMC EMISSIONSB-4

Appendix C Declarations C-1

584S/620 (Type 8, 9 & 10) Declaration of Conformity for EMC..... C-1
584S/620 (Type 8, 9 & 10) Manufacturers EMC Declaration C-2
584S/620 (Type 8, 9 & 10) EC Declaration of Conformity for
Electrical Safety C-3
584S/620 (Type 8, 9 & 10) Machinery Directive..... C-4
584S/620 Harmonic Analysis..... C-5

Modification Record

Chapter 2 Technical Specification

GENERAL

The main product manual (584S or 620) details the technical specification of the control circuits, protection circuits, diagnostics and I/O. *Table 2.1*

ELECTRICAL RATINGS - POWER CIRCUITS (620/584S CONSTANT TORQUE) *1 & 2

	TYPE 8			TYPE 9				TYPE 10		
Input Voltage	380V to 460V *4 ±10%, 50/60Hz									
Product Code Block 2	0900	1100	1320	1600	1800	2000	2200	2500	2800	3150
Nominal Motor Power (kW) @ 380V	90	110	132	160	180	200	220	250	280	315
Nominal Motor Power (kW) @ 415/440V	90	110	150	185	200	220	250	280	315	315
Motor Power (Hp) @ 460V (as specified within NEC/NFPA-70)	150	150	200	250	300	300	350	400	450	450
Output Current (A)	180	216	250	316	361	375	420	480	520	550
Input Current (A) *1 & 2	185	220	260	320	365	400	435	490	550	575
Fundamental Input Power Factor	0.95									
Input Bridge I ² t	245 000 A ² s				813 000 A ² s					
Fuse Rating/Circuit Breaker *3 (A)	200	250	300	350	400	450	450	550	600	600
Approx. loss @ 3kHz (kW)	2.4	2.9	3.5	4.3	4.8	5.2	5.4	6.7	7.1	7.5
Switching Frequency	3kHz									
Output Voltage (max)	Input Voltage									
Output Overload	150% for 60 seconds									
Output Frequency	0 to 120Hz									
Fan Inlet temperature Range	0 to 40°C									
IP Rating	IP20 Enclosure IP00 power terminals									
Earth Leakage Current	>>100mA. Product must be permanently earthed									

ELECTRICAL RATINGS - POWER CIRCUIT (584S QUADRATIC TORQUE) *1 & 2

	TYPE 8			TYPE 9				TYPE 10		
Input Voltage	380V to 460V *4 ±10%, 50/60Hz									
Product Code Block 2	0900	1100	1320	1600	1800	2000	2200	2500	2800	3150
Nominal Motor Power (kW) @ 380V	110	132	150	200	220	250	250	300	315	315
Nominal Motor Power (kW) @ 415/440V	110	150	150	225	250	280	280	315	355	355
Motor Power (Hp) @ 460V (as specified within NEC/NFPA-70)	150	200	250	300	350	400	400	450	500	500
Output Current (A)	216	260	302	377	420	480	480	545	595	595
Input Current (A) *1 & 2	220	265	310	400	430	490	490	590	620	620
Fundamental Input Power Factor	0.95									
Input Bridge I ² t	245 000 A ² s				813 000 A ² s					
Fuse Rating/Circuit Breaker *3 (A)	250	300	350	450	450	550	550	650	650	650
Approx. loss @ 3kHz (kW)	2.9	3.5	4.2	5.1	5.6	6.9	6.9	7.6	8.6	8.6
Switching Frequency	3kHz									
Output Voltage (max)	Input Voltage									
Output Overload	110% for 10 seconds									
Output Frequency	0 to 120Hz									
Fan Inlet temperature Range	0 to 40°C									
IP Rating	IP20 Enclosure IP00 power terminals.									
Earth Leakage Current	>>100mA. Product must be permanently earthed									

* Notes (please see over page)

1. **IMPORTANT: 3% line impedance MUST be provided for each module**, and is assumed in the quoted input current values. Failure to do so will severely curtail DC link capacitor lifetime and could result in damage to the input bridge
2. Input current quoted is for 380V supply at the stated motor power. Motor efficiency of 93% is assumed.
3. Short circuit protection Semiconductor Fuses should be installed in the 3-phase supply to the drive module to protect the input bridge. Circuit breakers or HRC fuses will not protect the input bridge.
4. Suitable for earth referenced (TN) and non earth referenced (IT) supplies.

BRAKE UNIT RATING

The type 8, 9 and 10 brake units have the following specification -

Maximum braking power: 150%

Operating voltage: 750 - 820 V dc

Maximum duty cycle: 30%

Maximum on time: 20 Seconds

Table 2.2

Drive size	Max. Brake Current @750Vdc	Minimum Brake Resistance
Size 8 / 0900	220A	3.40 ohms
Size 8 / 1100	264A	2.84 ohms
Size 8 / 1320	300A	2.50 ohms
Size 9 / 1600	360A	2.00 ohms
Size 9 / 1800	440A	1.70 ohms
Size 9 / 2000-2200	450A	1.60 ohms
Size 10 / 2500	525A	1.43 ohms
Size 10 / 2800-3150	675A	1.11 ohms

MAIN COOLING FAN AND SUPPLY REQUIREMENTS

The type 8 and 9 inverters have an integral main cooling fan. The type 10 inverter has a separate main cooling fan which must be fitted to the bottom panel of the enclosure as shown in drawing HG463009G001 (Chapter 5) with the 4 off M6 nuts provided. Refer to drawing HG463151D002 (Chapter 9) for fan wiring details (type 10 only).

The type 8, 9 and 10 each require an external single phase supply and fuse protection (motor start type) for the main cooling fan.

Table 2.3

	TYPE 8	TYPE 9	TYPE 10
Supply Voltage	110 to 130 VAC, 50/60 Hz		
Fuse Rating	3 A	6 A	10 A
Supply Voltage	220 to 240VAC, 50/60Hz		
Fuse Rating	2A	4A	6A
Airflow Requirement	750m ³ /h (425CFM)	1200m ³ /h (700CFM)	1700m ³ /h (1000CFM)

AC LINE CHOKE

The type 8, 9 and 10 inverters require the use of an AC line choke. In the event of a system comprising a number of type 8, 9 and 10 modules connected to a common supply, a separate AC line choke is required in the supply to each module.

The AC line choke impedance required is nominally 3% of the inverter rating for the highest power build of each frame size. Eurotherm Drives can supply the following line chokes:

Table 2.4

Chassis size	Inductance/phase	RMS current	Peak instantaneous current	Eurotherm Drives part no.
TYPE 8	75µH	308A	±1000A	CO389936U201
TYPE 9	50µH	490A	±1600A	CO389936U202
TYPE 10	35µH	620A	±2200A	CO389936U203

The choke should not saturate at the peak instantaneous current level specified. This value accommodates the 150% overload condition.

For complete details refer to the following Eurotherm Drives drawings included in Appendix A:-

HL463115C Rating Specification for HPAC AC Line Choke

CO389936D201/2/3 584S Type 8,9 and 10 Choke Outline Drawing

Where an inverter is individually supplied from a dedicated transformer with the required impedance, the AC line choke is not required. When an EMC filter is used the line choke must go between the filter and inverter.



Failure to provide the correct line impedance will severely reduce the inverters lifetime and could result in catastrophic failure of the inverter.

REQUIREMENTS FOR UL COMPLIANCE

Solid State Motor Overload Protection

General

The Model 584S/620 Type 8, 9 and 10 Series provide Class 10 Motor Overload Protection. The maximum internal overload protection level (current limit) is 150% for 60 seconds for Model 584S/620 Series (Industrial Ratings) and 110% for 10 seconds for Model 584S Series (HVAC Ratings).

Model 584S Series

The Motor Overload Protection provided is programmable. Refer to 584S Series Product Manual HA389756 Chapter 4 under Current Limits for user adjustment information describing “Motor I Limit” (Motor Current Limit) and “Op Current Cal” (Operation Current Calibration) parameters.

Model 620 Series

The Motor Overload Protection provided is programmable. Refer to 620 Series Product Manual HA463584 Chapter 5 describing “Alarms” for user adjustment information.

Note: It is important that the Stall Inhibit parameter is set to “FALSE” in order to provide inherent Solid State Motor Overload Protection. Should the Stall Inhibit parameter be set to “TRUE”, an external motor overload protective device must be provided by the installer.

Motor Base Frequency

The motor Base Frequency rating is 480 Hz maximum.

Field Grounding Terminals

The International Grounding Symbol  (IEC Publication 417, Symbol 5019) is used to designate the field grounding terminals. Refer to Chapter 1 “Terminal Descriptions”.

Field Wiring Terminal Markings

For correct field wiring connections that are to be made to each terminal, refer to Chapter 1 “Terminal Descriptions”.

Field Wiring Temperature Rating

Use 75°C minimum Copper Conductors only.

Terminal Tightening Torque

Power and Control Terminals

For the correct value of tightening torque, refer to Chapter 2 “Mechanical Details”.

Auxiliary (Fan Supply) Terminals

The tightening torque for the auxiliary terminals is 7.0 lbf-in. (0.78 Nm) maximum.

Auxiliary (Fan Supply) Terminals

The auxiliary terminals accept a maximum conductor size of No. 10AWG (5.3mm²).

Solid State Short Circuit Protection

These devices are provided with Solid-State Short-Circuit (output) Protection. Branch circuit fusing requirements must be in accordance with the latest edition of the National Electrical Code NEC/NFPA-70.

Short Circuit Rating

Suitable for use on a circuit capable of delivering not more than 100000 RMS Symmetrical Amperes, 460V maximum.

Fuse Replacement Information

The fuses provided on Switch-Mode Power Supply Printed Wiring Board (see Chapter 9) must be replaced with those manufactured by Bussmann, Type HVR, or equivalent, rated 2A, 1000V dc. Refer to Figure 9.2 in Chapter 9.

The fuses provided on Line Suppression Printed Wiring Board (AH389192) must be replaced with those manufactured by Bussman, Type KTK-10, or equivalent, rated 10A, 600V. Refer to Figure 9.3, Chapter 9.

MECHANICAL DETAILS

Table 2.5

TYPE 8, 9 AND 10 (COMMON)

Mounting Orientation	Vertical
Power Terminations	<p>3-phase supply and output terminals Bus-bars with 2 off M12 holes, 25mm separation. 2 off M12 bolt, nut and washer supplied. Tightening torque 97Nm (71.5lb-ft)</p> <p>Protective Earth terminals 4 off M10 bolts with conical washers - supplied loose Tightening torque 55Nm (40.5lb-ft)</p> <p>DC link terminals Bus-bars with 2 off M12 holes, 35mm separation. Designed to accept semiconductor fuses directly mounted on terminals (eg. Gould Sawmut A100P) 2 off M12 bolt, nut and washer supplied. Tightening torque 97Nm (71.5lb-ft)</p> <p>Dynamic Brake terminal Bus-bars with 2 off M12 holes, 44mm separation. 2 off M12 bolt, nut and washer supplied. Tightening torque 97Nm (71.5lb-ft)</p>
Control Terminations	<p>Removable screw connectors for 0.75mm² wire (18 AWG). Terminals will accept up to 1.5mm² wire (16 AWG). Tightening torque 0.6Nm (0.4lb-ft)</p>

TYPE 8

Weight	100kg (108kg including DB unit)
Dimensions	Refer to drawing HG463009G003 (Chapter 5)

TYPE 9

Weight	125kg (138kg including DB unit)
Dimensions	Refer to drawing HG463009G002 (Chapter 5)

TYPE 10

Weight	160kg (176kg including DB unit)
Dimensions	Refer to drawing HG463009G001 (Chapter 5)

ENVIRONMENTAL SPECIFICATION

Table 2.6

Humidity (max.)	85% relative humidity at 40°C non-condensing
Altitude	Above 1000m derate 1% per 100m,
Atmosphere	Non flammable, non corrosive and dust free
Operating temperature range	0°C to 40°C (Constant torque mode) 0°C to 40°C (Quadratic torque mode)
Storage temperature	Minimum -25°C to maximum +55°C
Transport temperature	Minimum -25°C to maximum +70°C
Climatic Conditions	Class 3k3 as defined by EN50178 (1998)
Pollution Degree	2
Installation / Overvoltage Category	3

Chapter 3 Product Code

All 584S and 620 units are fully identified using an eleven block alphanumeric code. This code details the drive calibration and settings on despatch from the factory. The product code appears as the "Model No." on the rating label at the side of the unit. Details of each block of the product code can be found in the relevant product manual. The product code blocks detailed apply to the type 8, 9 and 10 with the following exceptions:

Table 3.1

Block No.	Variable	Description
2	XXXX	<p>Four numbers specifying the constant torque power rating kW. (For quadratic torque see Electrical Ratings - Power Circuit (584S Quadratic torque) table 2.1). Horsepower ratings below as specified within NEC/NFPA-70.</p> <p>0900= 90kW @ 380V (150Hp @ 460V) 1100=110kW @ 380V (150Hp @ 460V) 1320=132kW @ 380V (200Hp @ 460V) 1600=160kW @ 380V (250Hp @ 460V) 1800=180kW @ 380V (300Hp @ 460V) 2000=200kW @ 380V (300Hp @ 460V) 2200 = 220kW @ 380V (350Hp @ 460V) 2500=250kW @ 380V (400Hp @ 460V) 2800=280kW @ 380V (450Hp @ 460V) 3150 = 315kW @ 380V (450Hp @ 460V)</p>
3	XXX	<p>Three numbers specifying the nominal input voltage rating: 400 380 to 460V ($\pm 10\%$) 50/60Hz</p>
4	XXXX	<p>Four digits specifying the mechanical package including livery and mechanical package style:</p> <p>First two digits Livery 00 Standard Eurotherm Drives livery 01-99 Defined customer liveries</p> <p>Third digit Mechanical packaging style 1 Standard (IP2X), protected panel mounting (terminals::IPOO)</p> <p>Fourth digit Operator Station 0 Standard product (must be 0) - Operator station fitted</p>
10	XXX	<p>Three digits specifying the cooling fan auxiliary supply: 115 115V fan option supplied. 230 230V fan option supplied.</p>

Chapter 4 Troubleshooting

In addition to the diagnostics provided by the opstation, eight fault LEDs situated on the power control board provide an indication of the cause of a fault trip. The fault LEDs are visible when the bottom terminal cover is removed - refer to Figure 1.1. Table 4.1 below indicates the function of the LEDs.

Table 4.1

FAULT	Illuminated LEDs							
M1 phase overcurrent	8							1
M2 phase overcurrent	8						2	
M3 phase overcurrent	8					3		
M1 phase IGBT fault alarm				5				1
M2 phase IGBT fault alarm				5			2	
M3 phase IGBT fault alarm				5		3		
DB unit IGBT fault alarm				5	4			
M1 phase IGBT over-temperature			6					1
M2 phase IGBT over-temperature			6				2	
M3 phase IGBT over-temperature			6			3		
DB unit IGBT over-temperature			6		4			
L1 thermostat over-temperature		7						1
L2 thermostat over-temperature		7					2	
L3 thermostat over-temperature		7				3		
AC supply fail	8							
Output current imbalance			6	5				
CAL board not fitted	8	7	6	5				
Internal supply fail	8	7						
FPGA not programmed	8	7	6	5	4	3	2	1

The suggested course of action in response to the diagnostic LED alarms is summarized in table 4.2:

Table 4.2

FAULT	ACTION
M1 phase overcurrent	Output current greater than trip level. Check output wiring and motor for insulation breakdown or short-circuits either between phases or between phase and earth.
M2 phase overcurrent	
M3 phase overcurrent	
M1 phase IGBT fault alarm	Excessive output current. Maximum IGBT junction temperature exceeded - check main cooling fan.
M2 phase IGBT fault alarm	
M3 phase IGBT fault alarm	
DB unit IGBT fault alarm	Check wiring and verify value of brake resistor.
M1 phase IGBT over-temperature	Maximum IGBT junction temperature exceeded. Check operation of main cooling fan and supply. Check that cooling path is free from obstruction.
M2 phase IGBT over-temperature	
M3 phase IGBT over-temperature	
DB unit IGBT over-temperature	Clean or replace cubicle inlet air filters.
L1 thermostat over-temperature	Maximum input bridge temperature exceeded. Check that motor load is within drive rating. Check value of AC line choke.
L2 thermostat over-temperature	
L3 thermostat over-temperature	
AC supply fail	One or more supply phases missing - check supply wiring.
Output current imbalance	Check wiring to motor and motor itself for earth faults.
CAL board not fitted	Internal fault - consult supplier
Internal supply fail	Internal fault - consult supplier
FPGA not programmed	Internal fault - consult supplier

Chapter 5 Mechanical Requirements for Cabinet Mounting

Airflow

The size 8, 9 and 10 of the 584S and 620 Series utilize very large airflows and have been designed with specific airflow patterns within a cabinet. Generally it is intended that the bulk of the air comes into the cabinet at the top, flows down (some going through the drive to maintain internal temperatures), into the main cooling fan, through the drive, the brake/exhaust duct (supplied), and finally out the top of the cabinet through vent assembly (supplied). This flow pattern insures that the top of the cabinet is effectively evacuated and the inside of the drive is cooled by fresh air. The brake/exhaust duct allows for field installation of a braking module and it gives clearance for inlet air to come from the front of the cabinet into the top of the drive and down; it is strongly recommended that this is fitted with the drive whether a brake is fitted or not. It is also important that the top vent be properly fitted to assure that the exhaust air is not recirculated (see figure 5.1). See HG463009G001, 2 and 3 for typical cubicle layout information.

It is recommended that these drives be separated from other equipment in a large multifunction cabinet so that the airflow is better controlled. i.e. air heated by other items should not affect the inlet temperature to the drive's main fan.

Figure 5.1

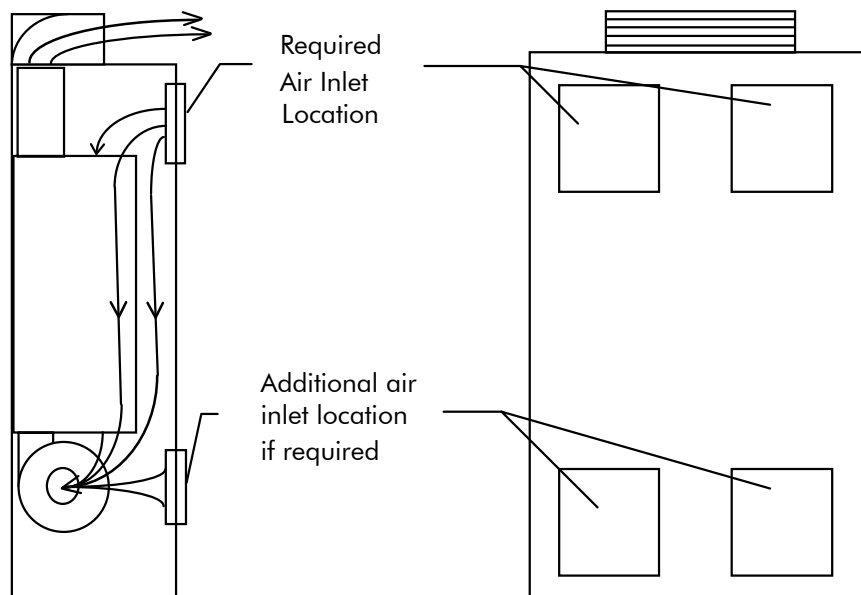

Care should be taken in placing the cabinet so that there is sufficient space in front of the cabinet to keep the exhaust air and inlet air separated. If there is not sufficient space, redirection of the exhaust air is required. These drives dissipate substantial heat (see Chapter 2, Table 2.1 for Approx. loss) and therefore sufficient volume for exhaust venting is required to keep the drive from raising the operating temperature beyond that specified in the Environmental Specification.

Handling of the Drive

The drives are supplied with 4 lifting eye bolts fitted to the 4 PE/grounding locations on the sides of the drive for handling via hoist. The size 8 and 9 may also be set on end for installation by forklift. The size 10 may be placed on forklift blades with care to avoid the fan mounting studs and fan power terminals on the bottom (with the fan removed - the fan is shipped separately from the drive).

Under no circumstances should the drive be lifted via the power terminals.

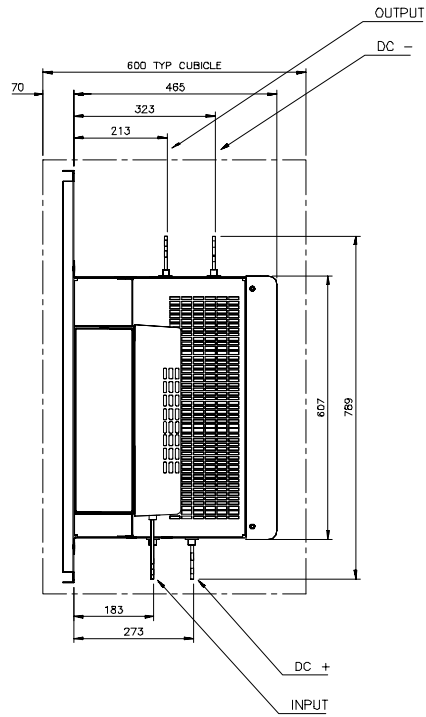

NOTES:

1. REFER TO HG 389313 G 001 & HG 463010 G 001 FOR FURTHER DETAILS.
2. AREAS INDICATED  TO BE FREE FROM ANY OBSTRUCTION TO ALLOW AIRFLOW THROUGH PRODUCT.

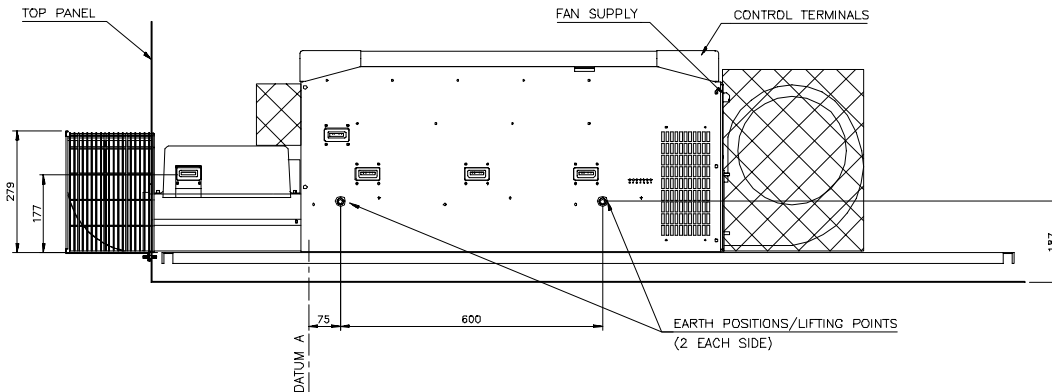
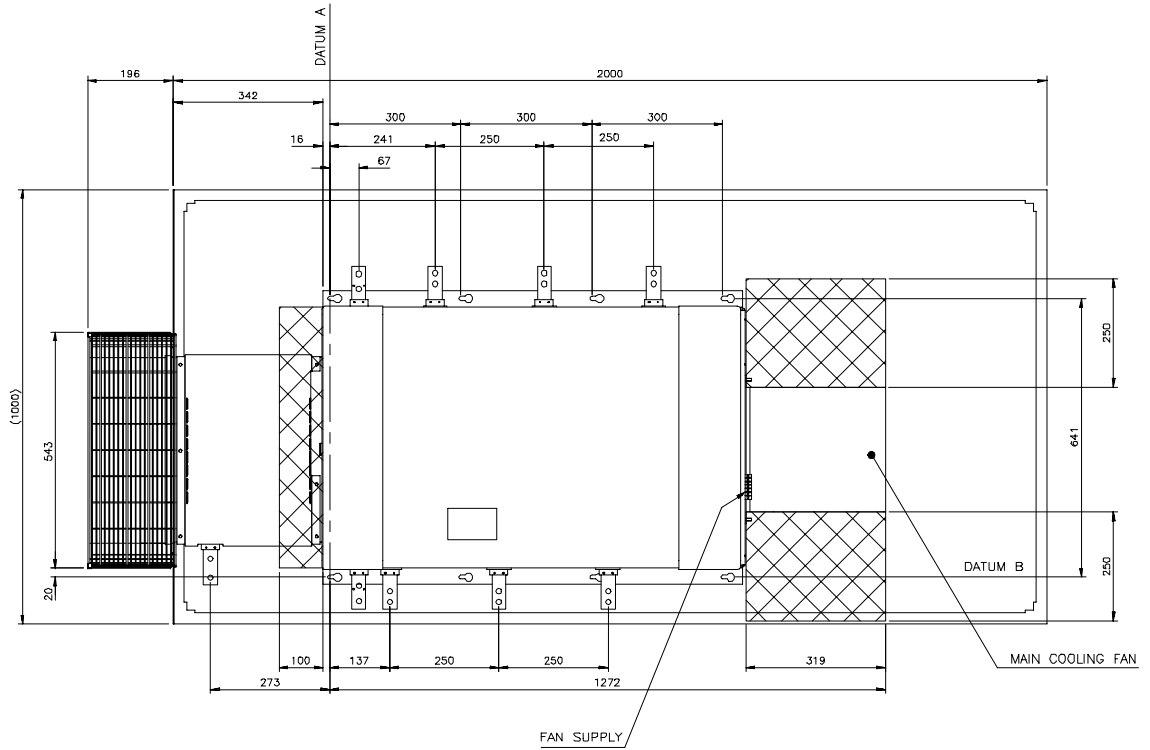

Size 10 Typical Cubicle Installation Outline Drawing (HG 463009 G 001)

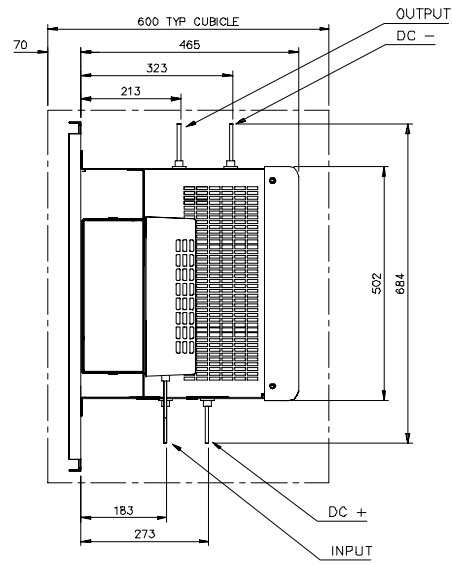

VIEW ON TOP OF UNIT WITH
FAN VENT ASSEMBLY REMOVED.

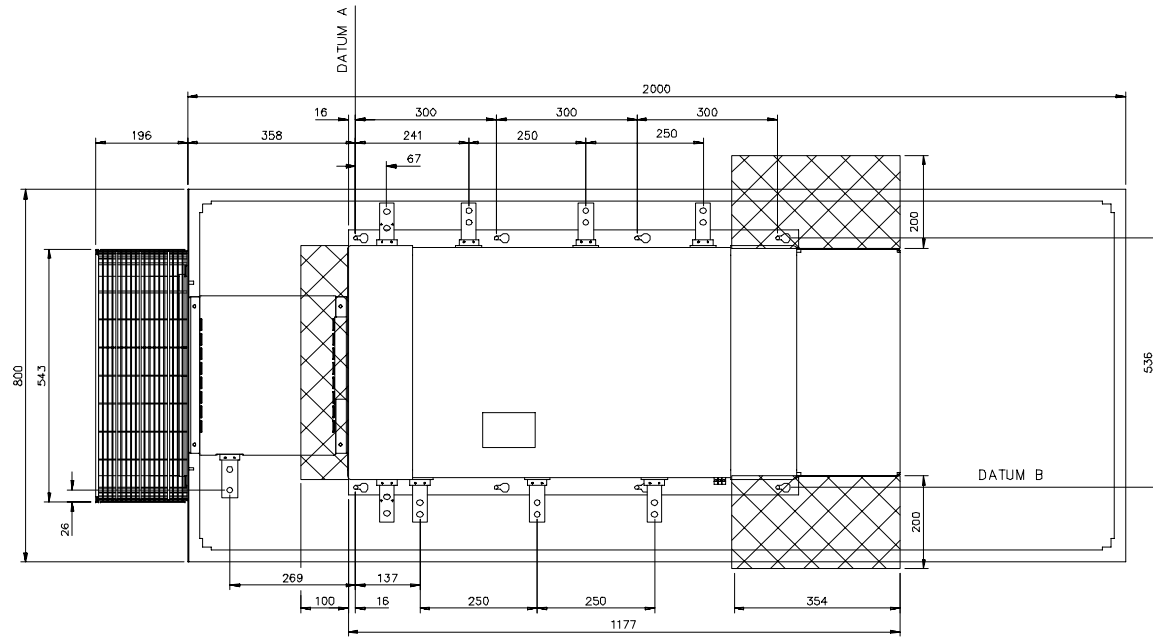

NOTES:

1. REFER TO HG 389313 G 002 & HG 463010 G 002 FOR FURTHER DETAILS.
2. AREAS INDICATED TO BE FREE FROM ANY OBSTRUCTION TO ALLOW AIRFLOW THROUGH PRODUCT.

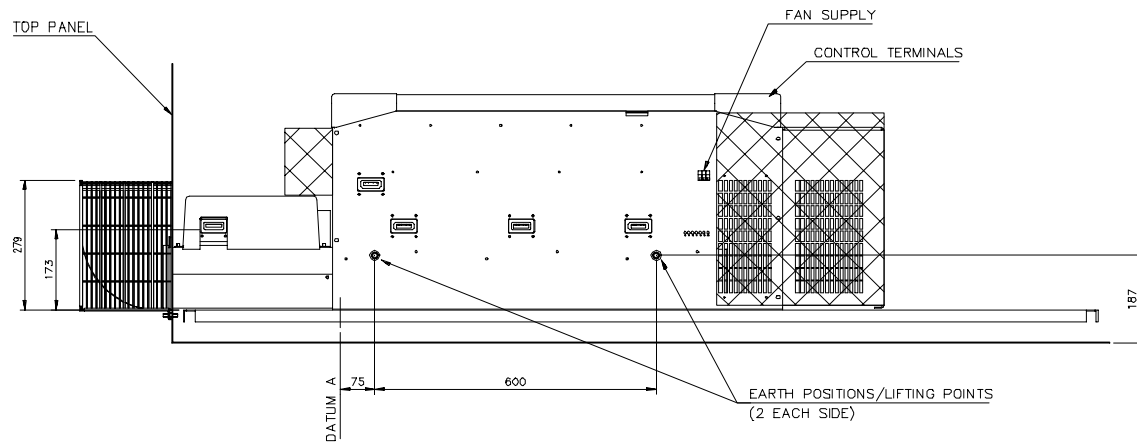

Size 9 Typical Cubicle Installation Outline Drawing (HG 463009 G 002)

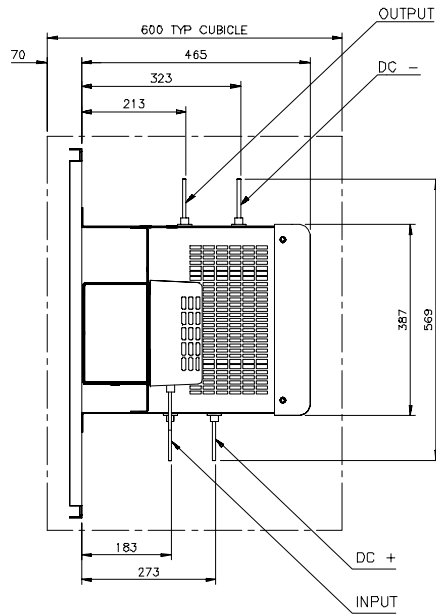

VIEW ON TOP OF UNIT WITH
FAN VENT ASSEMBLY REMOVED.

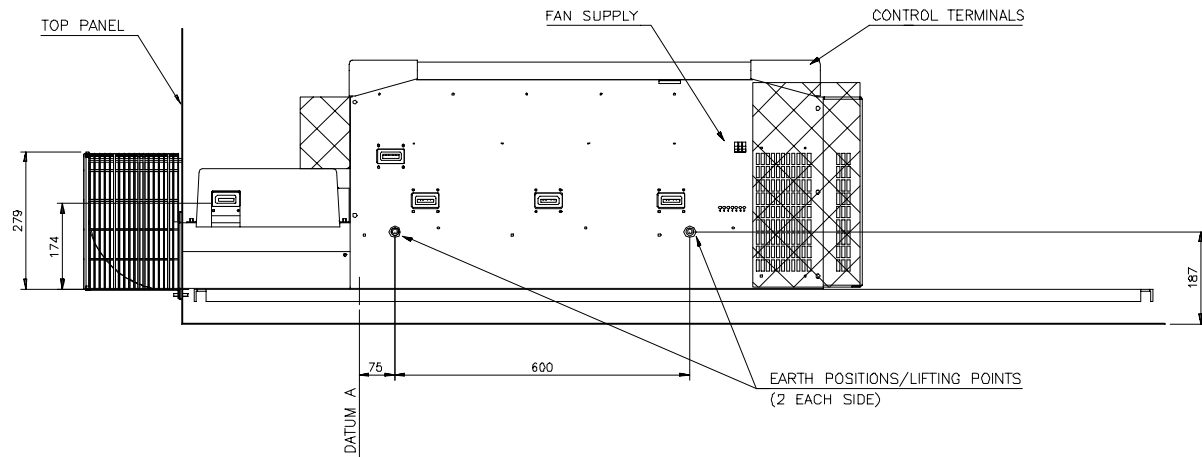
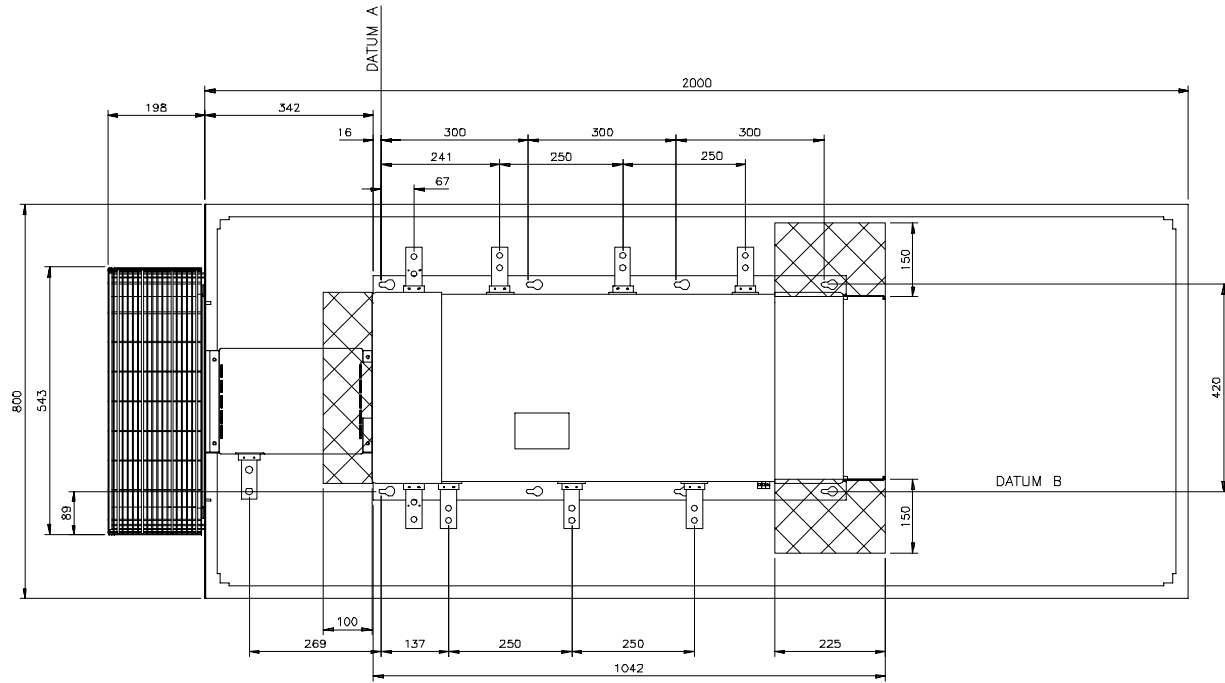

NOTES:

1. REFER TO HG 389313 G 003 & HG 463010 G 003 FOR FURTHER DETAILS.
2. AREAS INDICATED TO BE FREE FROM ANY OBSTRUCTION TO ALLOW AIRFLOW THROUGH PRODUCT.

Size 8 Typical Cubicle Installation Outline Drawing (HG 463009 G 003)

Chapter 6 Fitting Top Vent and Gasket

Warning! This unit must be operated with either a brake unit or blanking plate fitted to the supplied outlet duct. The top vent is then mounted on to the outlet duct. It is very important that the gasket for the vent is correctly fitted to the exhaust/brake outlet duct. Otherwise, hot exhaust air will flow back into the cabinet and overheat the drive. The brake/exhaust outlet duct should protrude from the top of the cabinet by 5-10mm to ensure engagement with the gasket. See installation drawings HG463010 G 001, 002, and 003.

This assembly provides IP-22 protection for the drive when fitted properly. The main function is to seal the path of return air to the enclosure as well as protect against falling contaminants. The same assembly is used for the type 8, 9, and 10. The different sizes are accommodated by removal of the gasket inserts.

Supplied parts:

Qty. Description

1	Vent top
1	Top Vent Baffle
1	Mounting Flange
1	Gasket
4	M6 support studs
2	M6 x 195 hex studs
1	Grille
8	M6x25 panhead slotted screws
8	M6 flat washers
20	M6 hex captive nuts

Tools Required:

- M10 wrench, quantity 2
- #3 Phillips or posidrive screwdriver
- 10mm (3/8") flat blade screwdriver

Assembly Procedure (see Figure 5.2)

On cabinets with removable panels the following procedure should be performed off the cabinet. For non-removable cabinets this procedure should be performed prior to mounting the drive.

Note: If the drive is not removed, then it must be protected from any cutting chips.

1. Cut top of cabinet as per drawing HG463010 G 001, 002, or 003.
2. Install (4) M/M support studs in rearmost row of holes in pattern
3. Install (2) F/F M6 x 195 support studs in forward most holes with (2) M6 x 10 posidrive screws

The following should be done with the drive and exhaust duct fitted to ensure good fit of gasket to duct.

4. Fit the gasket over the 4 support studs and exhaust duct.
5. Fit the mounting flange over the gasket and attach via (8) M6 x 25 screws, (16) M6 washers, and (8) M6 nuts.
6. Fit the top vent baffle over the support studs.
7. Fit grommet strip to bottom edge of grill and position.
8. Fit vent top over the 4 support studs and grill.
9. Fix vent top via (2) M6 x 10 screws (using a 10 mm wrench on the support studs through the grill is helpful in aligning the stud to the hole in the top) and (4) M6 nuts and washers.

Figure 6.1

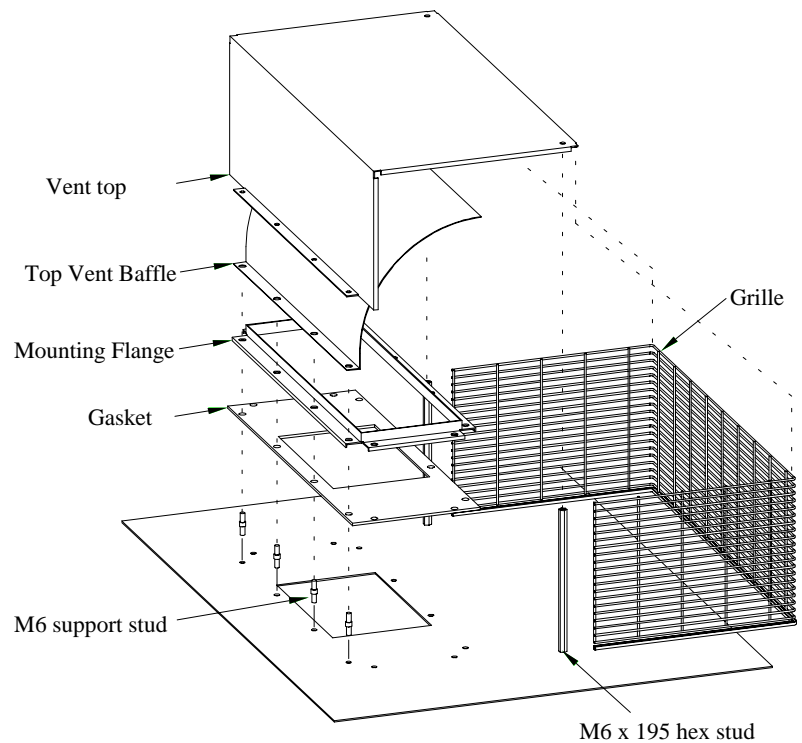

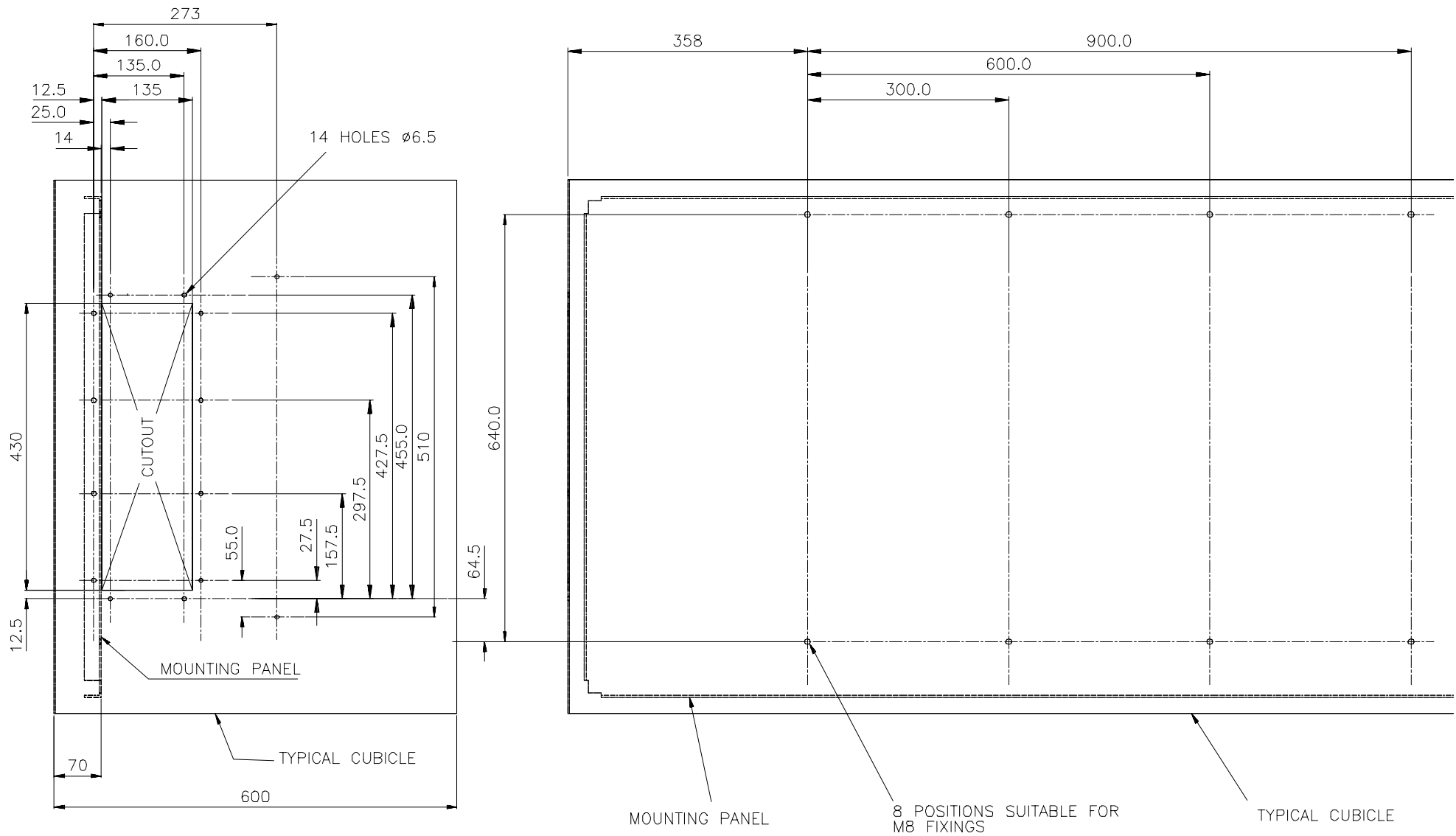

Size 10 Typical Cubicle Machining (HG463010 G 001)

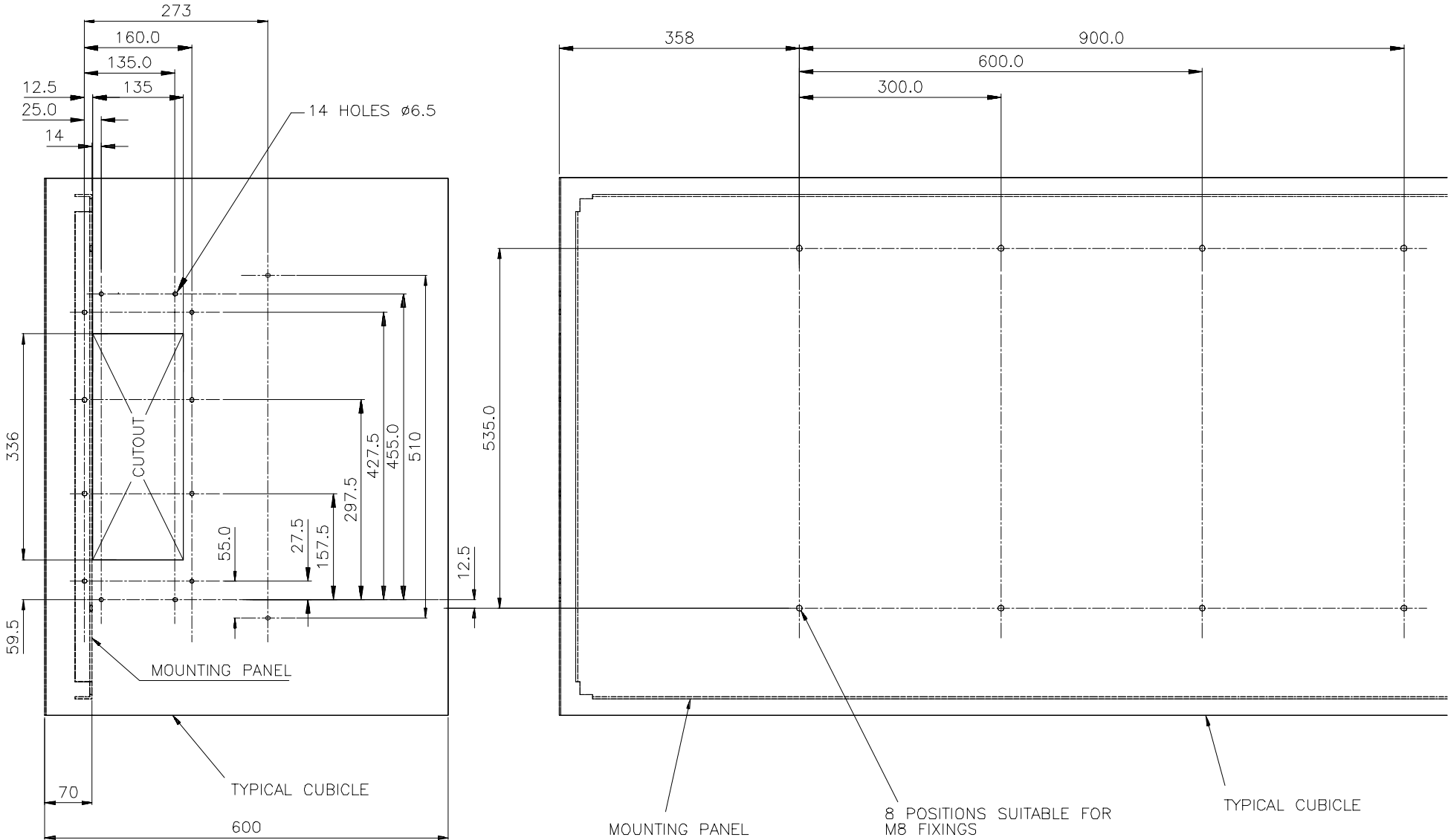

Size 9 Typical Cubicle Machining (HG 463010 G 002)

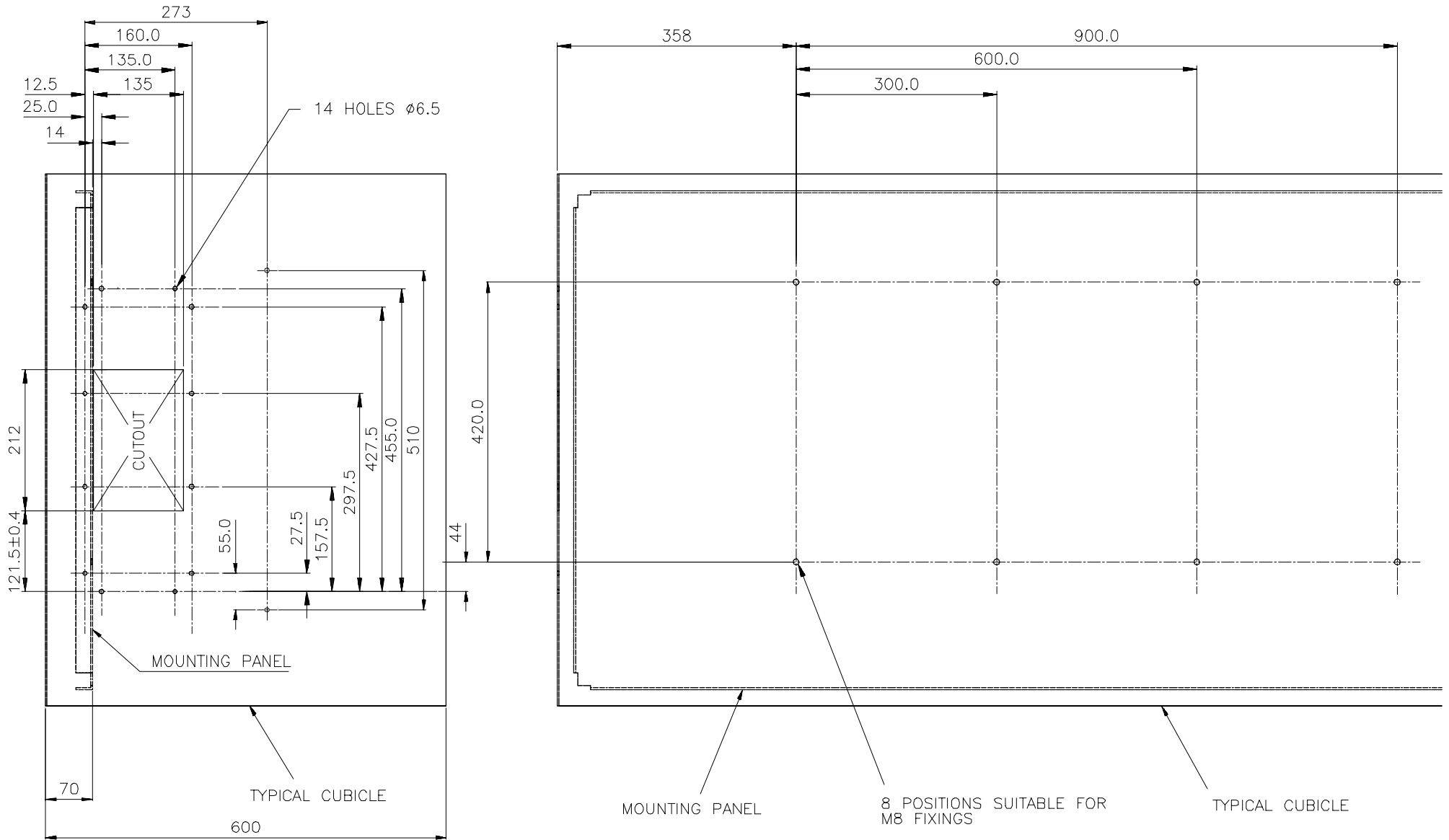

Size 8 Typical Cubicle Machining (HG 463010 G 003)

Chapter 7 Fitting Remote Operator Station 6200

The type 8, 9, and 10 584S and 620 series drives are designed to allow use of a remote mounted operator station. This is available as a kit Model Number 6200 and may be fitted to the outside of a cabinet. It replaces the drive mounted Operator Station. The two cannot be operated simultaneously. The Remote Operator Station is connected to the power control board (see Figure 7.1) via a 30 way ribbon cable 2 meters long.

Figure 7.1

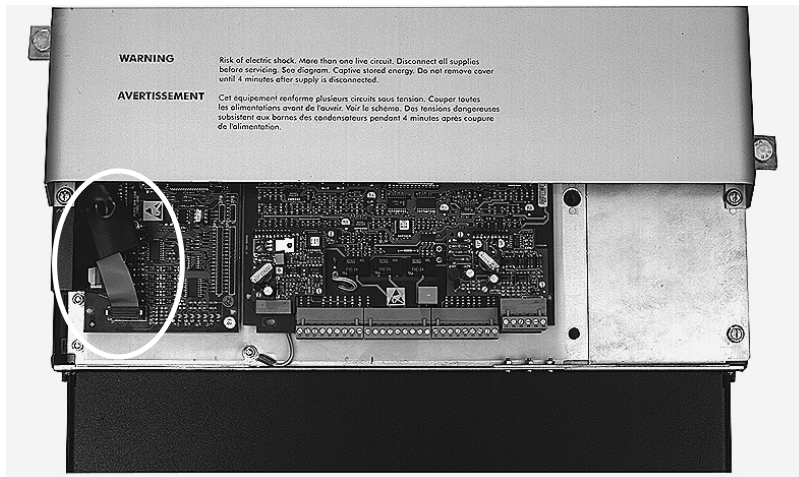

WARNING

The 30 way ribbon cable insulation is only rated for 300 volts and must be treated appropriately.

The 30 way ribbon cable cannot be lengthened.

Upon removal of the drive mounted Operator Station cable, the protective sleeving must be brought down to cover the loose cable.

Supplied parts:

Qty.	Part Number	Description
1	BT463265	GASKET REMOTE OP-STATION
1	CM463268U001	30 WAY CABLE ASSY. FOR REMOTE OP STATION
1	LA463221U001	OP STATION STANDARD
1	BD388329U001	OP STATION RETAINING MOULDING
4	FB084K12	SCREW No. 6 x 12mm

Tools Required:

#2 Phillips or posidrive screwdriver.

Assembly Procedure

1. Locate desired position of operator station.
2. Drill 4 mounting holes (see figure 7.2).
3. Cut out cable aperture (see figure 7.2).
4. Peel backing off the gasket and attach to panel.
5. Insert operator station to bezel and screw to panel.
6. Remove drive mounted Operator Station cable from power control board (see figure 7.1) and slide protective sleeve down over cable end to keep it from causing short circuits.
7. Connect supplied cable (note the cable is not symmetric and the end marked "Control Board" must be attached to the drive board).
8. Route cable from drive to operator station and attach, ensuring that adequate protection from live parts and abrasion is achieved.

Chapter 8 Inverter Brake Unit Installation Guidelines

OVERVIEW

Type 8, 9 and 10 brake units are optional. It is however, possible to retro-fit a brake unit (**ONLY if drive was shipped ON OR AFTER 9-12-96**) should the need arise. There are three brake units, one for each drive frame size. The brake unit is shipped with an exhaust brake duct (see figure 8.1). The original exhaust duct supplied with the drive or the exhaust duct supplied with the brake unit may be used in the final installation.

The brake unit consists of the following parts (see figure 8.1):

- Exhaust Duct.
- Heatsink & IGBT assembly.
- Control cable.
- Brake connection plates - 1 set for type 8/9 and 2 sets for type 10.
- Snubber capacitors and screws.
- Heatsink fixings.
- Brake unit cover and retaining nuts.
- Earth bonding bracket.

The brake unit is shipped in a pre-assembled state (except for the connection plate(s)). It is recommended that this assembly is carefully studied prior to installation within the cubicle. It is also recommended that the brake unit heatsink/IGBT assembly is removed from the exhaust duct before installing the unit within the cubicle.

REQUIRED TOOLS

- M10 spanner
- #3 posidrive or phillips torque screwdriver
- #2 posidrive or phillips torque screwdriver

INSTALLATION PROCEDURE

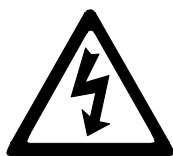

THE FOLLOWING PROCEDURE SHALL BE CAREFULLY ADHERED TO FOR SAFETY REASONS.

ALL ELECTRICAL SUPPLIES SHALL BE DISCONNECTED BEFORE WORKING ON THE INVERTER - ALLOW 15 MINUTES FOR THE DRIVE DC LINK CAPACITORS TO FULLY DISCHARGE.

WARNING! CARE SHOULD BE EXERCISED TO NOT DROP ANY SCREWS, NUTS OR EXTRANEIOUS PARTS INTO THE DRIVE.

See figures 8.2 and 8.3 for typical brake unit installation.

1. Remove brake unit cover.
2. Remove the snubber capacitors from the brake unit IGBT module.
3. Remove earth bonding bracket from heatsink.
4. Loosen heatsink clamps and rotate out of way.
5. Remove heatsink/IGBT assembly and carefully place on a clear flat surface - take care not to damage the heatsink fins.
6. If retro-fitting brake unit to an existing exhaust duct then: Remove exhaust duct aperture cover and screws. Transfer heatsink clamps, washer, bolts and springs from shipping brake duct to existing drive duct.
7. Remove drive top front cover (plastic) via 2 off $\frac{1}{4}$ turn fasteners at top of drive.

8. Remove drive top cover which is attached via 4 off M5 screws on the side and 2 off M5 screws on the top. Care should be taken to keep the cover from falling into the drive and damaging the internal components.
9. Install brake unit IGBT/heatsink assembly within exhaust duct and tighten clamps.
10. Connect brake unit control cable to the 14 way bulkhead connector at the top of the drive.
11. Fit the brake connecting plate(s) to the phase joining tabs of the drive top phase (M3/U) with M6 screws provided (finger tight only). This is achieved by placing the end of the connecting plate with threaded tabs under the phase joining tabs (see figure 8.3).
12. Fit the snubber capacitors (qty 2 size 8, qty 3 size 9, qty 4 size 10) over the brake joining plate(s) to the IGBT using M6 screws (finger tight only) - see figure 8.3.
13. Tighten all M6 screws on the brake connecting plate to 5 Nm (3.7 ft-lb).
14. Fit earth bonding bracket to heatsink and duct connection/earthing screws (M5) to exhaust duct. Tighten to 4 Nm (3 ft-lb). **NOTE - This connection must not be omitted as it is required for safety reasons.**
15. Replace drive top cover, **exercise care to not damage brake connection plates with the top cover as this will compromise the electrical insulation.** Tighten 4 off M5 screws on side of drive and 2 off M5 screws on top of cover to 2.5 Nm (1.84 ft-lb).
16. Replace drive front top cover with 2 off ¼ turn fasteners.
17. Fit brake unit cover with M6 captive washer nuts.

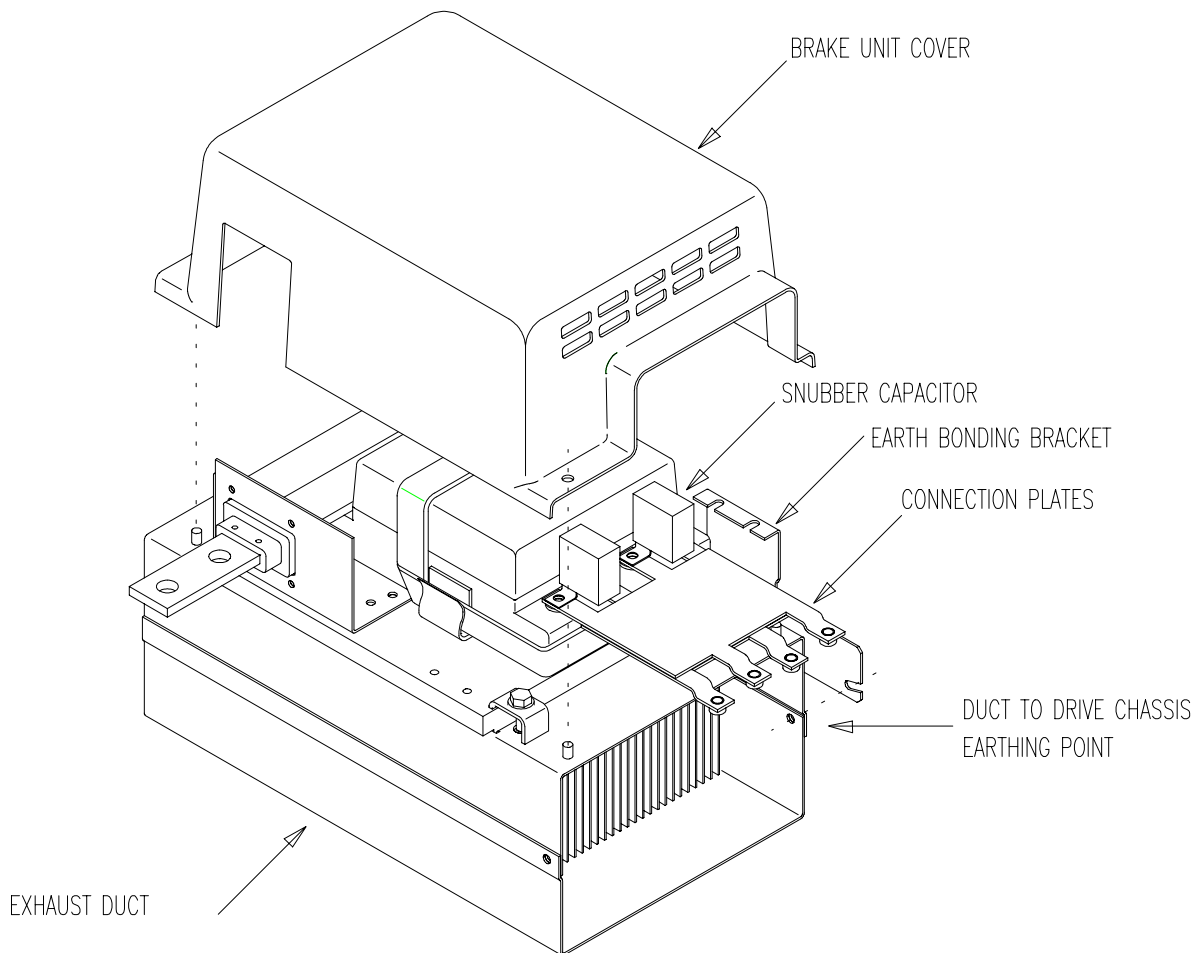

Figure 8.1

Figure 8-2 View without Brake Connecting Plate(s) showing the Control Cable connection between the Brake Unit and the Inverter

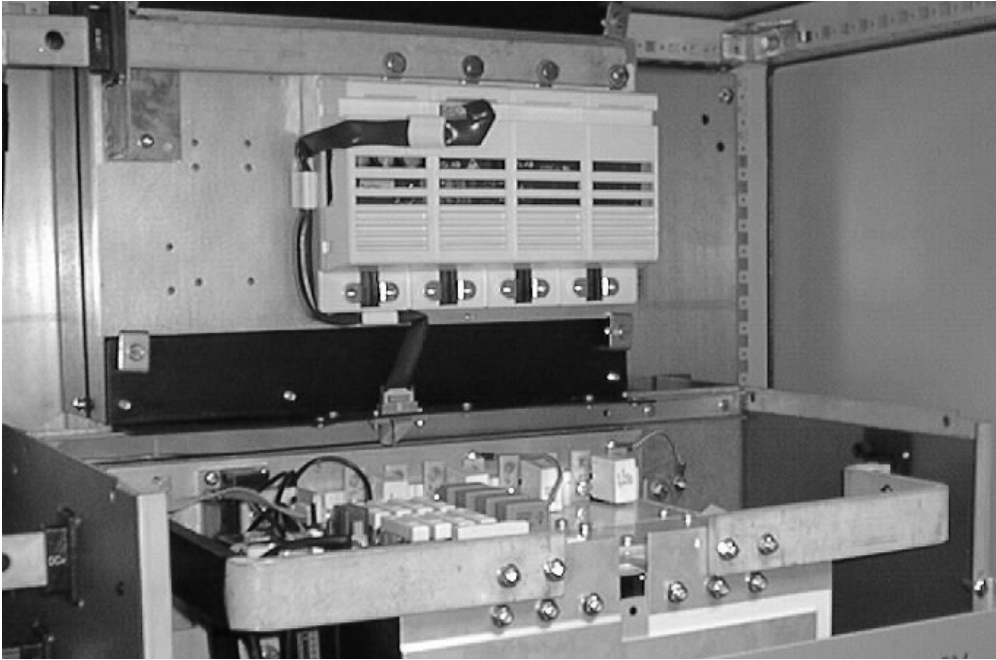
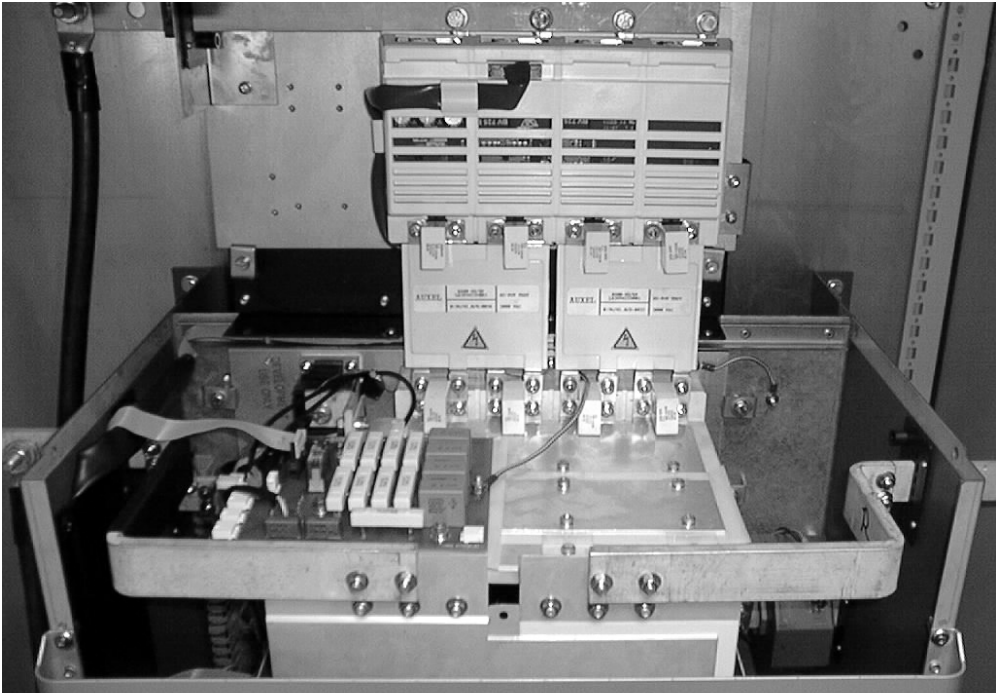

Figure 8-3 Top View of Exhaust Duct/Brake Unit/Inverter Assembly showing the Brake Connecting Plate(s) and Snubber Capacitors fitted



Chapter 9 Maintenance and Servicing

MAINTENANCE

Refer to main 584S or 620 product manual for preventative maintenance guidelines.

SERVICING

The 584S/620 type 8, 9 and 10 range of inverters have been designed to be serviceable units. In the unlikely event of component failure, it is possible to replace the faulty item without having to replace the complete drive unit.

Replacement of components should only be carried out by electrically competent personnel with the knowledge/expertise required to perform the relevant operation.

i.e. in order to replace component parts, drive disassembly, rebuild and re-testing is required.

FAULT FINDING

Troubleshooting - refer to chapter 4 of this manual for guidance. If it is not possible to resolve the problem from the guidelines given in chapter 4 then contact Eurotherm Drives for assistance.

Refer to main 584S or 620 product manual for contact point.

SPARES LIST

Eurotherm Drives are able to provide guidance regarding the necessary component part to be replaced. The serviceable component parts are listed in Table 9.1.

ELECTRO-MECHANICAL PARTS

The selection of the following items are product/kW rating dependant.

Inverter	Main Cooling Fan		Motor Start Capacitor for Main Cooling fan		Internal Extractor Fan (2 required) (Type 10 only)	
	Fan voltage		Fan voltage		Fan voltage	
	115V	230V	115V	230V	115V	230V
Type 8	DL389775	DL464085	CY389841	CY464087	-	-
Type 9	DL389776	DL464086	CY389842	CY464088	-	-
Type 10	DL389776	DL464086	CY389842	CY464088	DL049612	DL049612*

* 2 fans wired in series for 230V rating

Inverter	Phase Assembly (Drive build standard <200)	Brake Unit Assembly (Drive build standard <200)	Phase Assembly (Drive Build standard >200)	Brake Unit Assembly (Drive Build standard >200)
	Type 8 90kW 110kW/132kW	LA464082U001 LA464082U001	LA464083U001 LA464083U001	LA464082U100 LA464082U101
Type 9	LA464082U002	LA464083U002	LA464082U102	LA464083U102
Type 10	LA464082U003	LA464083U003	LA464082U103	LA464083U103

PRINTED CIRCUIT BOARDS

The printed circuit boards listed below are common within the 584S/620 type 8, 9 and 10 range of inverters.

Description	Part Number (Drive build standard <200)	Part Number (Drive build standard >200)
	Switch Mode Power supply PCB	AH389166U101
Power Control PCB	AH389167U001	AH464471U001
Line Suppression PCB	AH389192U001	AH389192U001

Table 9.1

COMPONENT REPLACEMENT

Introduction

Having identified the faulty component part and taken delivery of replacement part(s) the following replacement procedure should be carefully adhered to.

WARNING : FAILURE TO FOLLOW PROCEDURE MAY RESULT IN DAMAGE TO THE INVERTER AND POSSIBLE ELECTRICAL SHOCK HAZARD! PERSONNEL PERFORMING COMPONENT REPLACEMENT PROCEDURES MUST BE ELECTRICALLY COMPETENT AND POSSESS THE KNOWLEDGE /EXPERTISE REQUIRED TO PERFORM THE RELEVANT OPERATION.

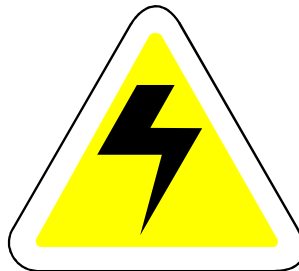

WARNINGS!

BEFORE PERFORMING MAINTENANCE ON THIS UNIT, ENSURE ISOLATION OF THE MAIN SUPPLY TO TERMINALS L1, L2 AND L3.

WAIT FOR AT LEAST 5 MINUTES FOR THE DC LINK TERMINALS (DC+ AND DC-) TO DISCHARGE TO SAFE VOLTAGE LEVELS (<50V), FAILURE TO DO SO CONSTITUTES AN ELECTRICAL SHOCK HAZARD.



Static Sensitive

This equipment contains electrostatic discharge (ESD) sensitive parts. Observe static control precautions when handling, installing and servicing this product.

PRINTED CIRCUIT BOARD (PCB) REPLACEMENT

Observe all electrical warnings and static handling precautions at the front of this section - 'Component Replacement'

Procedure

Power Control PCB, CALIBRATION card and Control PCB (584S/620) Replacement.

1. Remove drive top and bottom terminal cover (plastic) via 2 off $\frac{1}{4}$ turn fasteners at top and bottom of drive (see figure 1.1).
2. Disconnect 30-way op-station ribbon cable from power control PCB CON 10 (see figure 9.1).
3. Remove drive front cover (metal) which is attached via 4 off $\frac{1}{4}$ turn fasteners (take care not to damage PCBs beneath cover).
4. It is now possible to view the power control PCB, control PCB and cal card as shown in figure 9.1.

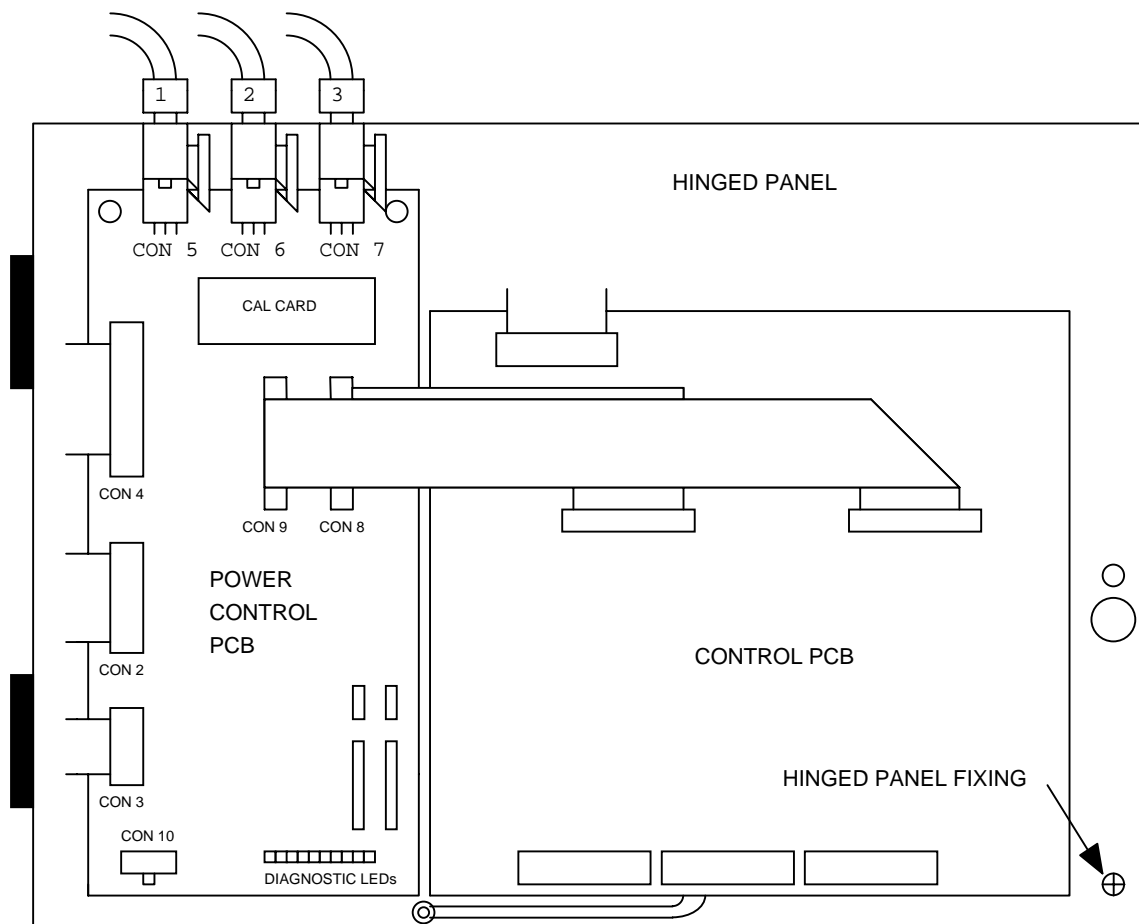

Figure 9.1

5. Take note of PCB connectivity and carefully remove and replace PCB, ensuring that PCB is re-connected correctly.
6. Replace drive front cover (metal) which is attached via 4 off $\frac{1}{4}$ turn fasteners (take care not to damage PCBs beneath cover).
7. Re-connect 30-way op-station ribbon cable to power control PCB CON 10 (see figure 9.1).
8. Re-fit drive top and bottom terminal cover (plastic) via 2 off $\frac{1}{4}$ turn fasteners at top and bottom of drive.

SMPS PCB Replacement

1. Follow steps 1 to 3 of procedure 'Power Control PCB, CAL card and control PCB replacement'. Release hinged panel fixing - 1 off ¼ turn fastener as shown in figure 9.1.
2. The SMPS PCB may now be viewed on reverse side of hinged panel as shown in figure 9.2.

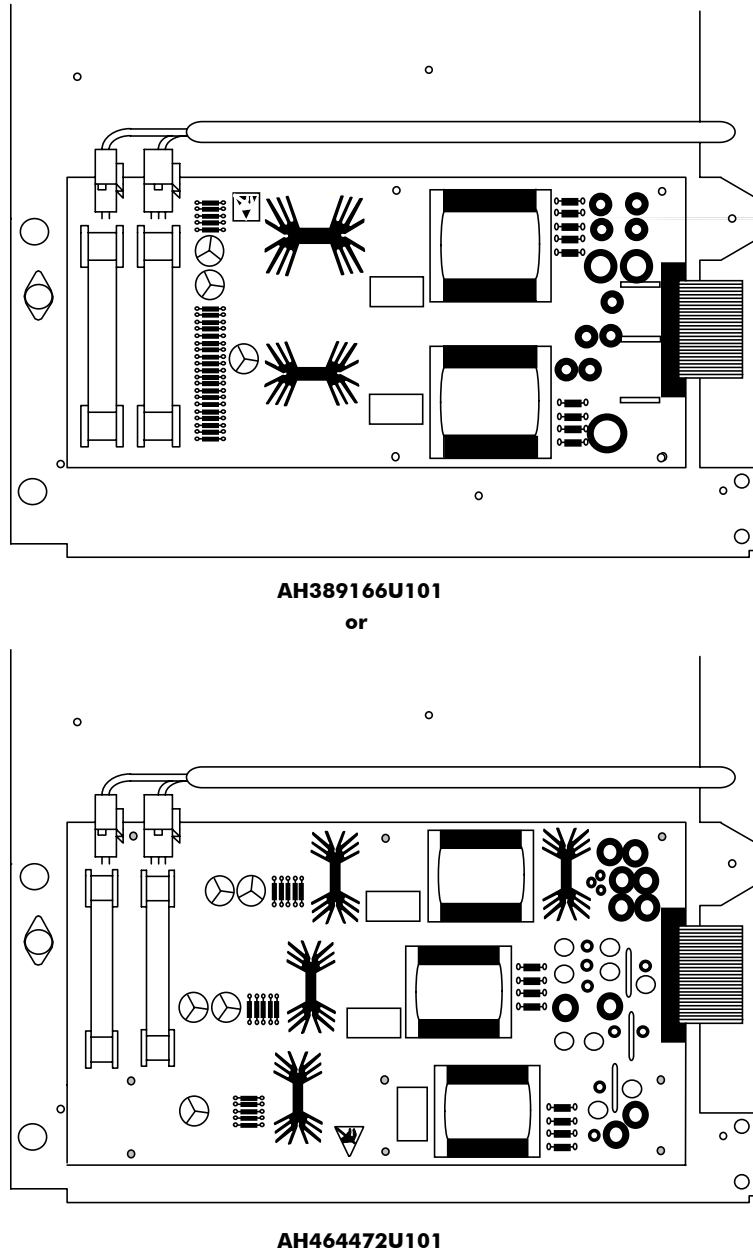

Figure 9.2 SMPS PCB's

3. Take note of PCB connectivity and carefully remove and replace PCB, ensuring that PCB is re-connected correctly.
4. Re-fit hinged panel and ¼ turn fastener as shown in figure 9.1.
5. Replace drive front cover (metal) which is attached via 4 off ¼ turn fasteners (take care not to damage PCBs beneath cover).
6. Re-connect 30-way op-station ribbon cable to power control PCB CON 10 (see figure 9.1).
7. Re-fit drive top and bottom terminal cover (plastic) via 2 off ¼ turn fasteners at top and bottom of drive.

Line Suppression AH389192 PCB Replacement

1. Remove drive top and bottom terminal cover (plastic) via 2 off $\frac{1}{4}$ turn fasteners at top and bottom of drive. (see figure 1.1).
2. Disconnect 30-way op-station ribbon cable from power control PCB CON 10 (see figure 9.1).
3. Remove drive front cover (metal) which is attached via 4 off $\frac{1}{4}$ turn fasteners (take care not to damage PCBs beneath cover).
4. Release hinged panel fixing - 1 off $\frac{1}{4}$ turn fastener as shown in figure 9.1.
5. The line suppression PCB is located inside drive enclosure beneath hinged panel and can be visually identified as shown in figure 9.3.

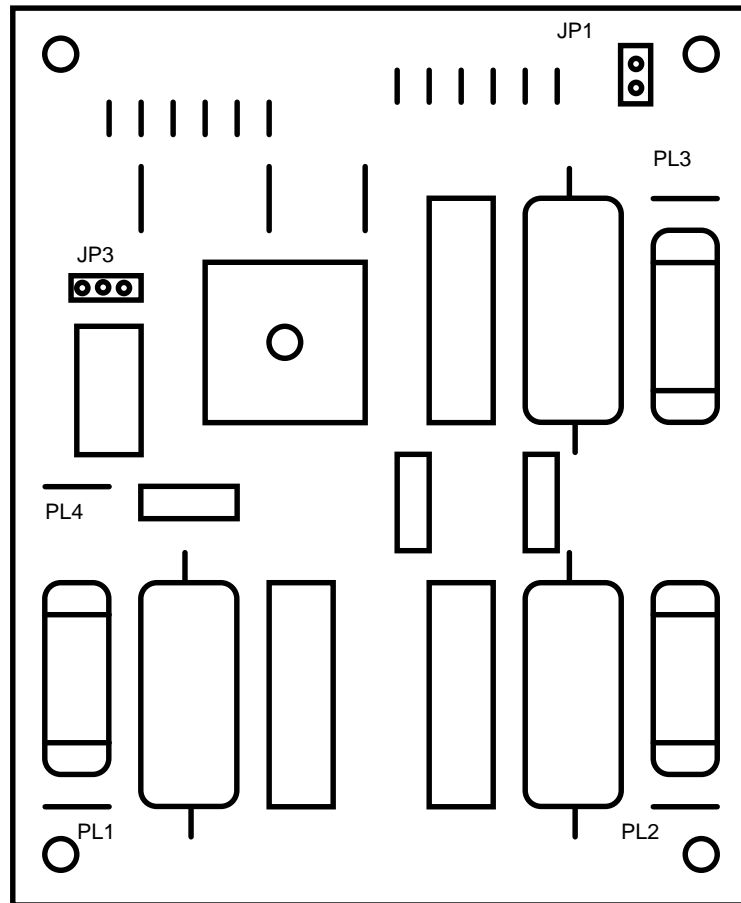

Figure 9.3 - Line suppression PCB

6. Take note of PCB connectivity and carefully remove and replace PCB, ensuring that PCB is re-connected correctly.
7. Re-fit hinged panel and $\frac{1}{4}$ turn fastener as shown in figure 9.1.
8. Replace drive front cover (metal) which is attached via 4 off $\frac{1}{4}$ turn fasteners (take care not to damage PCBs beneath cover).
9. Re-connect 30-way op-station ribbon cable to power control PCB CON 10 (see figure 9.1).
10. Re-fit drive top and bottom terminal cover (plastic) via 2 off $\frac{1}{4}$ turn fasteners at top and bottom of drive.

FAN REPLACEMENT

Observe all electrical warnings and static handling precautions at the front of this section - 'Component Replacement'.

It is possible to replace the drive main cooling fan should the need arise. Having replaced the main cooling fan, ensure that the wiring loom routing/fixing is preserved. *This is an electrical safety requirement.*

Procedure

Type 8 & 9 Inverter Main Cooling Fan and Fan Start Capacitor Replacement

1. Remove drive top and bottom terminal cover (plastic) via 2 off $\frac{1}{4}$ turn fasteners at top and bottom of drive.
2. Disconnect 30-way op-station ribbon cable from power control PCB CON 10 (see figure 9.1).
3. Remove drive front cover (metal) which is attached via 4 off $\frac{1}{4}$ turn fasteners (take care not to damage PCBs beneath cover).
4. Remove Main Fan housing (see figure 1.1).
5. Release hinged panel fixing - 1 off $\frac{1}{4}$ turn fastener as shown in figure 9.1.
6. Take note of fan and fan start capacitor wiring. Disconnect fan and fan start capacitor wiring.
7. Remove fan mounting nuts. Remove fan start capacitor mounting nuts(s). Remove fan and fan start capacitor taking care not to damage other components within drive.
8. Replace fan and fan start capacitor taking care not to damage other components within drive.
9. Re-connect fan wiring loom and ensure that electrical safety isolation is preserved. (refer to wiring diagram HJ463151D001 at the end of this section.)
10. Re-fit fan housing (see figure 1.1).
11. Re-fit drive front cover (metal) via 4 off $\frac{1}{4}$ turn fasteners (take care not to damage PCBs beneath cover).
12. Re-connect 30-way op-station ribbon cable to power control PCB CON 10 (see figure 9.1).
13. Re-fit drive top and bottom terminal cover (plastic) via 2 off $\frac{1}{4}$ turn fasteners at top and bottom of drive.

Type 10 Inverter Main Cooling Fan, Internal Extractor Fan and Main Fan Start Capacitor Replacement

In addition to the main cooling fan, the type 10 inverter also has two internal 120 mm square fans. The main cooling fan, internal cooling fans and main cooling fan start capacitor are mounted on the bottom panel of the drive (See drawing HG 463009G001 - section 5-2 of this manual). Having replaced the fan, ensure that the fan wiring loom routing/fixing is preserved. Refer to wiring diagram HJ463151D002 at the end of this section. *This is an electrical safety requirement.*

Replacement of Fan Start Capacitor

1. Disconnect fan start capacitor wiring (two faston connectors at top of capacitor).
2. Remove fan start capacitor mounting nuts(s).
3. Replace and reconnect start capacitor, taking care not to damage other components within drive.

Replacement of Main Cooling Fan Only

1. Disconnect fan supply wire loom at terminal block on bottom panel of drive. Note the colour coding of the connections to the terminal block
2. Remove fan mounting nuts. Remove fan and fan start capacitor taking care not to damage other components within drive.
3. Re-connect fan wiring loom and ensure that electrical safety isolation is preserved.
4. Refit the lower panel assembly to the drive.

Replacement of Internal 120mm Square Cooling Fans

1. While supporting the fan, remove the 6 M6 screws on the very bottom of the drive.
2. Lower the fan and panel assembly out of the drive.
3. Remove the lower panel assembly.

4. Disconnect supply cable at faulty fan.
5. Replace fan.
6. Reconnect supply cable.
7. Re-fit lower panel assembly.

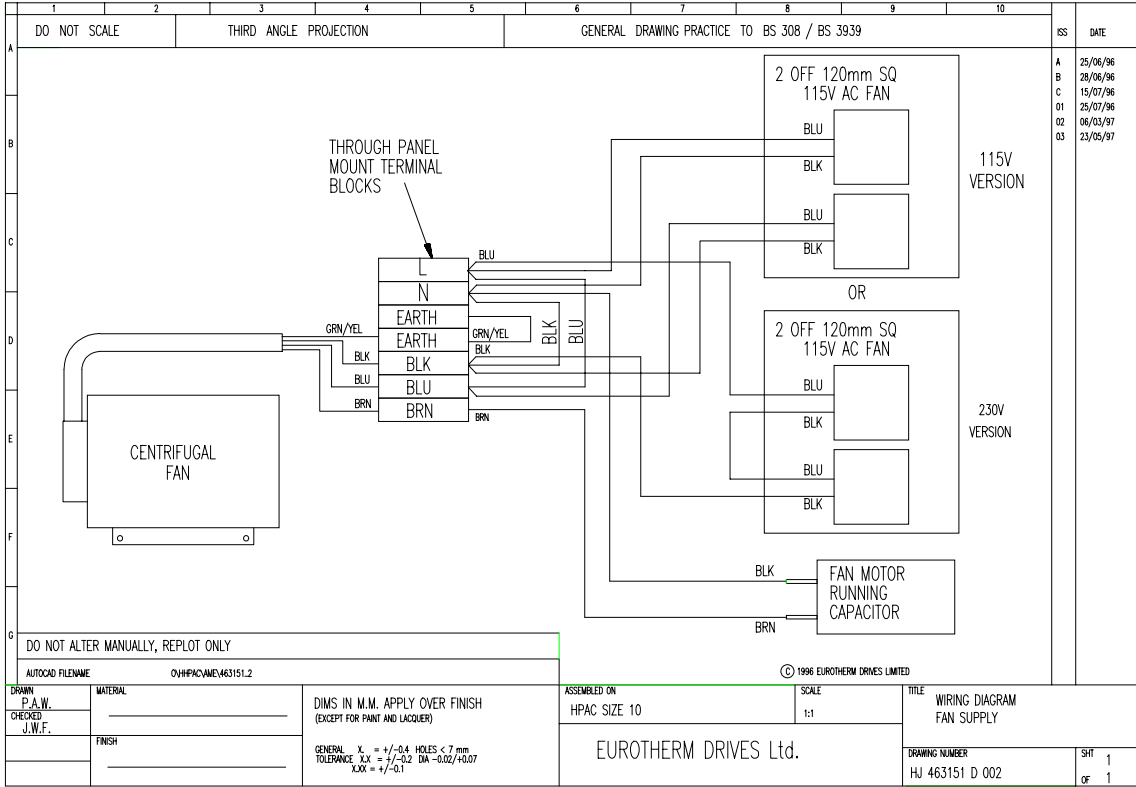
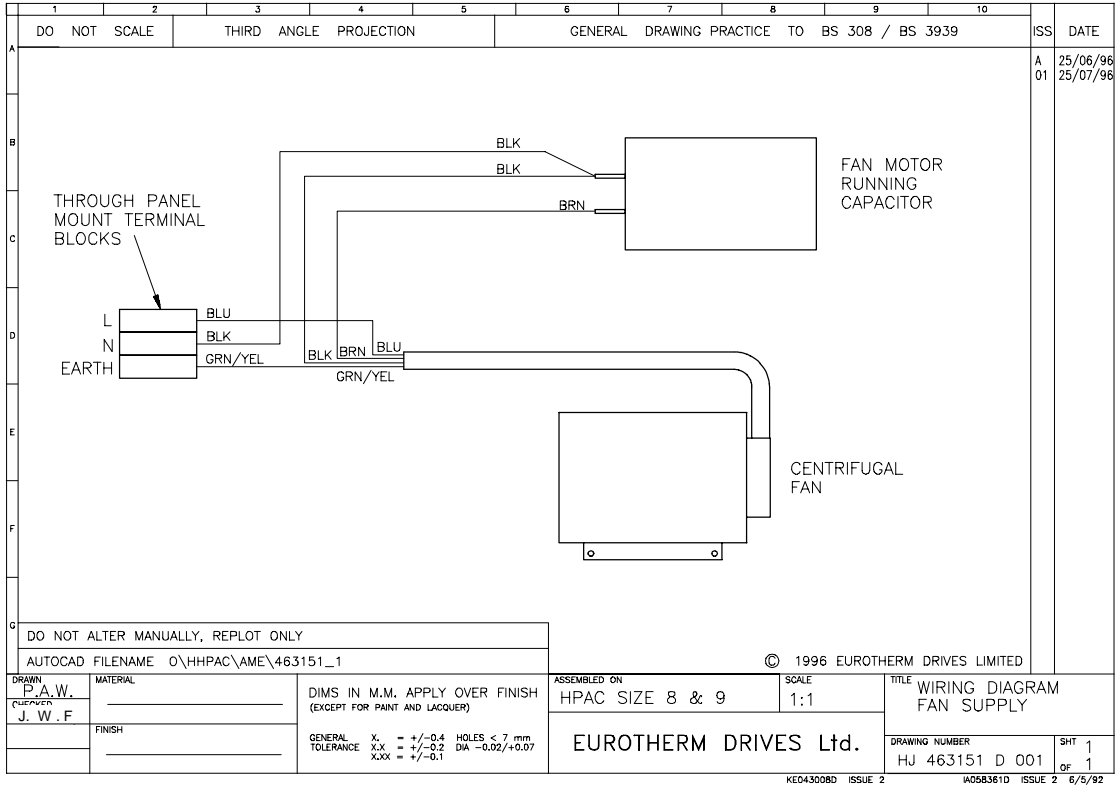

PHASE ASSEMBLY REPLACEMENT

The inverter power stage consists of 3 identical phase assemblies. Each phase assembly consists of heatsink, IGBT module, 1/3 of the input bridge, DC link capacitors and PCB 'AH389193'. It is intended that the whole phase assembly be carried as a spare part and replaced as a unit. Spare phase assemblies are available for each of the three drive frame sizes. The spare phase assembly comes with a 'service tray' which is designed to assist in phase assembly replacement. It also protects the other delicate components within the drive during the replacement procedure.

Observe all electrical warnings and static handling precautions at the front of this section - 'Component Replacement'.

Supplied Parts

- Service plate.
- M5 x 10 lg. hex. head. screws (2 off)
- Heatsink clamps (4 off) - used to retain phase assembly in packaging. They are to be reused in the replacement assembly if the original clamps are excessively distorted.
- Insulating caps - 3 off

Required Tools

- Drive ratchet wrench, 300mm extension, 8mm & 10mm socket.
- Drive No.3 Posidrive bit.

Phase Assembly Removal Procedure

Refer to Figure 9.4 - 'Power Component Identification' at the end of this section.

1. Remove drive top and bottom terminal cover (plastic) via 2 off $\frac{1}{4}$ turn fasteners at top and bottom of drive.
2. Disconnect 30-way op-station ribbon cable from power control PCB CON 10 (see figure 9.1).
3. Remove drive front cover (metal) which is attached via 4 off $\frac{1}{4}$ turn fasteners (take care not to damage PCBs beneath cover).
4. Remove DC+ and DC- bus bars at the top of the drive. - remove 2 M6 captive nuts at the capacitor joining plate assembly and 2 M6 captive nuts at the external connection busbars. (300 mm long extension recommend for this step).
5. Remove capacitor joining plate assembly via M6 captive washer nuts. Note that the nuts on the left hand side of the M2 phase are covered with plastic insulating caps. **These caps are a safety requirement and must be fitted.**
6. If removing the M3 phase limb from an inverter which has a Brake unit fitted, it will be necessary to remove the brake connecting plate. (Refer to Chapter 8).
7. Remove 2 M6 captive nuts from input busbar on phase limb to be replaced. (300 mm long extension recommended for this step).
8. Remove 2 M6 hex bolts and washers from output busbar on phase limb to be replaced (300mm long extension recommended for this step).
9. Disconnect cable(s) from printed circuit board on phase limb to be replaced. Take note of PCB connectivity.
10. Disconnect earth wire on phase limb to be replaced by removing 1 off M4 captive nut at chassis.
11. Insert service plate underneath phase limb to be removed. Secure to side panels of drive using 2 off M5x12 screws.
12. Loosen heatsink clamps (4 per phase assembly) and rotate through 90°.
13. Carefully remove phase limb assembly.

Phase Assembly Replacement Procedure

1. Replace any badly distorted heatsink clamps with spare clamps provided. (Clamps used in packaging).
2. Carefully slide replacement phase limb assembly into position making sure that the studs on the input busbars (left-hand side) located in the holes provided on the phase limb busbar. Re-fit nuts and washers, but do not tighten.
3. Re-fit output busbar bolts and washers and tighten to 6.8 NM torque.
4. Secure phase limb assembly to chassis using heatsink clamps.
5. Remove service plate.
6. Tighten input busbar nuts to 6.8 NM torque.
7. Secure earth wire to chassis - 4NM torque.
8. Reconnect cable(s) to phase limb assembly printed circuit board.
9. Refit capacitor joining plate with M6 captive nuts to 6.8 NM torque.
10. Refit insulating caps to M2 (middle) left-hand side capacitor joining plate nuts.
11. Refit DC busbars 2 off M6 captive nuts on capacitor joining plate tightened to 6.8 NM torque and 2 off M6 captive nuts at the external connection busbars tightened to 6.8 NM torque.
12. Refit brake connection plate and top cover if required (refer to Chapter 8)
13. Refit drive front cover (metal) via 4 off $\frac{3}{4}$ turn fasteners (take care not to damage PCBs beneath cover).
14. Reconnect 30-way op-station ribbon cable to power control PCB CON 10 (see figure 9 .1).
15. Refit drive top and bottom terminal cover (plastic) via 2 off $\frac{3}{4}$ turn fasteners at top and bottom of drive.

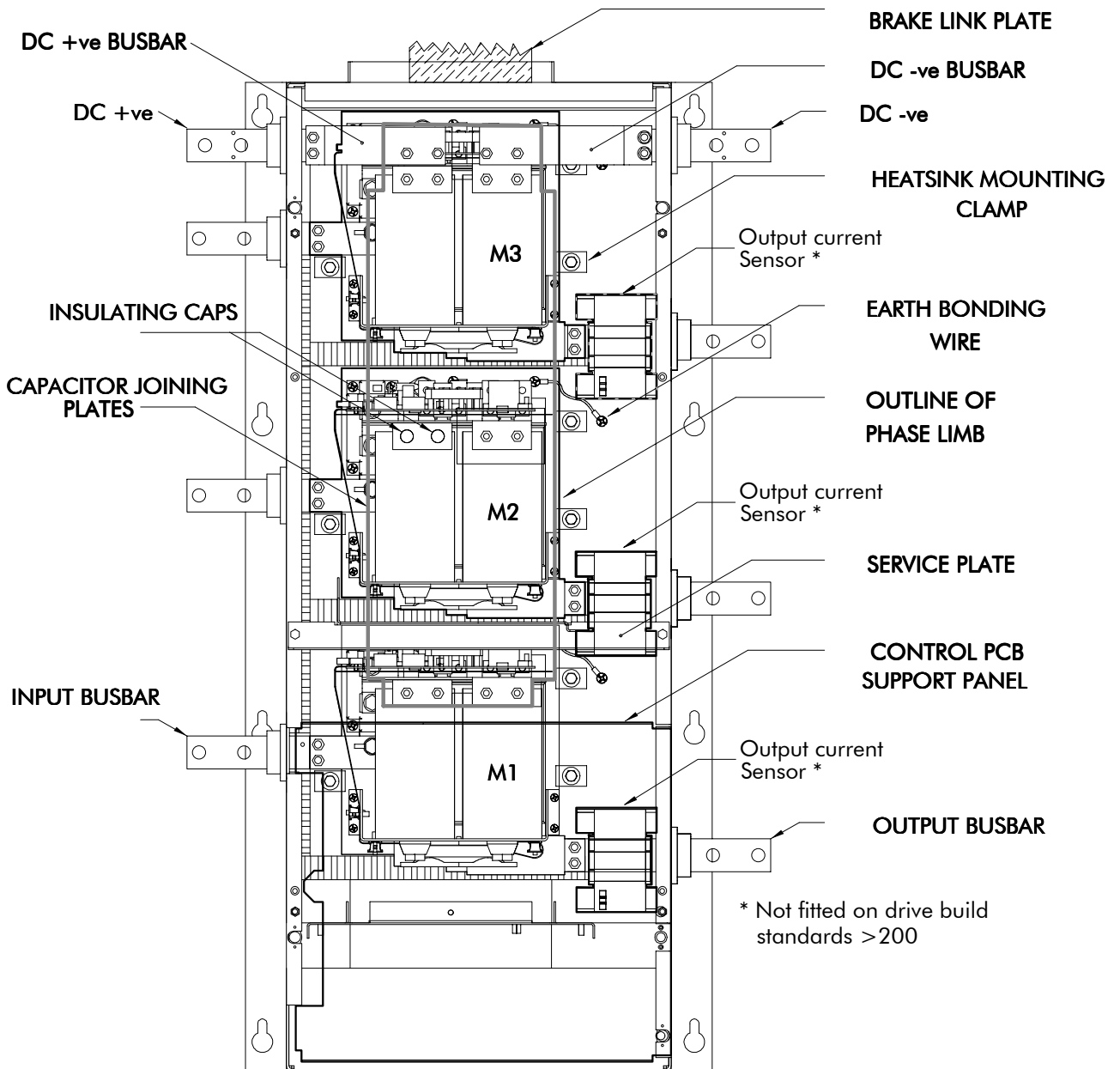
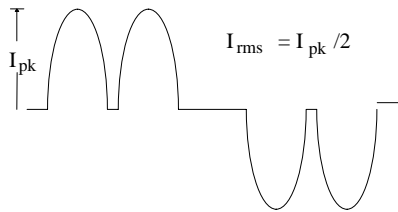

Figure 9.4 Power Component Identification (type 8)

Appendix A

1. Connections required suitable for busbars.
2. Foot mounting.
3. The typical current waveform is shown below:



4. Harmonic current content. Total rms current comprises:

Fundamental	95.0%
5th Harmonic	33.0%
7th Harmonic	10.0%
9th Harmonic	0.5%
11th Harmonic	5.0%
5. 3 phase line choke for use with an inverter.
6. Rated RMS value of current, I_{rms} , will be quoted.
7. Overload capability 150% of I_{rms} for 60 seconds.
8. Choke should not saturate at I_{pk} corresponding to 2 times rated RMS current - the inductance shall be maintained within -25% under this condition.
9. To be suitable for 50°C ambient and connection to terminals at 70°C.
10. To be suitable for vertical or horizontal mounting.
11. To be suitable for continuous connection to 480V ±10% 3 phase supply [earth (TN) or non-earth(IT) references].
12. To be suitable for 50 or 60Hz operation.
13. Packaging: suitable for delivery to Eurotherm Drives' Goods In Department without any damage.
14. Unit to display rating label which will include Eurotherm Drives part number to be approved by Eurotherm Drives Ltd.
15. Design should be rated to IP00 (optional IP20)
16. Input and output connections to be labelled L1, L2, L3.
17. Suitable earth connection to be provided.
18. Earth terminal to be identified by international ground symbol (IEC417 Symbol 5019).
19. Weight to be advised (kg).
20. Heat output to be minimised and advised to Eurotherm Drives (Watts).
21. Any plastic used to be flame retardant (V0 minimum).
22. Winding-to-winding and winding-to-earth must withstand 3kV AC test voltage for 1 minute, to be applied to each choke.
23. Insulation resistance between winding and core at no less than 500V DC to be greater than 100MΩ.
24. Design must be CE marked to conform to the Low Voltage Directive by using BS EN 60289 (1995). The supplier should maintain design evidence for a period of 5 years from the last shipment. Design parameters: Pollution Degree 2, Overvoltage Category III.
25. Design also to be in accordance with UL 506, to allow future UL and C-UL marking by supplier.
26. This specification to be read in conjunction with the mechanical drawing: CO 389936 D 201/202/203.

© 1996 EUROTHERM DRIVES LIMITED

File Name: G:\MSDOCS2\463---\463115.WRD				
ISS:	DATE	DRN:	RB	DRAWING NUMBER: HL463115C
3	190398	CHKD:	MP	TITLE: Rating Specification for HPAC AC line choke
				

Issue D 20.02.1995 GA387648C017

Extract from CO389936D201, 202, 203 Issue 2 Type 8, 9 & 10 Choke Outline Drawing

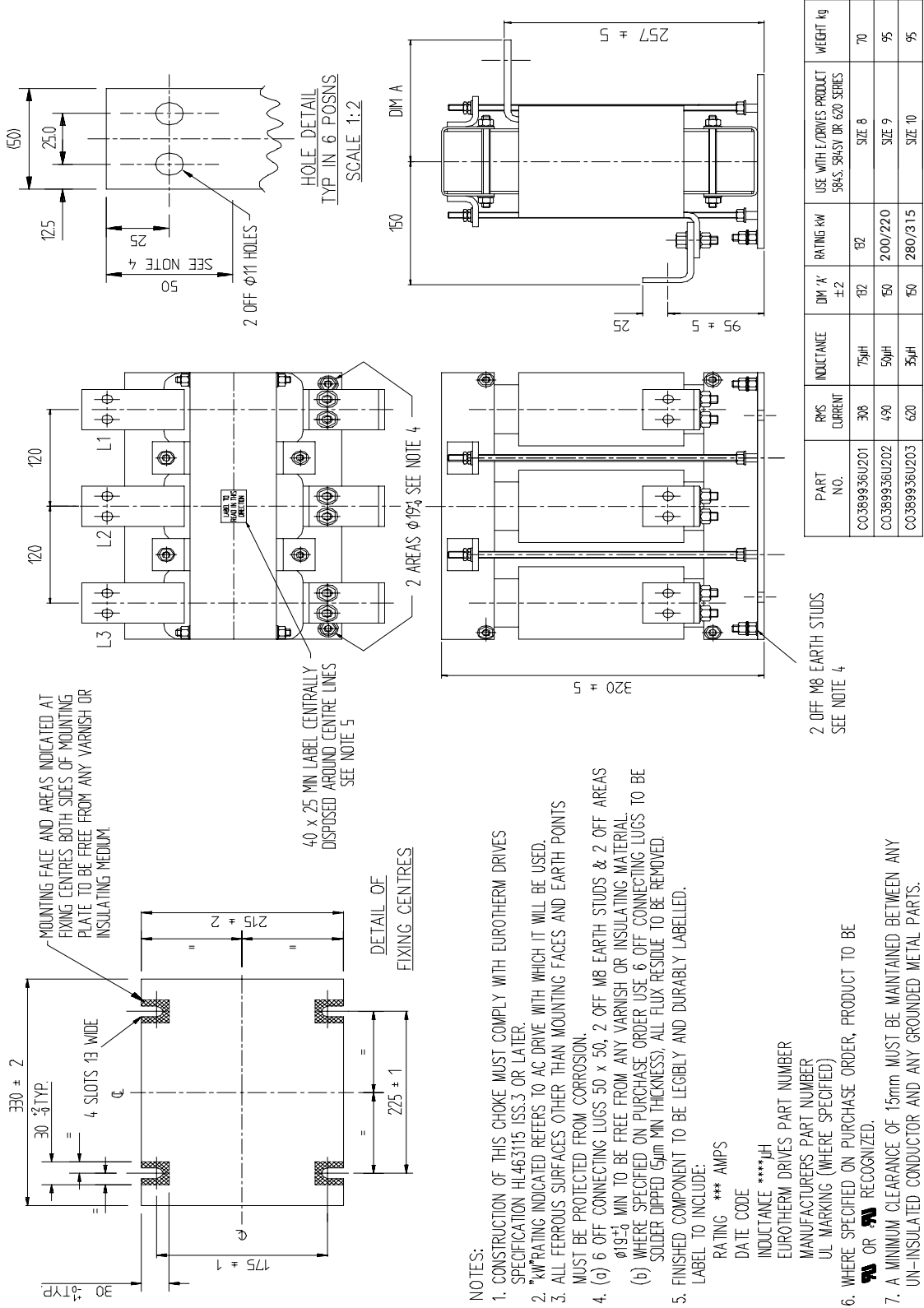

- NOTES:
- CONSTRUCTION OF THIS CHOKE MUST COMPLY WITH EUROTHERM DRIVES SPECIFICATION HL463115 ISS.3 OR LATER.
 - "kW" RATING INDICATED REFERS TO AC DRIVE WITH WHICH IT WILL BE USED.
 - ALL FERROUS SURFACES OTHER THAN MOUNTING FACES AND EARTH POINTS MUST BE PROTECTED FROM CORROSION.
 - (a) 6 OFF CONNECTING LUGS 50×50 , 2 OFF M8 EARTH STUDS & 2 OFF AREAS $\phi 19 \pm 1$ MIN TO BE FREE FROM ANY VARNISH OR INSULATING MATERIAL.
(b) WHERE SPECIFIED ON PURCHASE ORDER USE 6 OFF CONNECTING LUGS TO BE SOLDER DIPPED (50µm MIN THICKNESS), ALL FLUX RESIDUE TO BE REMOVED.
 - FINISHED COMPONENT TO BE LEGIBLY AND DURABLY LABELLED.
LABEL TO INCLUDE:
RATING *** AMPS
DATE CODE
INDUCTANCE ****µH
EUROTHERM DRIVES PART NUMBER
MANUFACTURERS PART NUMBER
UL MARKING (WHERE SPECIFIED)
 - WHERE SPECIFIED ON PURCHASE ORDER, PRODUCT TO BE OR RECOGNIZED.
 - A MINIMUM CLEARANCE OF 15mm MUST BE MAINTAINED BETWEEN ANY UN-INSULATED CONDUCTOR AND ANY GROUNDED METAL PARTS.

Appendix B EMC and Filter Installation

This appendix provides specific additional EMC and filter installation guidelines for the 584S/620 type 8, 9 and 10 inverters. Refer to base product manual for more EMC information.

EMC FILTERS TO REDUCE LINE CONDUCTED NOISE

The 584S/620 type 8, 9 and 10 industrial drives can be supplied with filters to meet the 'industrial' Class A conducted emission limits of EN55011 when used with 300m of screened motor cable and the specified 3% minimum AC line choke as listed below:-

Table B.1 AC Supply Filter and Line Choke Part Numbers for Conformance with EN55011 Class A.

584S/620		584S Rating	620 Rating	No. of CO464517 Filters Required in Parallel *	Total Filter Watt Loss	AC Line Choke
Type 8	0900/400	CT + HVAC	CT	One	50W	CO389936U201
Type 8	1100/400	CT + HVAC	CT	One	50W	CO389936U201
Type 8	1320/400	CT + HVAC	CT	One	50W	CO389936U201
Type 9	1600/400	CT + HVAC	CT	Two	100W	CO389936U202
Type 9	1800/400	CT + HVAC	CT	Two	100W	CO389936U202
Type 9	2000/400	CT + HVAC	CT	Two	100W	CO389936U202
Type 9	2200/400	CT + HVAC	CT	Two	100W	CO389936U202
Type 10	2500/400	CT + HVAC	CT	Two	100W	CO389936U203
Type 10	2800/400	CT + HVAC	CT	Two	100W	CO389936U203
Type 10	3150/400	CT + HVAC	CT	Two	100W	CO389936U203

CT = Constant Torque

HVAC = Quadratic Torque

* Safe for use on earth referenced (TN) and non earth referenced (IT) supplies. See warnings in this section.

Mounting arrangements are shown in figures B.2 and B.4 and wiring arrangements in figures B.3 and B.5.

Figure B.1 - AC Supply Filter CO464517D

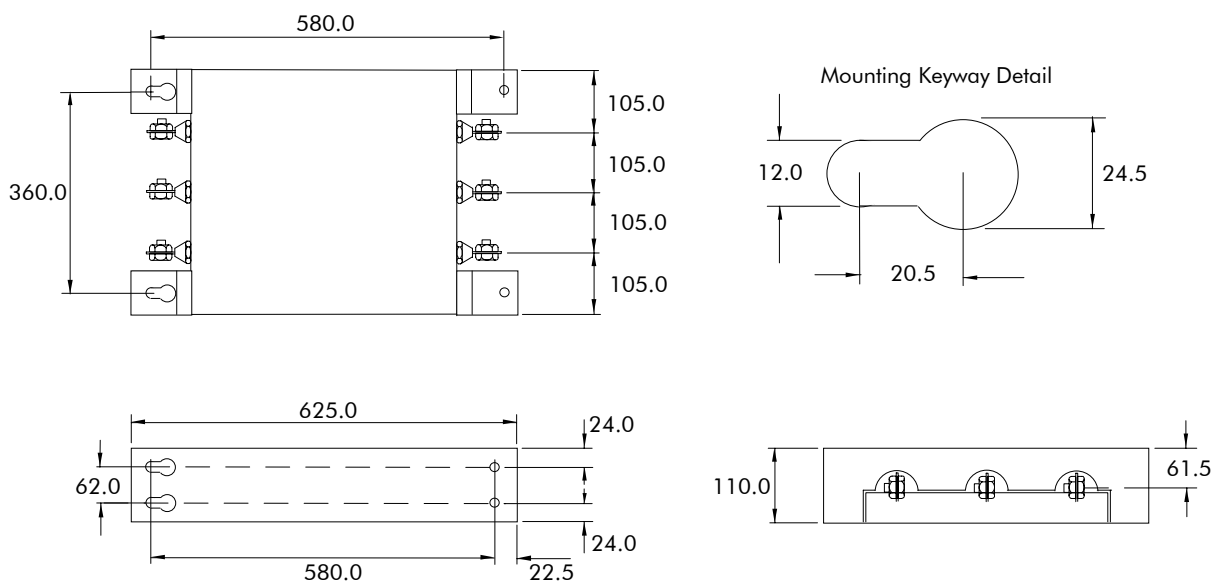

Dimensions are in millimetres

Figure B-2 Filter Mounting Details Using 1 off Part No. CO464517 for Type 8

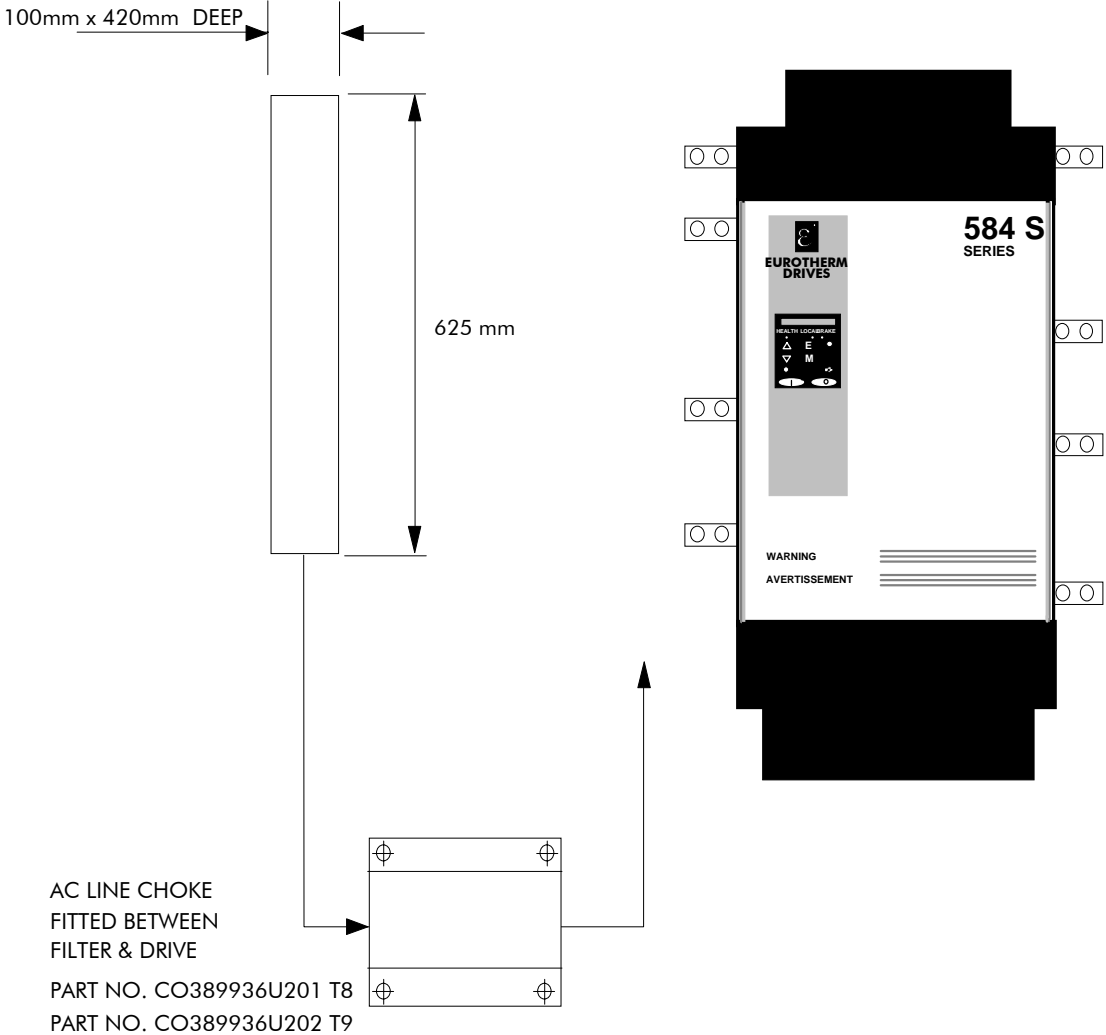

Figure B-3 Wiring Details Using 1 off Part No. CO464517 for Type 8

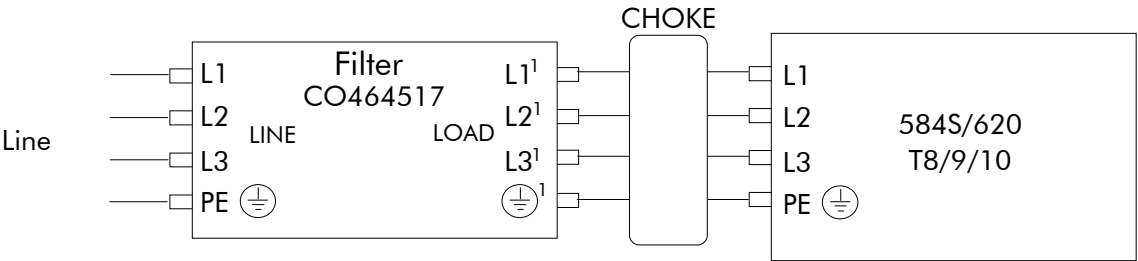

Figure B-4 Filter Mounting Details using 2 off Part No. CO464517 Type 9 and Type 10

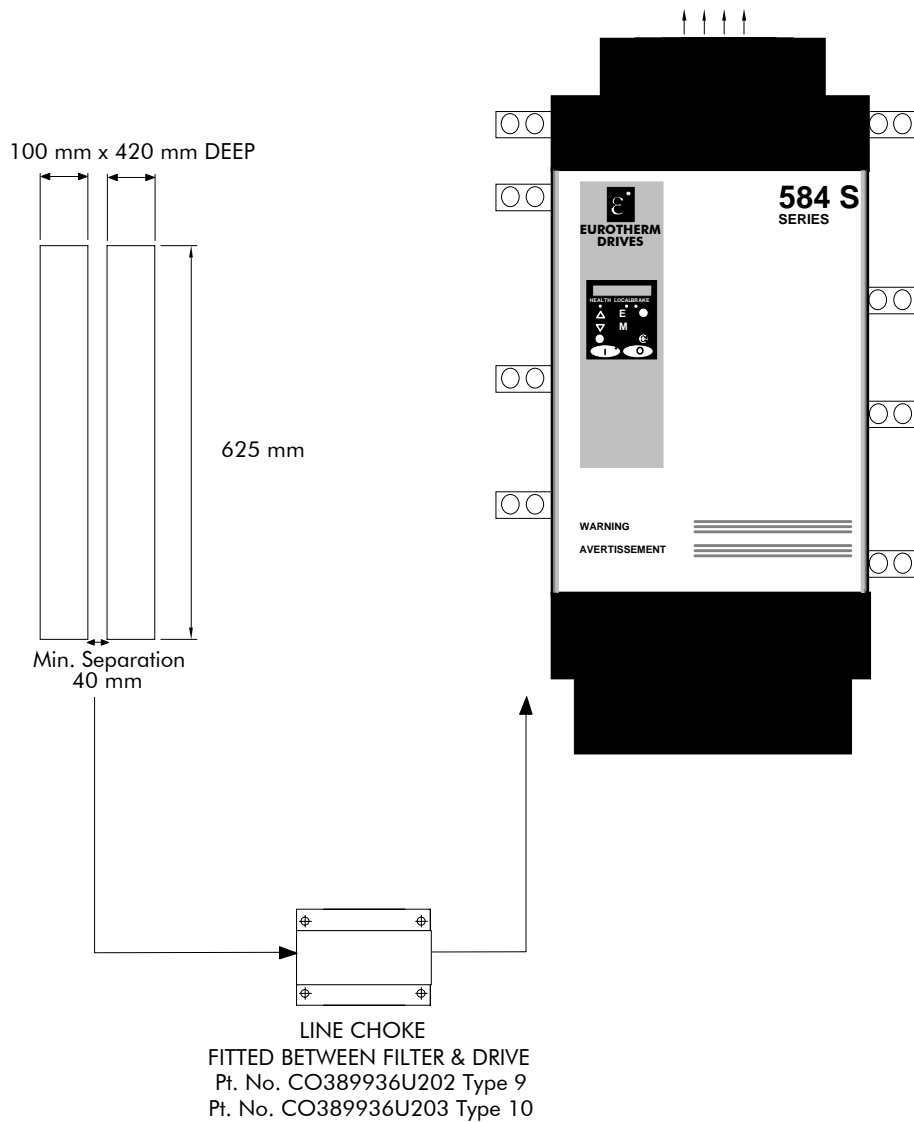
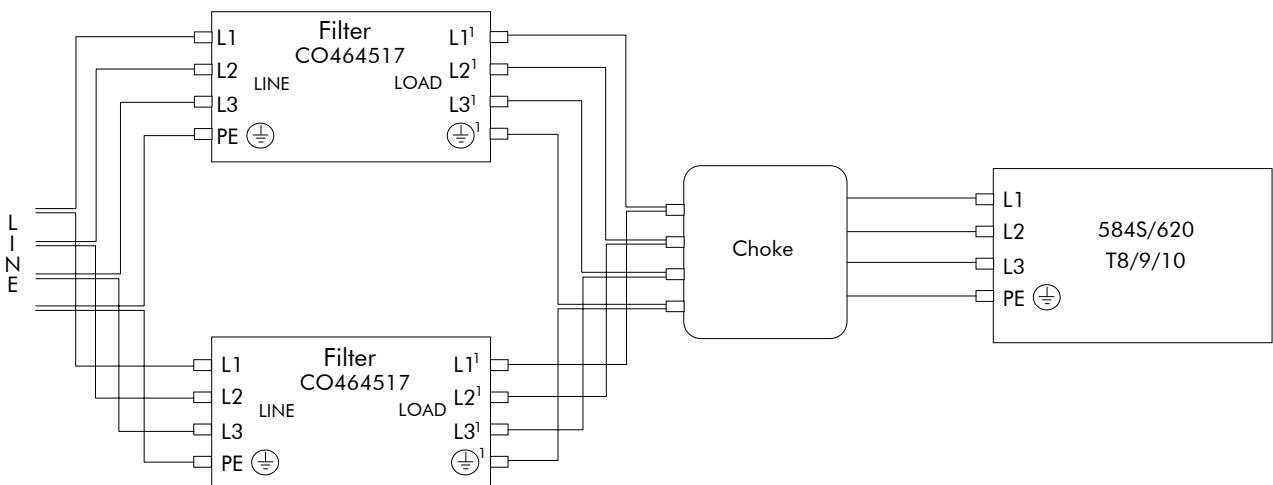

Figure B-5 Using 2 off Part No. CO464517 Type 9 (2200) and Type 10



NOTE: For 584S/620 type 8, 9 and 10 the specified EMC line choke in table B-1 must still be fitted between the 584S/620 and its filter. This is to ensure reliability of both filter and drive.

The EMC filter and line choke should be mounted as close to the drive module as possible. Take care not to obstruct the filter or drive ventilation ducts. 40 mm spacing between filters should be allowed. The connections between the drive, choke and filter must always be as short as possible, and be segregated from all other cables. If this cable/busbar exceeds 1.0m in length then it must be replaced with a screened/armoured cable, with the screen/armour earthed at both the filter, choke and inverter ends with large-area contact surfaces, preferably with metal cable glands. The routing of the connections between the filter, choke and drive module should be chosen to ensure their close proximity, but the filter flying leads should **NEVER BE BUNCHED TOGETHER. Failure to achieve this will result in increased conducted emissions.** The filter flying leads may reach 100°C under normal operating conditions and should be separated by at least one cable diameter and adequately ventilated. The connection between the drive module and the motor must be installed away from all other cables or wires. Ideally the filter(s) and choke will be mounted onto the same metallic back panel as the drive. The RF connection between the drive, filter, choke and panel should be enhanced as follows:-

- Remove any paint/insulation between the mounting points of the EMC filter(s), choke, drive module and panel.
- Liberally apply petroleum jelly over the mounting points and securing threads to prevent corrosion. Alternately conducting paint could be used on mounting panels.
- If the proceeding is not possible, then the RF earth bond between the filter and drive module is usefully improved by making an additional RF earth connection using wire braid of at least 10mm² cross sectional area (due to skin effect).

NOTE: Metal surfaces such as eloxized or yellow chromed (e.g., cable mounting or 35mm DIN rails, screws and bolts) have a high RF impedance which can be very detrimental to EMC performance.

A low RF impedance path must be provided between the motor frame and back panel on which the drive, choke and EMC filters are mounted. This low impedance RF path should follow the path of the motor cables in order to minimise the loop area. **Failure to do so will result in increased conducted emissions.**

This will normally be achieved by:-

1. Bonding the armour of the motor supply cables at one end to the motor frame and at the other to the cubicle back panel. Ideally 360° bonding is required, which can be achieved with cable glands.
2. Ensuring that conduit containing the motor supply cables is bonded together using braid. The conduit shall also be bonded to the motor frame and the cubicle back panel

Refer to base product manual for more detailed information.

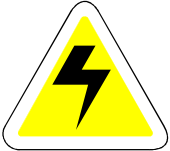
	<p>The filter flying leads may reach 100°C under normal operating conditions. Leads should be separated by at least one cable diameter and adequately ventilated. NEVER BUNCH LEADS TOGETHER.</p> <p>The recommended EMC filters are designed to work with supplies which are balanced with respect to earth (i.e. earthed referenced supplies). On some specific customer sites the supply may not be balanced with respect to earth. The recommended standard EMC filters are not recommended be used on such supplies. Refer to Eurotherm Drives for more information.</p> <p>The EMC filters contains large capacitors phase-to-phase and phase-to-earth. Discharge resistors are fitted, but the filters, terminals and wiring must not be touched for a period of 5 minutes after the removal of the AC supply. Not adhering to this warning can result in electric shock.</p> <p>The EMC filter must only be used with a permanent earth connection due to the high earth leakage</p>
---	---

SPECIFICATION OF ACHIEVABLE EMC EMISSIONS

584S/620 type 8, 9 and 10 drive modules with the option to be 'CE' marked meet the following EMC emission limits, provided they are installed with the specified EMC filters, and line chokes as shown in table B1 and in accordance with the EMC installation instructions.

Port	Phenomenon	Basic standard	Level	Generic standard
Enclosure Port	radiated	EN55011 (1991)	Class A (cubicle mount)	EN50081-1 (1992)
AC Power Port	conducted (with specified filter)	EN55011 (1991)	Class A	EN50081-2 (1994)
AC Power Port	conducted (no filter)	EN55011 (1991)	130dBµV @ 150kHz* (common mode) 130dBµV @ 150kHz* (differential mode) Reducing with frequency by 20dB/decade	

* 3kHz switching frequency, 300 metres screened motor cable.

For immunity specification, refer to base manual.

Appendix C Declarations

For more information, refer to the base product manual.

584S/620 (TYPE 8, 9 & 10) DECLARATION OF CONFORMITY FOR EMC



EC DECLARATION OF CONFORMITY

In accordance with the EEC Directive 89/336/EEC,
Article 10 and Annex 1, (EMC DIRECTIVE)

We Eurotherm Drives Ltd, address as below, declare under our sole responsibility that the following electronic products

584S/620 Std/Link/Com (Type 8, 9 & 10)

when installed and used in accordance with the instructions in the product manual (provided with each piece of equipment) and using the specified EMC filters to which this declaration refers is in conformity with the following standards:-

BS EN50081-2 (1994),

BSEN50082-1# (1992) & draft prEN50082-2** (1992)

Following provisions of EEC-Directive
89/336/EEC with amendments 92/31/EEC and 93/68/EEC

.....
Dr Martin Payn,
Conformance Officer
Eurotherm Drives Ltd

.....
Dr Dan Slattery,
Technical Director
Eurotherm Drives Ltd

8th April 1999

.....
Date

Compliant with these immunity standards without specified EMC filters.

* For information only.

EUROTHERM DRIVES LIMITED

NEW COURTWICK LANE, LITTLEHAMPTON, WEST SUSSEX BN17 7RZ

TELEPHONE: 01903 737000 FAX: 01903 737100

Registered number: 1159876 England. Registered Office: Southdownview Way, Worthing, West Sussex BN14 8NN

© 1999 EUROTHERM DRIVES LIMITED

File Name: P:\PRODUCTS\CE\EMC\PRODUCTS\584S8_10\PRODFILE\HK389937.912

ISS:	DATE	DRN: NS	DRAWING NUMBER:	HK389937C912
C	08.04.99	CHKD: MP	TITLE:	SHT 1 OF 1 SHTS
			584S/620 Std/Link/Com (Type 8, 9 & 10) EC Declaration of Conformity for EMC	

Issue D 20.02.1995 GA387648C017

584S/620 (TYPE 8, 9 & 10) MANUFACTURERS EMC DECLARATION**MANUFACTURERS EMC DECLARATION**

In accordance with the EEC Directive 89/336/EEC,

Article 10 and Annex 1, (EMC DIRECTIVE)

We Eurotherm Drives Ltd, address as below, declare under our sole responsibility that the following electronic products

584S/620 Std/link/Com (Type 8, 9 & 10)

when installed and used in accordance with the instructions in the product manual (provided with each piece of equipment) and using the specified EMC filters to which this declaration refers is in conformity with the following standards:-

BS EN50081-2(1994),

BSEN50082-1# (1992) & draft prEN50082-2#* (1992)

Following provisions of EEC-Directive

89/336/EEC with amendments 92/31/EEC and 93/68/EEC

.....
Dr Martin Payn,
Conformance Officer
Eurotherm Drives Ltd

.....
Dr Dan Slattery,
Technical Director
Eurotherm Drives Ltd

8th April 1999

.....
Date

Compliant with these immunity standards without specified EMC filters.

* For information only.

EUROTHERM DRIVES LIMITED

NEW COURTWICK LANE, LITTLEHAMPTON, WEST SUSSEX BN17 7RZ

TELEPHONE: 01903 737000 FAX: 01903 737100

Registered number: 1159876 England. Registered Office: Southdownview Way, Worthing, West Sussex BN14 8NN

© 1999 EUROTHERM DRIVES LIMITED

File Name: : P:\PRODUCTS\CE\EMC\PRODUCTS\584S8_10\PRODFILE\HK389937.914				
ISS:	DATE	DRN: NS	DRAWING NUMBER: HK389937C914	
C	08.04.99	CHKD: MP	TITLE:	
			Manufacturers EMC Declaration	
			SHT 1 OF 1 SHTS	

Issue D 20.02.1995 GA387648C017

584S/620 (T8, 9 & 10) EC DECLARATION OF CONFORMITY FOR ELECTRICAL SAFETY



EC DECLARATION OF CONFORMITY

In accordance with the EEC Directive 73/23/EEC and amended by 93/68/EEC,

Article 13 and Annex III, (LOW VOLTAGE DIRECTIVE)

We Eurotherm Drives Limited, address as below, declare under our sole responsibility that the following Electronic Products

584S and 620 Std/Link/Com (Type 8/9/10)

When installed and operated with reference to the instructions in the Product Manual (provided with each piece of equipment), is in accordance with the following standard:-

VDE0160(1994)/EN50178(1998)

Following provisions of EEC-Directive
73/23/EEC with amendment 93/68/EEC

8th April 1999

.....
Dr Martin Payn,
Conformance Officer
Eurotherm Drives Ltd

.....
Dr Dan Slattery,
Technical Director
Eurotherm Drives Ltd

.....
Date

EUROTHERM DRIVES LIMITED

NEW COURTWICK LANE, LITTLEHAMPTON, WEST SUSSEX BN17 7RZ

TELEPHONE: 01903 737000 FAX: 01903 737100

Registered number: 1159876 England. Registered Office: Southdownview Way, Worthing, West Sussex BN14 8NN

© 1999 EUROTHERM DRIVES LIMITED

File Name: P:\PRODUCTSCE\SAFETYPRODUCTS\584S8_10\LVD\PRODFILE\HK389955.955				
ISS:	DATE	DRN: MP	DRAWING NUMBER: HK389955C955	
D	08.04.99	CHKD: DS	TITLE: EC Declaration of Conformity for Electrical Safety	SHT 1 OF 1 SHTS

Issue D 20.02.1995 GA387648C017

584S/620 (T8, 9 & 10) MACHINERY DIRECTIVE**MANUFACTURER'S DECLARATION**

The following Electronic Products

584S and 620 Std/Link/Com (Type 8/9/10)

are components to be incorporated into machinery and may not be operated alone.

The complete machinery or installation using this equipment may only be put into service when the safety considerations of the Directive 89/392/EEC are fully adhered to.

Particular reference should be made to EN60204-1 (Safety of Machinery - Electrical Equipment of Machines).
All instructions, warnings and safety information of the Product Manual must be adhered to.

A handwritten signature in black ink, appearing to read 'M. Payn'.

.....
Dr Martin Payn,
Conformance Officer
Eurotherm Drives Ltd

A handwritten signature in black ink, appearing to read 'D. Slattery'.

.....
Dr Dan Slattery,
Technical Director
Eurotherm Drives Ltd

8th April 1999

.....
Date

EUROTHERM DRIVES LIMITED

NEW COURTWICK LANE, LITTLEHAMPTON, WEST SUSSEX BN17 7RZ

TELEPHONE: 01903 737000 FAX: 01903 737100

Registered number: 1159876 England. Registered Office: Southdownview Way, Worthing, West Sussex BN14 8NN

© 1999 EUROTHERM DRIVES LIMITED

File Name: P:\HPAC\DOCS\MANUAL\ISSUE_8\APPEND_C.WRD				
ISS:	DATE	DRN: MPC	DRAWING NUMBER: HK389955C918	
C	08.04.99	CHKD: MP	TITLE: Machinery Directive	SHT 1 OF 1 SHTS

Issue D 20.02.1995 GA387648C017

Supply Harmonic Analysis

Assumptions: 90-280kW: 18,000A short circuit supply capability, constant torque load and stated nominal motor output power. * 315kW: 30,000A short circuit supply capability.

$$THD(V) \times 100 = \frac{\sqrt{\sum_{h=2}^{h=40} O_{h^2}}}{O_{1n}} \%$$

where O_{1n} is the rated rms value of the fundamental voltage of the supply transformer.

The results conform to stage 3 of the Engineering Recommendation G.5/3 September 1976, Classification 'C': Limits for Harmonics in the UK Electricity Industry.

Drive Type	584S/620									
Type	8	8	8	9	9	9	9	10	10	10
Motor Power (kW)	90	110	132	160	180	200	220	250	280	315 *
Fundamental Voltage (V)	400	400	400	400	400	400	400	400	400	400
Harmonic No.	RMS Current (A)									
Typical Motor Efficiency	93%	93%	93%	94%	94%	94%	94%	95%	95%	95%
1	141.3	172.1	209.2	246.8	274.2	325.1	350.6	360.9	416.9	442.2
5	67.2	74.9	80.0	99.5	102.9	114.8	112.7	130.0	141.8	151.9
7	32.3	32.4	29.3	39.1	36.9	37.8	26.3	44.1	44.5	34.2
11	10.4	12.3	14.8	17.5	19.3	22.0	20.1	24.9	27.4	26.9
13	6.5	6.8	7.2	8.9	9.3	10.8	10.1	12.1	13.7	11.5
17	4.7	5.5	6.2	7.6	8.1	8.9	7.4	10.2	10.7	10.4
19	2.8	3.2	3.9	4.6	5.2	6.1	5.9	6.9	7.8	7.2
23	2.6	2.9	3.1	3.9	4.0	4.2	3.2	4.9	4.9	4.5
25	1.7	2.1	2.5	2.9	3.3	3.8	3.2	4.3	4.6	4.4
29	1.6	1.7	1.7	2.2	2.2	2.3	2.0	2.7	2.8	2.5
31	1.1	1.4	1.6	2.0	2.1	2.3	1.7	2.7	2.7	2.5
35	1.0	1.1	1.0	1.3	1.4	1.6	1.5	1.8	2.0	1.8
37	0.8	1.0	1.0	1.3	1.3	1.4	1.2	1.7	1.7	1.5
Total RMS Current (A) *	160.5	191.5	227.0	271.0	297.0	348.0	370.1	387.5	444.0	469.9
THD (V) %	2.6	2.9	3.1	3.9	3.9	4.3	4.44	4.7	4.9	3.23

* These are different to that stated in the table [Electrical Ratings -Power circuit (Chapter 2)] due to different assumed operating conditions.

© 1997 EUROTHERM DRIVES LIMITED

ISS:	DATE	DRN: NS	DRAWING NUMBER: HP463431C970
A	19/1/98	CHKD:	TITLE:
B	8/04/99	 EUROTHERM DRIVES	584S/620 Harmonic analysis

Issue D 20.02.1995 GA387648C017

ISS.	MODIFICATION	ECN No.	DATE	DRAWN	CHK'D
5	Page 2-5 removed "Standard Fault Current Ratings", Tables 2.5 and 2.6, and "High Fault Current Ratings". Re-numbered tables 2.7 and 2.8 accordingly.	12188	14.11.97	FEP	SG
6	Pages 1-1, 2-4 replaced HA463076 with HA463584. Page 1-1 added 620 COM. Page 3-1 removed from Block 4 Third digit options 2 to 6 and following Note. Pages B-1, 2, 3 Replaced filter CO389456 with CO464517. Page 4-1 Corrected Internal supply fail LEDs from 2 and 1 to 8 and 7. Replaced filter diagrams CO389936D001-3 and CO389936D101-3 with CO389936D201-3 and references throughout the manual. Page B-4 changed 50 to 300 metres screened motor cable. Modifications to HL463115C.	12628			
		12360			
		12605			
		12559			
		12594	30.03.98	FEP	MPC
7	Added to page 6-1 under Warning 'This unit must be ... outlet duct.' Removed torque setting 11.5Nm (8.5 ft-lb) from page 8-2. Page 2-6 corrected torque setting 6.6 lb-ft to 71.5 lb-ft and 3.8 lb-ft to 40.5 lb-ft. Page C-3 replaced 'prEN50178(1995)' with 'EN 50178 (1997)' and re-worded sentence 'When installed ... standard:-'	12941	6.10.98	FEP	SG
		12923			
		13106			
		13114			
8	Table 1-1 Rating changed from 200kW to 220kW, 280kW to 315kW and 300Hp to 350Hp. Page 1-6 added 350Hp option to table. Table 2.1, 2.2, B.1 and page C-5 New ratings added. Page 2-5 replaced AH389166 with 'see Chapter 9'. Page 3-1 Block 2 added new ratings. Block 4 Third digit changed IP20 to IP2X added (terminals::IP00). Figures 8-2 and 8-3 replaced. Page 9-2 added build standards <200 and >200 columes. Page 9-4 removed AH389167 and AH389444. Figure 9.2 added AH464472U101 diagram. Figure 9-11 added '*Ouput current sensors not fitted on drive build standards >200'. Appendix C - Certificates updated to reflect change of registered office, telephone and fax numbers. C-5 - Added new ratings to Harmonic Analysis.	12033	19.03.99	FEP	NB
FIRST USED ON		MODIFICATION RECORD			
		584S/620 Manual Addendum			
 EUROTHERM DRIVES		DRAWING NUMBER			SHT. 2
		ZZ463284			OF 2

